



# **DRAINAGE SYSTEMS**

## **TECHNICAL DOSSIER**

[ulmaarchitectural.com](http://ulmaarchitectural.com)



DRAINAGE AND ARCHITECTURE



<b>01</b>	<b>INTRODUCTION</b>	<b>6-15</b>
	Who we are	6
	Our material	8
	What sets us apart	11
	Solution adapted to your project	14

<b>02</b>	<b>PRODUCT RANGE</b>	<b>16-153</b>
	<b>Domestic Drainage</b> .....	<b>18</b>
	<b>Self</b>	20
	· Pedestrian use and sporadic car traffic	
	· Low hydraulic requirements	
	· Channel width 100-150-200-250-300	
	· No profile / galvanised profile / stainless steel profile	
	<b>Mini</b>	36
	· Pedestrian use and sporadic car traffic with height limitation	
	· Low hydraulic requirements	
	· Channel width 100-150-200-300	
	· No profile / galvanised profile / stainless steel profile	
	<b>Urban</b>	48
	· Pedestrian use and sporadic car traffic	
	· All types of hydraulic requirements	
	· Channel width 100-150-200-250-300	
	· No profile / galvanised profile / stainless steel profile	
	· Option of preslope 0.5%.	
	· Option of cascaded slope	
	<b>Sport</b>	62
	· Sports and recreation facilities	
	· Channel widths: 100-200	
	<b>Hydro</b>	72
	· Plastic channels	
	· Pedestrian use and sporadic car traffic	
	· Low hydraulic requirements	
	· Channel widths: 100-200	
	<b>Technical drainage</b> .....	<b>82</b>
	<b>MultiV+</b>	84
	· Intermediate loads and road traffic	
	· Low and medium hydraulic requirements	
	· Optimised V-shaped section with self-cleaning effect	
	· Rapidlock® locking system	
	· 8 locking points per ml	
	· Channel widths: 100-150-200	
	· Option of preslope 0.5%.	
	· Option of cascaded slope	

# INDEX

**Civil drainage** ..... 100

**Civil - S** ..... 102

- High loads with height limitation
- Low hydraulic requirements
- Channel width 150-200-250-300
- Locking system Bolted at 8 points per ml

**Civil - F** ..... 114

- High loads
- All types of hydraulic requirements
- Channel width 100-150-200-250-300-400
- Locking system Bolted at 8 points per ml

**KompaqDrain®** ..... 136

- Monolithic channel
- Specially designed for heavy traffic
- For all hydraulic requirements
- MAXFLOW system, which increases water speed
- Channel width 100-150-200
- Option of different surfaces depending on application

**Slotted Gratings** ..... 154

- Hidden drainage grating solution
- Applicable to almost the entire range of channels
- All types of hydraulic requirements
- Channel widths 100-150-200-250-300
- Various slot heights and widths

**Other Solutions** ..... 162

**03 INSTALLATION INSTRUCTIONS** ..... 168-195

**Installation details** ..... 173

- Self family ..... 173
- Mini family ..... 176
- Urban family ..... 177
- Sport family ..... 180
- Hydro family ..... 182
- MultiV+ family ..... 186
- Civil - S family ..... 189
- Civil - F family ..... 190
- KompaqDrain® family ..... 192
- Unique details ..... 195

**04 CONDITIONS OF SALE** ..... 196

## + Who we are

We have been experts in designing, manufacturing and installing high-performance prefabricated polymer concrete since 1990.

With a qualified personable team, technological training, and the know-how acquired over many years of experience, we now offer drainage solutions for a globalized world.

We target two market segments:  
**Drainage and Architecture.**



D R A I N A G E   A N D   A R C H I T E C T U R E

*- for people by people -*



Our certificates



## + Solutions for Architecture

For our architecture segment, we offer three comprehensive solutions for both new builds and refurbishments.

- **VENTILATED FACADES**
- **ARCHITECTURAL PRECAST**



# Our group

**ULMA Architectural Solutions** is part of **ULMA Group**, one of the Basque Country's leading industrial groups, which, in turn, is part of **MONDRAGON**, the largest cooperative group in the world.

It currently has a significant network of subsidiaries in countries on all five continents. In 2019 we directly employed more than 5200 people, with turnover reaching over 900 million euros.

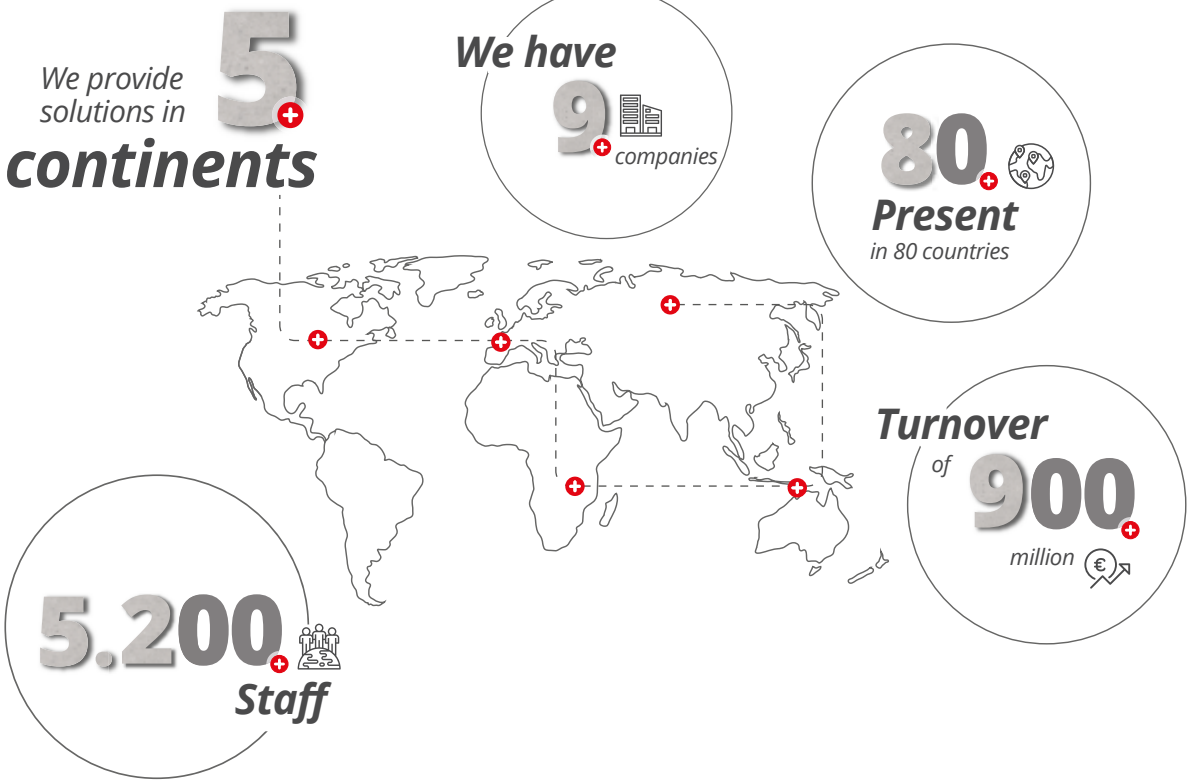

# + Our material

**Polymer Concrete** is a high quality material composed of a select combination of silica and quartz aggregates.

## It is ideal for the evacuation of fluids

The polymeric nature of this material allows smooth surfaces with very low friction on prefabricated elements, thereby facilitating the rapid run-off of fluids and also offering a water absorption index which is virtually non-existent, compared with 5-10% with traditional concrete.

### COMPRESSIVE STRENGTH

Applied to prefabricated systems, it can support up to 1300 kp/cm<sup>2</sup> compared to the 700 kp/cm<sup>2</sup> supported by fibre cement or 500 kp/cm<sup>2</sup> supported by traditional concrete. **Before breaking or cracking!**

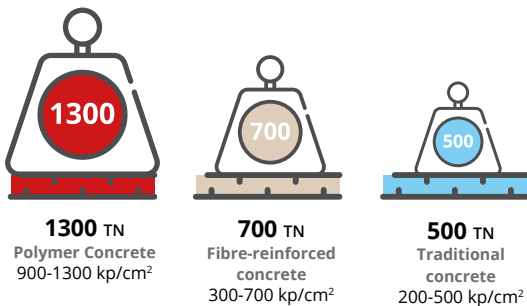

### ABRASION RESISTANCE

The hardness of the silica aggregates guarantees good conservation of surfaces exposed to road traffic. **Optimal abrasion resistance!**

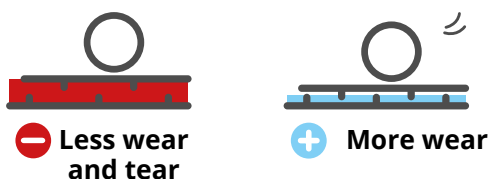

# RESISTANCE

- POLYMER CONCRETE
- FIBRE-REINFORCED CONCRETE
- TRADITIONAL CONCRETE

### RESISTANCE TO CHEMICALS

One of the most resistant materials to any chemical product. Its components do not react to contact and prevent disintegration and deformation. **Proven!**



### FLEXURAL STRENGTH

Applied to prefabricated systems, it can support up to 18-25 MPa compared to the 15-20 supported by fibre cement or the 1-5 MPa supported by traditional concrete. **Before breaking or cracking!**

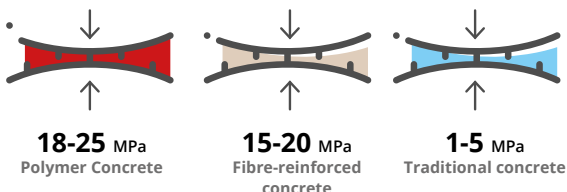

### SHOCK RESISTANCE

As it is a composite material, it guarantees the perfect conservation of surfaces against usage or the passing of time. **No perception of wear!**

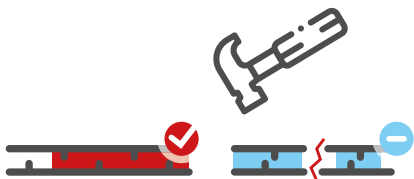

### ZERO WATER ABSORPTION

It has practically 0% water absorption and guarantees the sealing of the pieces. **Impermeable!**

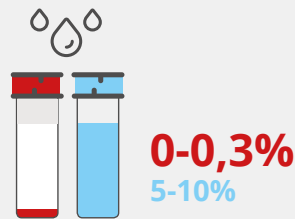

### UNALTERABLE IN FREEZE/THAW CYCLES

On the contrary to traditional materials it is not affected by freeze-thaw cycles and prevents the appearance of fissures or cracks.

**It maintains all properties intact!**

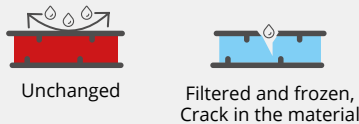

### LIGHTWEIGHT

Thanks to its excellent mechanical properties, it allows pieces with a finer profile and smaller dimensions to be made.

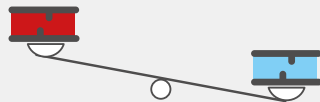



# **We offer the best drainage system**

*We are committed to **sustainable water management.***

The importance of a good drainage system lies not only in the need for rapid discharge of surface water, but also in doing so in a rational manner, with lower peak flows and adequate quality.

Today, when rationalisation of resources is becoming increasingly important in society and in environmental policies, ULMA is committed to working alongside developers and designers to ensure sustainable urban drainage systems in town planning.



## **WHY LINEAR DRAINAGE**

Our duct and drainage system is based on **LINEAR DRAINAGE**, which offers many advantages over point drainage.

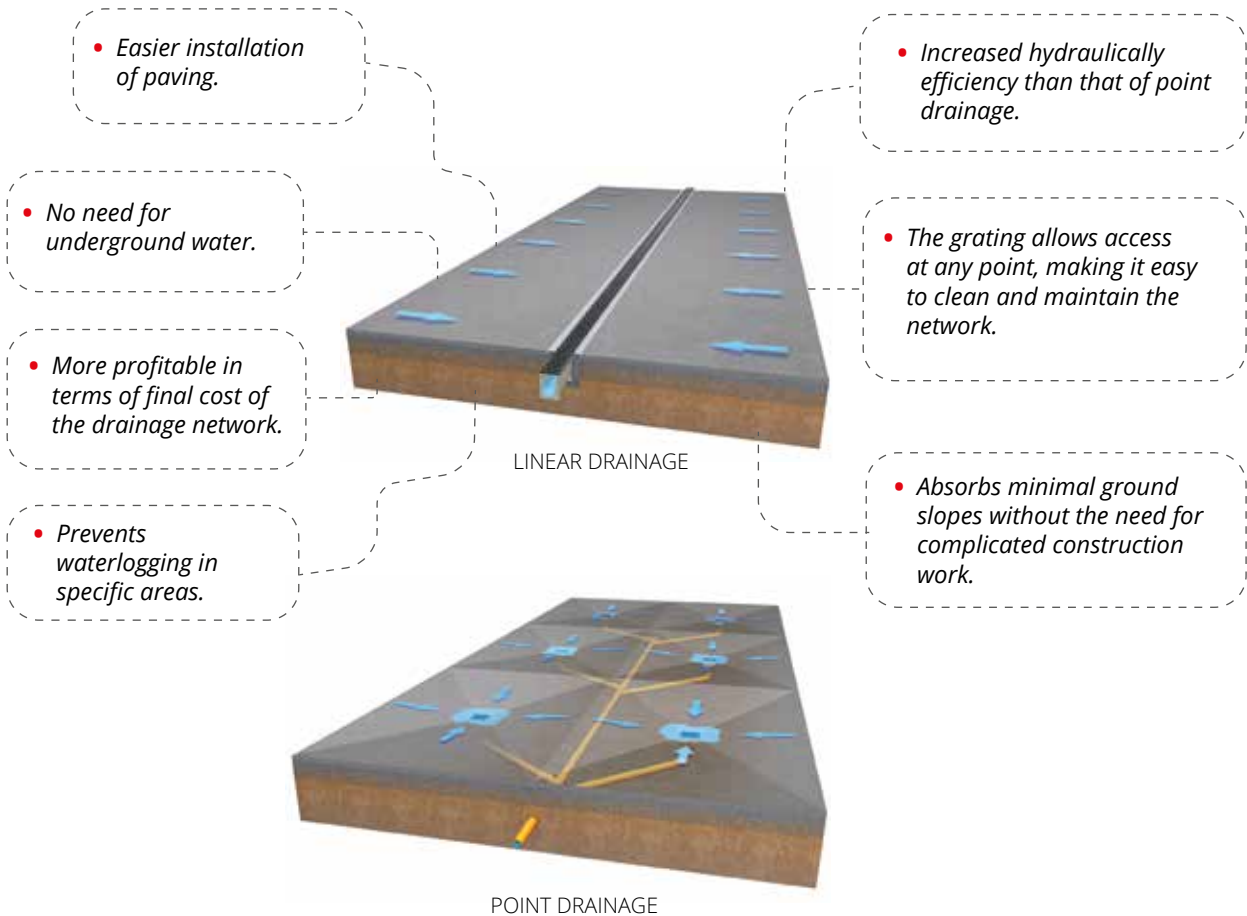

# + What sets us apart

## THE BENEFITS OF POLYMER CONCRETE IN DRAINAGE CHANNELS

*Polymer concrete manufactured by ULMA is an excellent material for surface drainage channels.*

Apart from its outstanding properties in terms of strength, the resins that make up polymer concrete provide an extremely smooth surface compared to traditional concrete. This gives the channels up to 30% more hydraulic capacity, bringing a reduction in hydraulic section. This fact, combined with narrower sections thanks to the material's strength characteristics, ensures more optimised channels.

In addition to the proven quality of the material, this reduction in the size of the channels brings a series of benefits in terms of installation, particularly with regard to cost and time savings.

**HIGHER  
MECHANICAL  
STRENGTH**



**GREATER  
HYDRAULIC  
CAPABILITY**



**MORE  
OPTIMISED  
CHANNELS**

- Quicker installation.
- Lighter.
- No need for special machinery.

- Narrower gratings.
- Aesthetics.

- Cheaper transport and storage.
- Cost savings.

- Room for other parallel facilities, kerbs...
- Less digging.
- Less volume of concrete needed.

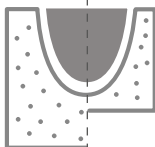

**+30% Q**  
ULMA



# Our complete drainage system

We offer **complete drainage system** with all the required products, from water collection up to the point of discharge, with a range of channels that adapt to the requirements of each project, manufactured in accordance with Standard UNE EN-1433.

- CHANNELS
- SUMP UNITS
- GRATINGS
- LOCKING SYSTEM
- BUCKET
- LATERAL OUTLETS
- END CAPS

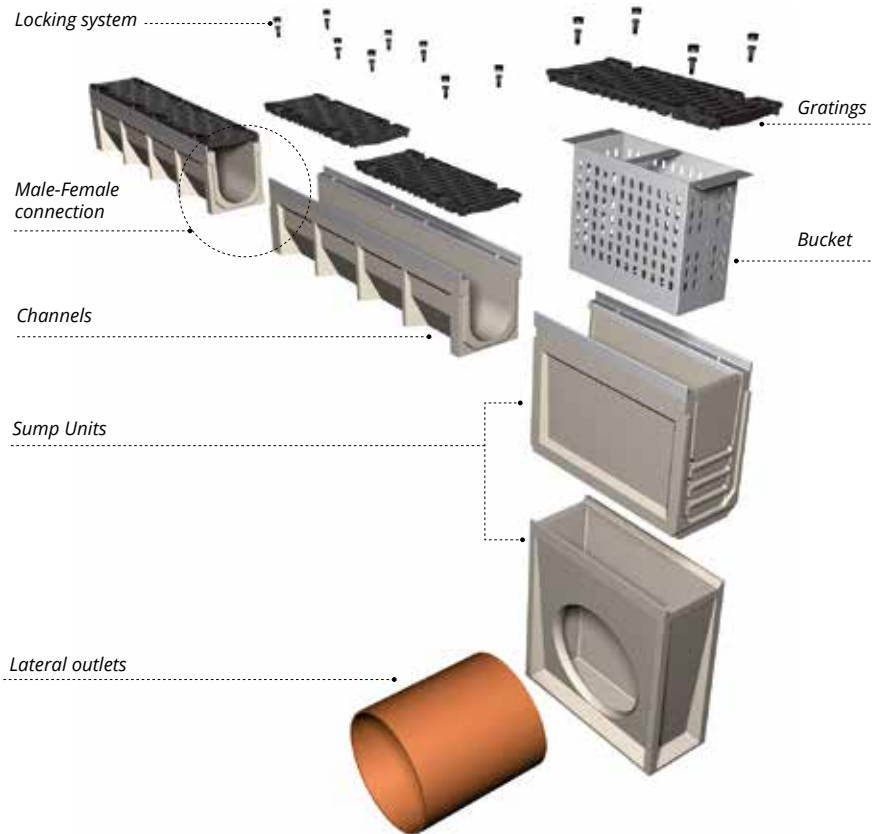

## • SLOPE CONFIGURATIONS

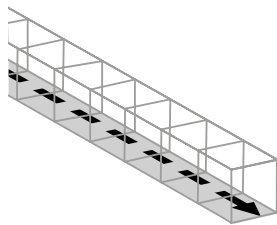

### WITHOUT SLOPE

All of the channels are placed at the same height.

**Advantages:** Very simple from an execution point of view. It has a hydraulic capacity sufficient for short stretches of drainage.

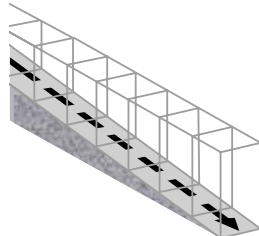

### PRESLOPED

Channels of variable height with a built-in slope of 0.5% and 2.5%, according to the model.

**Advantages:** Very appropriate for areas where the ground has no natural slope.

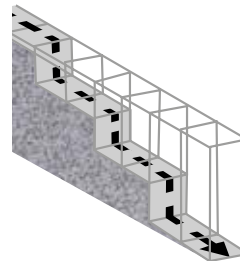

### CASCADE SLOPE

A combination of straight channels of various heights that are joined using step connectors.

**Advantages:** Simple and economic onsite execution when slopes need to be included.

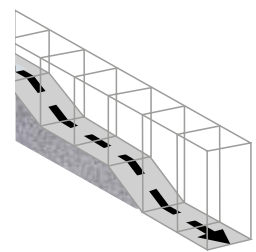

### MIXED SLOPE

A combination of the previous systems.

**Advantages:** Very appropriate to drain long-length stretches. It allows for the optimization of hydraulic capacity to the utmost.



# We are focused on customers' needs

We offer a complete range of gratings in various materials and designs.

In addition to gratings for pedestrian and vehicle use, we have a wide range of gratings for heavy-duty areas such as ports, docks and airports. All our gratings are designed according to the European Standard EN-1433 which regulates covering and sealing devices for use in pedestrian and vehicle circulation areas, classifying the gratings in six categories, in accordance with the place of installation.



## GALVANISED & STAINLESS



Slotted



Length Slotted



Mesh



Perforated

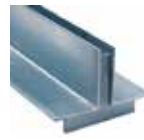

Single slot

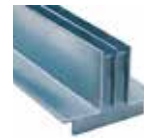

Double slot



Side slot

## COMPOSITE



Slotted



Mesh



Length Slotted

## DUCTILE IRON



Slotted



Length Slotted



Solid

## DUCTILE IRON STAINLESS



Slotted



Slotted

## LOCKING SYSTEMS

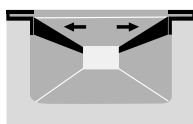

### CLICK LOCKING SYSTEM WITHOUT SCREW

- Especially for channels with no galvanized edge, nor cast iron edges.
- Specific for A15 load classes.
- No screws.

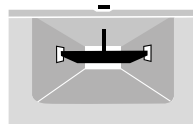

### LOCKING BAR AND SCREW

- Channels with and without edge-on.
- Up to load class C250.
- Two locking bars and two screws per LM

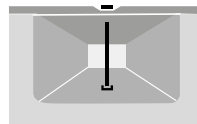

### SCREW TO THE CHANNEL BASE

- Channels with or without edges.
- Up to load class C250.
- Two screws per LM.



### BOLTLESS LOCKING SYSTEM

- Channels with profile
- Up to load class D400
- 8 fixing points per LM

**rapidlock**

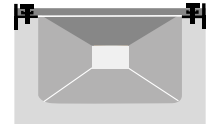

### 8 BOLTS PER GRATING

- Channels with galvanized or cast iron edges.
- Load classes from D400 up to F900.
- 8 screws per LM.



# Solution adapted to your project

## 1. LOAD CLASSES

Suitable channels must be chosen for each type of application, based on load class, in order to ensure they meet the strength capacity requirement. At ULMA we have channels for all types of applications.



A15



B125



C250



D400



E600



F900

**STANDARD EN 1433**

The products set out in this Technical Dossier are designed under the premises of Standard EN 1433 "Drainage channels for vehicular and pedestrian areas. Classification, design and testing requirements, marking and evaluation of conformity".

## 2. HYDRAULICS

**ULMA Architectural Solutions**  
**Hydraulic Calculation software**



To ensure drainage systems with optimal evacuation capacity and cost, ULMA Architectural Solutions has developed a multi-platform software solution offering the possibility of performing a hydraulic study for each project and precisely defining the most suitable channel.

**SIMPLICITY**

It only requires a few project parameters, such as line lengths, catchment areas, slopes and run-off coefficients of each surface, to accurately reflect the current situation and the subsequent study.

**MULTIPLE FUNCTIONALITIES**

You can enter different rainfall data for any geographic area worldwide, calculate different channel lines in the same project and find the right channel among hundreds of references in ULMA's extensive catalogue, based on their Heights, Widths, Sections, Load Classes or other characteristics.

**PRECISION**

To calculate the water's behaviour in the channels a mathematical model is used that takes the Spatially Varied Flow with Increasing Flow for Open Channels as the base, which describes the water's behaviour more accurately than other commonly used models and formulas.

**DETAILED REPORT**

As a result we obtain a report with references and dimensions of the necessary channels, sheet of water, filling percentages, water flows and speeds in each of the project lines. All the necessary data for the validation of the drainage system.

**COST REDUCTION**

The software optimises the cost of channel lines by selecting the most appropriate channel for the application, the exact location of intermediate outlets or the exact distribution of channels in cascade slope.



The value shown as Qref in the product datasheets refers to the maximum flow rate for a length of 10 metres and 0% slope.

## 3. APPLICATION

Each area of application has its own requirements, and at ULMA we have a wide variety of products and materials to respond to each of them. Checking with the technical department is recommended in order to ensure a correct choice.

**ENVIRONMENTAL REQUIREMENTS**

Using channels with stainless steel profiles or ductile iron edges, along with gratings in the same material, is recommended for environments with high salinity, as well as places where chemicals are used.

**USE REQUIREMENTS**

We have a wide range of gratings to meet the requirements of different Standards.



# LET US ADVISE YOU

## Improve safety

With its many years of experience in the area of surface drainage, ULMA's technical department is at your disposal to accompany you throughout the entire project.

1



### SETTING-OUT THE DRAINAGE LINES

Send us your plans and we will help you design the best way to drain the surface of your project. We will also advise you on choosing the right kind of resistance for the channels and gratings depending on their use and location.

2



### CHOOSING THE MOST OPTIMAL CHANNEL AND GRATING

With our Optimal Drain hydraulic calculation, we will find the optimal channel with the lowest possible cost.

3



### COMPLETE DRAINAGE SYSTEM

We will advise you to ensure your drainage project is as complete as possible. We will develop the exploded view of the entire system to ensure no element or accessory is missing. Sump units, connectors, covers...

4



### DOCUMENTATION FOR THE PROJECT

We will provide you with all the necessary documentation for the project. Data sheets, plans, files, BIM, DOP, quality control certificates...

5



### ADVICE ON INSTALLATION ON SITE

After we send you the material, we will still be there. We will advise you on installing the channels, defining the necessary concrete reinforcement, in addition to being present on site if required.



> Domestic drainage

> Technical drainage

> Civil drainage

# Domestic drainage



## Self

Channels for pedestrian use and occasional car traffic, for areas with low hydraulic requirements. Using a channel with a built-in profile is recommended, especially when finished with concrete or asphalt paving and/or with frequent passage of vehicles.

### Applications

Secondary streets, squares, playgrounds, schools, parks, gardens, etc.

Load class up to C250 (according to model).

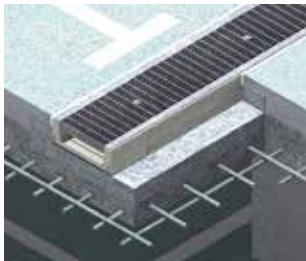

## Mini

Channels designed for areas with height limitation, pedestrian use and occasional traffic. Using a channel with a built-in profile is recommended, especially when finished with concrete or asphalt paving and/or with frequent passage of vehicles.

### Applications

Reinforced slabs, garage flooring structure, basements, showers, changing rooms, roofs, etc.

Load class up to C250 (according to model).



## Urban

Channels for pedestrian use and occasional car traffic, for all types of hydraulic requirements. Using a channel with a built-in profile is recommended, especially when finished with concrete or asphalt paving and/or with frequent passage of vehicles. Option of built-in slope, mixed slope or cascaded slope.

### Applications

Pedestrian areas, sports facilities, residential complexes, car parks for light vehicles, etc.

Load class up to C250 (according to model).



## Sport

Drainage channels for sports and recreation facilities.

### Applications

Football pitches, running tracks, showers, changing rooms, swimming pool paving, etc.

Load class up to C250 (according to model).



## Hydro

Polypropylene drainage channels for pedestrian use and occasional car traffic, for areas with low hydraulic requirements.

### Applications

Secondary streets, squares, playgrounds, schools, parks, gardens, etc.

Load class up to C250 (according to model).

# Technical drainage



## MultiV+

Channels with versatile uses suitable for intermediate loads and road traffic for areas with low and medium hydraulic requirements. Optimised V-shaped section with self-cleaning effect.

- Rapidlock® locking system
- Mechanical stability in 8 locking points
- Option of built-in slope, mixed slope or cascaded slope.

### Applications

**Pedestrian areas, commercial areas, and car parks for all types of vehicles.**

**Load class up to D400**

# Civil drainage



## Civil - S

Channels for large loads in areas with height limitations. Locking system with 8 bolts per linear metre.

### Applications

**Reinforced slabs, garage flooring structure, service stations, loading and unloading areas, industrial buildings, public roads, heavy vehicle car parks, etc.**

**Load classes up to F900**



## Civil - F

Drainage channels for large loads and all types of hydraulic requirements. Option of built-in slope, mixed slope or cascaded slope. Locking system with 8 bolts per linear metre.

### Applications

**Service stations, port loading and unloading areas, industrial buildings, airports, public roads, heavy vehicle car parks, etc.**

**Load classes up to F900**



## KompaqDrain®

Monolithic channel with built-in grating in a single body, for medium or high loads, specially designed for intense vehicle traffic. Useful for all types of hydraulic requirements.

Incorporates innovative MAXFLOW system, which increases water speed.

### Applications

**Motorways or dual carriageways, airports, service stations, and areas with heavy traffic.**

**Load classes up to F900**

## Slotted

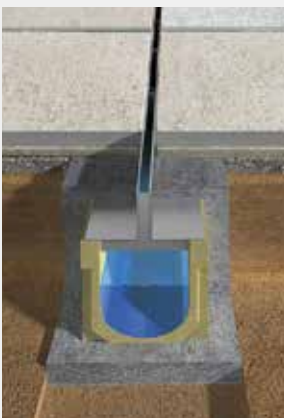

Hidden drainage grating solution, applicable to almost the entire range of channels, for all hydraulic requirements. In galvanised or stainless steel.

**Load classes up to D-400**

## Other solutions

### Cable ducts



### Trenches



### Industrial skirting



### Runways



...and more.





# DOMESTIC

## DRAINAGE

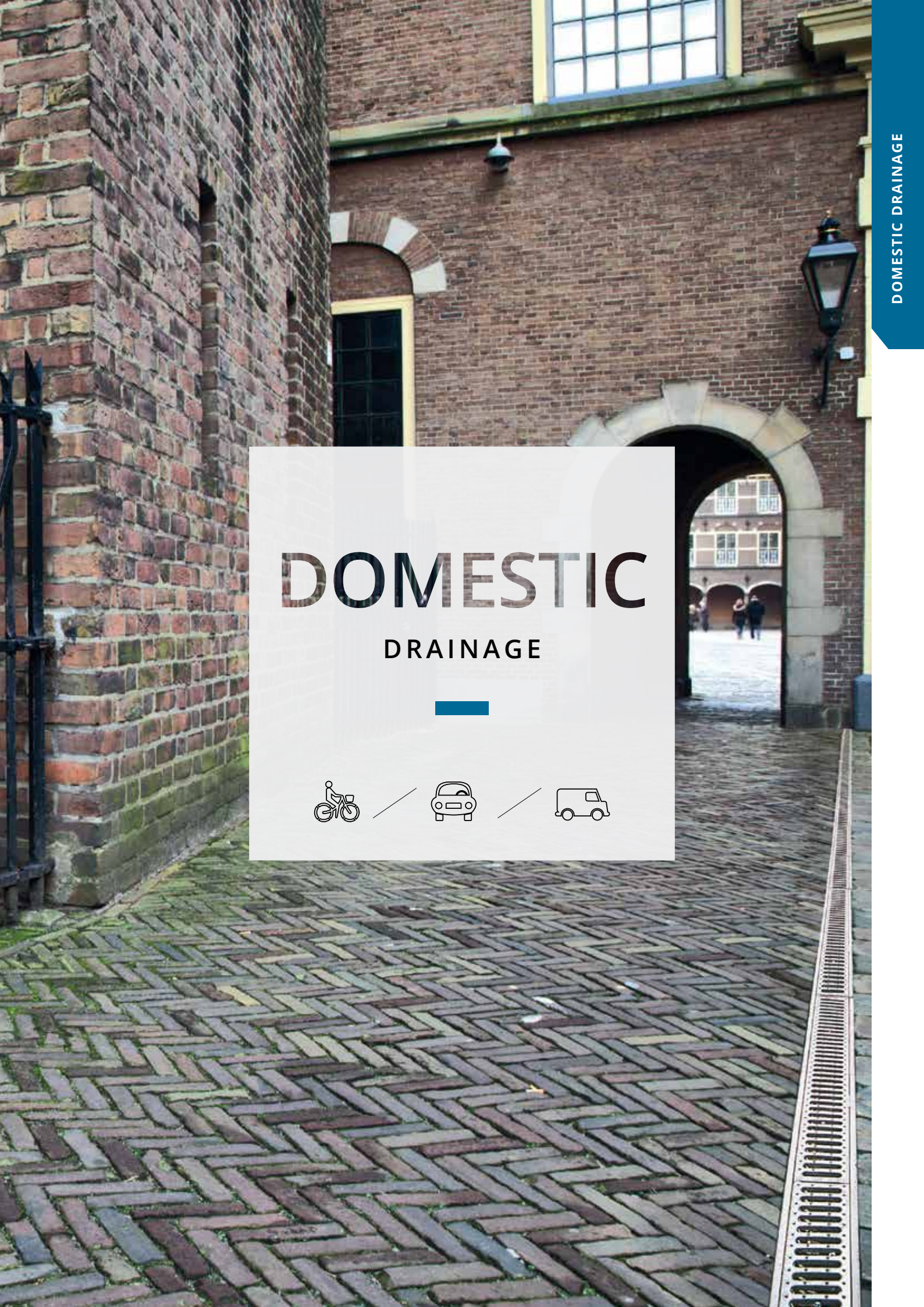



# SELF

## SYSTEM

**Interior streets, gardens, recreational areas, squares, parks...**

Multipurpose, constant height channels (without slope), very practical in short drain stretches or with frequent outlets.

Available with various grating locking systems (quick system, locking bars, with screws), all types of grating materials up to load class C250.

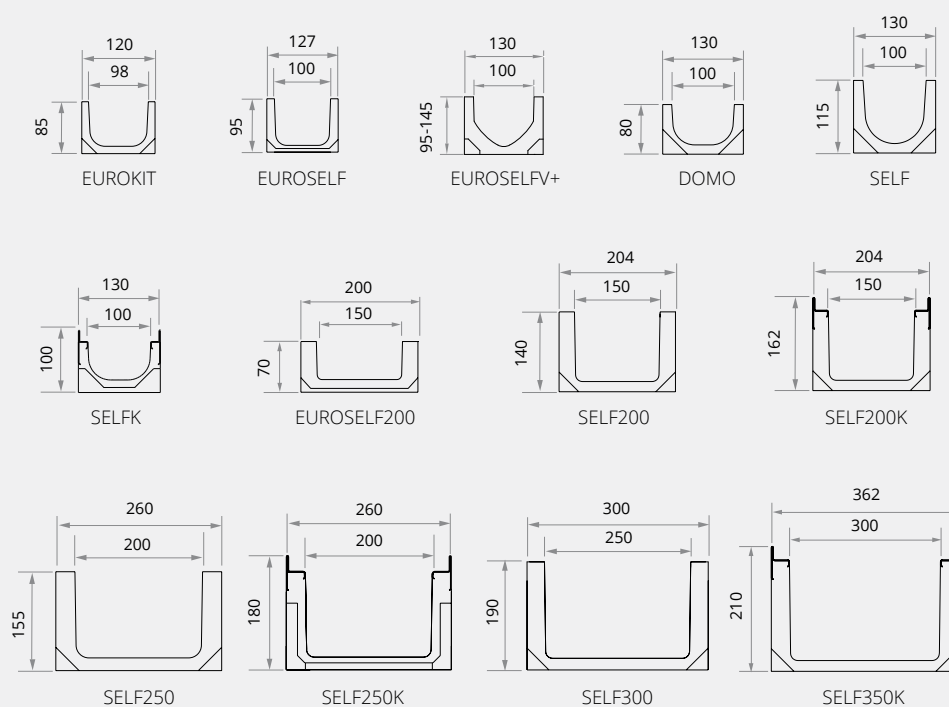

Load Class  
up to A15  
EN-1433 Standard

# EUROKIT



ULMA Linear Drainage Channel type EUROKIT: External width 120 mm; Internal width 98 mm and overall height 85 mm to collect rainwater in 1 metre long units. Locking system "click" type without screws.

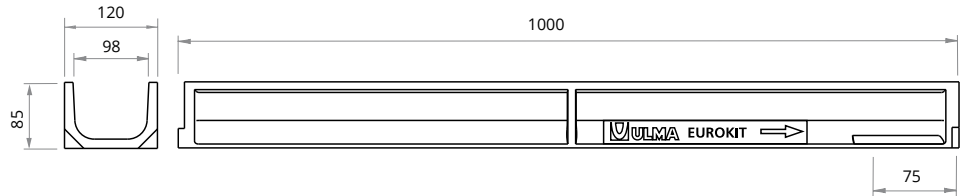

## CHANNEL

Code Channel	L mm	H mm	Width mm		Ø Outlet* mm		Hydraul. Section cm²	Pcs. pallet with grating	Weight Kg	Qref l/s
			Ext.	Int.	Vert.	Hor.				
EUROKIT	1000	85	120	98	110	-	66,5	108	6,4	1,98

\* Vertical outlets on order

## GRATING

Slotted



Material	Design	Load	Code	L mm	Width mm	Thickness mm	Opening mm	Weight Kg	Intake area cm²/ml
GALVANISED STEEL	SLOTTED	A15	GNS100UOA	1000	120	3	7	1,4	213

## HOW TO FIX

Click locking system

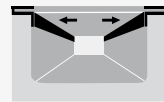

Code	Units ml
(1)	(1)

(1) Click. Without screws.

## OPEN END CAP

Code	Ø mm
TEUROKITA	60

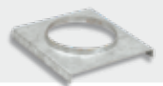

## CLOSED END CAP

Code
TEUROKITC



Load Class  
up to C250  
EN-1433 Standard

# EUROSELF



ULMA Linear Drainage Channel type EUROSELF: External width 127 mm; Internal width 100 mm and overall height 95 mm to collect rainwater in 1 metre long units. Locking system consist of locking bar and screws.

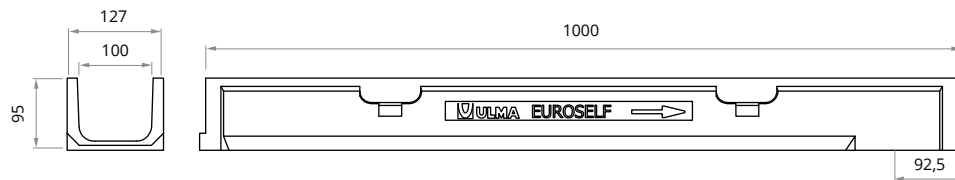

## CHANNEL

Code Channel	L mm	H mm	Width mm		Ø Outlet* mm		Hydraul. Section cm <sup>2</sup>	Pcs. pallet	Weight Kg	Qref l/s
			Ext.	Int.	Vert.	Hor.				
EUROSELF	1000	95	127	100	110	-	80	120	6,9	2,7

\* Vertical outlets on order

## GRATINGS

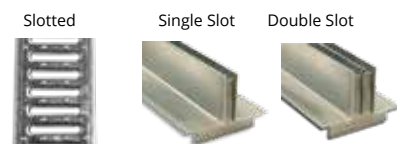

Material	Design	Load	Code	L mm	Width mm	Thickness mm	Opening mm	Weight Kg	Intake area cm <sup>2</sup> /ml
GALVANISED STEEL	SLOTTED*	A15	GN100UCA	1000	130	3	8	1,1	268
	SINGLE SLOT*	C250	GR100UOC	1000	130	70	15	4,8	150
	DOUBLE SLOT*	C250	GDR100UOC	1000	130	70	2 x 12	5,5	240

\* Available in stainless steel, consult design

## HOW TO FIX

Click locking system



Code	Units ml
(1)	(1)
(2)	(2)
(2)	(2)

(1) Click. Without screws.  
(2) Supported

## SUMP UNITS

Code	L mm	H mm	Width mm	Lateral outlets Ø mm	Front outlet Ø mm	Sump units	Weight Kg
AEURO100	500	300	130	90/110	90	1	14,4

## BUCKET

Code
CEURO100

## OPEN END CAP

Code	Ø mm
TEURO100A	90

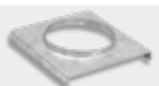

## CLOSED END CAP

Code
TEURO100C

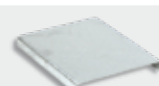

Load Class  
up to C250  
EN-1433 Standard

# EUROSELFV+



ULMA Linear Drainage Channel, type EUROSELFV+; External width 130 mm, Internal width 100 mm; Available with overall heights between 95 mm and 145 mm, to collect rainwater in 1 meter long units, optimized V-shape with self-cleaning effect; especially designed for channel runs with no longitudinal slope. Locking system consist of locking bar and screws.

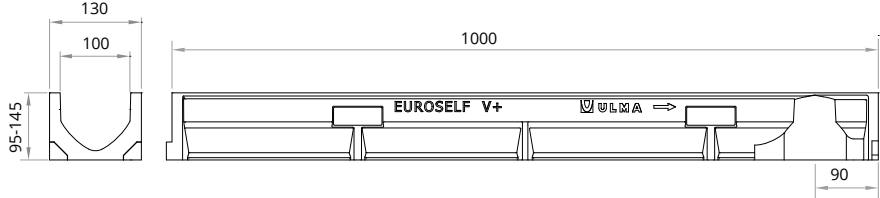

## CHANNELS

Code Channel	L mm	H mm	Width mm		Ø Outlet* mm		Hydraul. Section cm <sup>2</sup>	Pcs. pallet	Weight Kg	Qref l/s
			Ext.	Int.	Vert.	Hor.				
EUROSELFV+ H95	1000	95	130	100	110	-	66	120	7,3	2,0
EUROSELFV+ H125	1000	125	130	100	110	-	95	105	8,7	3,5
EUROSELFV+ H145	1000	145	130	100	110	-	114	90	9,7	4,7

\* Vertical outlets on order

## GRATINGS

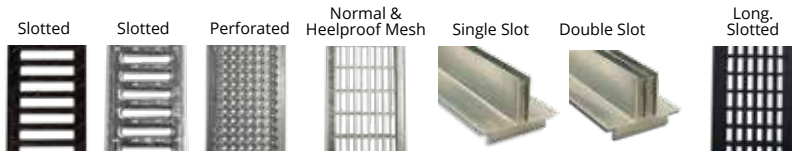

Material	Design	Load	Code	L mm	Width mm	Thickness mm	Opening mm	Weight Kg	Intake area cm <sup>2</sup> /ml
DUCTILE IRON	SLOTTED	B125	FNX100UCBM	500	130	6	14,9	2,1	530
	SLOTTED	C250	FNX100UCCM	500	130	6	13	2,7	435
GALVANISED STEEL	SLOTTED	A15	GN100UCA	1000	130	3	9	1,6	268
	PERFORATED	A15	GP100UCA	1000	130	3	Ø6	1,4	159
	MESH*	B125	GEX100UCB33	1000	130	2	30 x 30	3,2	837
	HEELPROOF MESH*	B125	GEHX100UCB	1000	130	2	30 x 10	3,9	749
	SLOT*	C250	GR100UOC	1000	130	70	15	4,8	150
	DOUBLE SLOT*	C250	GDR100UOC	1000	130	70	2 x 12	5,5	240
STAINLESS STEEL	SLOTTED	A15	IN100UCA	1000	130	3	7	1,5	218
	PERFORATED	A15	IP100UCA	1000	130	3	Ø6	1,7	159
COMPOSITE	LONG. SLOTTED BLACK	A15	PNLH100UCAM	500	130	3	8	0,3	367
	LONG. SLOTTED GREY	A15	PNLH100UCAM GRIS	500	130	3	8	0,3	367

\* Available in stainless steel, consult design

## HOW TO FIX

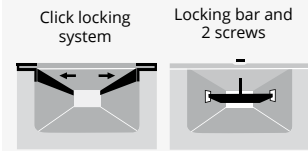

Code	Units ml
TEF840 + CS100	2 + 2
TEF840 + CS100	2 + 2
(1) TNPC850 + CS100	2 + 2
TNPC850 + CS100	2 + 2
TEF840 + CS100	2 + 2
TEF840 + CS100	2 + 2
(2)	(2)
(2)	(2)
TXNPC850 + CS100INOX	2 + 2
TXNPC850 + CS100INOX	2 + 2
(1) TXE840 + CS100INOX	2 + 2
(1) TXE840 + CS100INOX	2 + 2

(1) Click. Without screws.  
(2) Supported

## SUMP UNITS

Code	L mm	H mm	Width mm	Lateral outlets Ø mm	Front outlet Ø mm	Sump units	Weight Kg
AEURO100	500	300	130	90/110	90	1	14,4

## BUCKET

Code
CEURO100

## OPEN END CAP

Code	Ø mm
TEURO100VH95A	90
TEURO100VH125A	90
TEURO100VH145A	110

## CLOSED END CAP

Code
TEURO100VH95C
TEURO100VH125C
TEURO100VH145C

Load Class  
up to C250  
EN-1433 Standard

# DOMO



ULMA Linear Drainage Channel type DOMO: External width 130 mm; Internal width 100 mm and overall height 80 mm to collect rainwater in 1 metre long units. The locking system consists of 2 screws per metre.

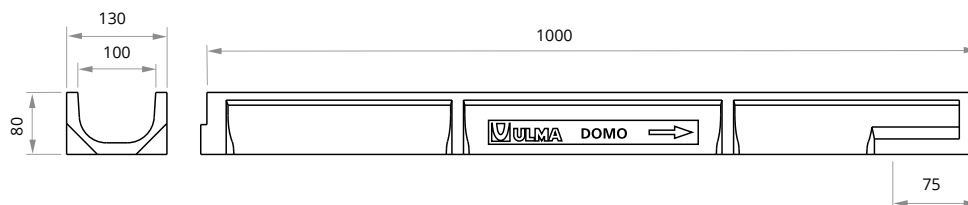

## CHANNEL

Code Channel	L mm	H mm	Width mm		Ø Outlet* mm		Hydraul. Section cm <sup>2</sup>	Pcs. pallet	Weight Kg	Qref l/s
			Ext.	Int.	Vert.	Hor.				
DOMO	1000	80	130	100	110	-	60	120	6,9	1,67

\* Vertical outlets on order

## GRATINGS



## HOW TO FIX

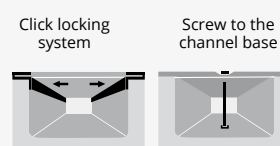

Material	Design	Load	Code	L mm	Width mm	Thickness mm	Opening mm	Weight Kg	Intake area cm <sup>2</sup> /ml	Code	Units ml
DUCTILE IRON	SLOTTED	B125	FNX100UCBM	500	130	6	14,9	2,1	530	TEF870	2
	SLOTTED	C250	FNX100UCCM	500	130	6	13	2,7	435	TEF870	2
GALVANISED STEEL	SLOTTED	A15	GN100UCA	1000	130	3	9	1,6	268	(1) TNPC875	2
	PERFORATED	A15	GP100UCA	1000	130	3	Ø6	1,4	159	TNPC875	2
	MESH*	B125	GEX100UCB33	1000	130	2	30 x 30	3,2	837	TEF860	2
	HEELPROOF MESH*	B125	GEHX100UCB	1000	130	2	30 x 10	3,9	749	TEF860	2
	SLOT*	C250	GR100UOC	1000	130	70	15	4,8	150	(2)	(2)
	DOUBLE SLOT*	C250	GDR100UOC	1000	130	70	2 x 12	5,5	240	(2)	(2)
STAINLESS STEEL	SLOTTED	A15	IN100UCA	1000	130	3	7	1,5	218	TXNPC875	2
	PERFORATED	A15	IP100UCA	1000	130	3	Ø6	1,7	159	TXNPC875	2
COMPOSITE	LONG. SLOTTED BLACK	A15	PNLH100UCAM	500	130	3	8	0,3	367	(1) TXNPC870	2
	LONG. SLOTTED GREY	A15	PNLH100UCAM GRIS	500	130	3	8	0,3	367	(1) TXNPC870	2

\* Available in stainless steel, consult design

(1) Click. Without screws.  
(2) Supported

## SUMP UNITS

Code	L mm	H mm	Width mm	Lateral outlets Ø mm	Front outlet Ø mm	Sump units	Weight Kg
AEURO100	500	300	130	90/110	90	1	14,4

## BUCKET

Code
CEURO100

## CLOSED END CAP

Code
TDOMO100C



Load Class  
up to C250  
EN-1433 Standard

# SELF



ULMA Linear Drainage Channel type SELF: External width 130 mm; Internal width 100 mm and overall height 115 mm to collect rainwater in 1 metre long units. Locking system consists of locking bar CS100 and screws.

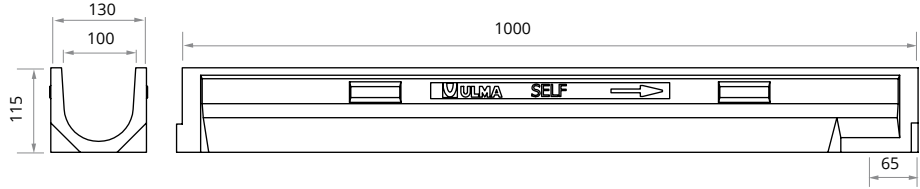

## CHANNEL

Code Channel	L mm	H mm	Width mm		Ø Outlet* mm		Hydraul. Section cm <sup>2</sup>	Pcs. pallet	Weight Kg	Qref l/s
			Ext.	Int.	Vert.	Hor.				
SELF	1000	115	130	100	110	-	85	105	8,4	3,0

\* Vertical outlets on order

## GRATINGS

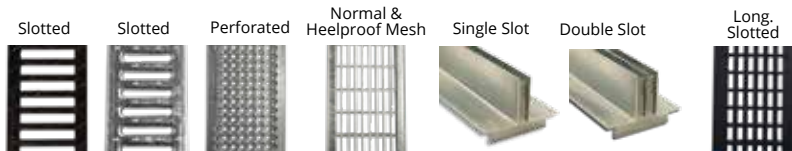

Material	Design	Load	Code	L mm	Width mm	Thickness mm	Opening mm	Weight Kg	Intake area cm <sup>2</sup> /ml
DUCTILE IRON	SLOTTED	B125	FNX100UCBM	500	130	6	14,9	2,1	530
	SLOTTED	C250	FNX100UCCM	500	130	6	13	2,7	435
GALVANISED STEEL	SLOTTED	A15	GN100UCA	1000	130	3	9	1,6	268
	PERFORATED	A15	GP100UCA	1000	130	3	Ø6	1,4	159
	MESH*	B125	GEX100UCB33	1000	130	2	30 x 30	3,2	837
	HEELPROOF MESH*	B125	GEHX100UCB	1000	130	2	30 x 10	3,9	749
	SLOT*	C250	GR100UOC	1000	130	70	15	4,8	150
	DOUBLE SLOT*	C250	GDR100UOC	1000	130	70	2 x 12	5,5	240
STAINLESS STEEL	SLOTTED	A15	IN100UCA	1000	130	3	7	1,5	218
	PERFORATED	A15	IP100UCA	1000	130	3	Ø6	1,7	159
COMPOSITE	LONG. SLOTTED BLACK	A15	PNLH100UCAM	500	130	3	8	0,3	367
	LONG. SLOTTED GREY	A15	PNLH100UCAM-GRIS	500	130	3	8	0,3	367

\* Available in stainless steel, consult design

## HOW TO FIX

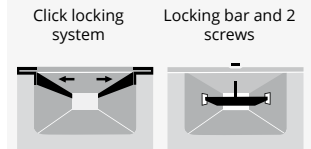

Code	Units ml
TEF840 + CS100	2 + 2
TEF840 + CS100	2 + 2
(1) TNPC850 + CS100	2 + 2
TNPC850 + CS100	2 + 2
TEF840 + CS100	2 + 2
TEF840 + CS100	2 + 2
(2)	(2)
(2)	(2)
TXNPC850 + CS100INOX	2 + 2
TXNPC850 + CS100INOX	2 + 2
(1) TXE840 + CS100INOX	2 + 2
(1) TXE840 + CS100INOX	2 + 2

(1) Click. Without screws.

(2) Supported

## SUMP UNITS

Code	L mm	H mm	Width mm	Lateral outlets Ø mm	Front outlet Ø mm	Sump units	Weight Kg
AEURO100	500	300	130	90/110	90	1	14,4

## BUCKET

Code
CEURO100

## OPEN END CAP

Code	Ø mm
TSELF100A	90

## CLOSED END CAP

Code
TSELF100C

Load Class  
up to C250  
EN-1433 Standard

# SELFK



ULMA Linear Drainage Channel type SELFK: External width 130 mm; Internal width 100 mm and overall height 100 mm to collect rainwater in 1 metre long units. Integrated galvanised steel\* edges for lateral protection. Locking system consists of 2 screws per metre.

\*Also available with stainless steel edge protection

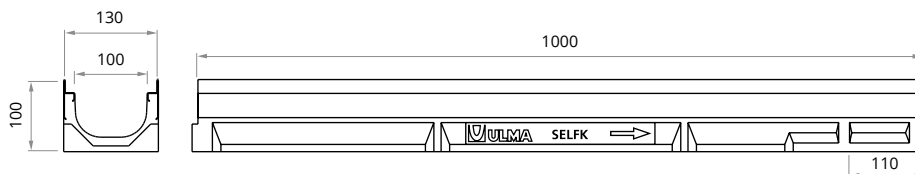

## CHANNEL

Code Channel	L mm	H mm	Width mm		Ø Outlet* mm		Hydraul. Section cm <sup>2</sup>	Pcs. pallet	Weight Kg	Qref l/s
			Ext.	Int.	Vert.	Hor.				
SELFK	1000	100	130	100	110	-	53	105	11,1	1,5

\* Vertical outlets on order

## GRATINGS

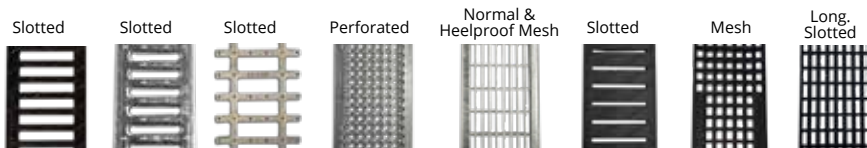

Material	Design	Load	Code	L mm	Width mm	Opening mm	Weight Kg	Intake area cm <sup>2</sup> /ml	HOW TO FIX	
									Code	Units ml
DUCTILE IRON	SLOTTED	B125	FNX100KCBM	500	123	14	2,7	476	TEF880	2
	SLOTTED	C250	FNX100KCCM	500	123	14	2,9	486	TEF880	2
	HEELPROOF SLOTTED	C250	FNHX100KCCM	500	123	5	3,7	174	TEF880	2
STAINLESS DUCTILE IRON	SLOTTED	D400	FIN100KCDM	500	123	19,9	3,5	695	TXE880	2
GALVANISED STEEL	PERFORATED	A15	GP100KCA	1000	123	Ø6	1,1	158	TNPC890	2
	SLOTTED	A15	GN100KCA	1000	123	9	1,6	282	TNPC890	2
	MESH*	B125	GEX100KCB	1000	123	30 x 20	3,3	823	TEF880	2
	HEELPROOF MESH *	B125	GEHX100KCB	1000	123	30 x 10	4,0	743	TEF880	2
STAINLESS STEEL	SLOTTED	A15	IN100KCA	1000	123	7	1,4	216	TXNPC890	2
	PERFORATED	A15	IP100KCA	1000	123	Ø6	1,2	158	TXNPC890	2
COMPOSITE	HEELPROOF SLOTTED BLACK	A15	PNH100KCAM	500	123	5	0,6	159	TXE880	2
	HEELPROOF SLOTTED GRAY	A15	PNH100KCAM-GRIS	500	123	5	0,6	159	TXE880	2
	LONG.SLOTTED BLACK	A15	PNLH100KCAM	500	123	8	0,3	484	TXE880	2
	LONG.SLOTTED GRAY	A15	PNLH100KCAM-GRIS	500	123	8	0,3	484	TXE880	2
	MESH	B125	PE100KCBM	500	123	14 x 12,5	0,5	553	TXE880	2

\* Available in stainless steel, consult design

## HOW TO FIX

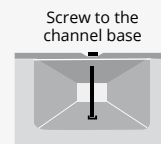

## SUMP UNITS

	Code	L mm	H mm	Width mm	Lateral outlets Ø mm	Front outlet Ø mm	Sump units	Weight Kg
	AEURO100K	500	318	130	90/110	90	1	15,2

## BUCKET

	Code
	CEURO100

## CLOSED END CAP

Code	
TSELF100KC	



Load Class up to C250  
EN-1433 Standard

# EUROSELF200



ULMA Linear Drainage Channel type EUROSELF200: External width 200 mm; Internal width 150 mm and overall height 70 mm to collect rainwater in 1 metre long units. Locking system consists of 2 screws per metre.

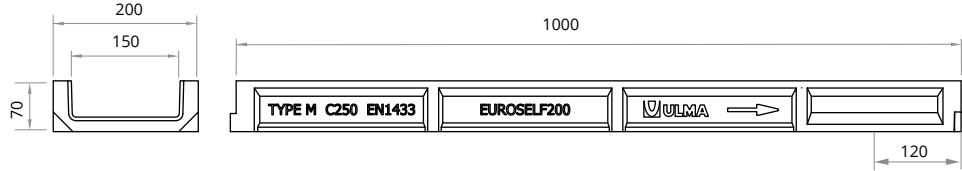

## CHANNEL

Code Channel	L mm	H mm	Width mm		Ø Outlet* mm		Hydraul. Section cm²	Pcs. pallet	Weight Kg	Qref l/s
			Ext.	Int.	Vert.	Hor.				
EUROSELF200	1000	70	200	150	160	-	75	81	12,0	1,9

\* Vertical outlets on order

## GRATINGS

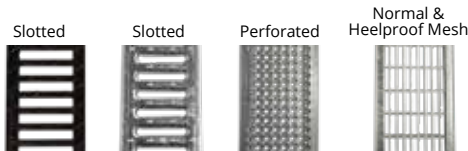

Material	Design	Load	Code	L mm	Width mm	Thickness mm	Opening mm	Weight Kg	Intake area cm²/ml
DUCTILE IRON	SLOTTED	B125	FNX150UCBM	500	200	6	13,75	4,0	683
	SLOTTED	C250	FNX150UCCM	500	200	5	13,75	4,4	683
GALVANISED STEEL	SLOTTED*	A15	GN150UCA	1000	200	3	8	3,4	392
	PERFORATED	A15	GP150UCA	1000	200	3	Ø5	4,2	196
	MESH*	B125	GEX150UCB33	1000	200	2	30 x 30	5,0	1254
	HEELPROOF MESH	B125	GEHX150UCB	1000	200	2	30 x 10	6,2	1116
STAINLESS STEEL	PERFORATED	A15	IP150UCA	1000	200	3	Ø5	4,4	196

\* Available in stainless steel, consult design

## HOW TO FIX

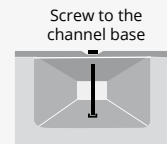

Code	Units ml
TEF850	2
TEF850	2
(1) TNPC860	2
TNPC860	2
TEF850	2
TEF850	2
TXNPC850	2

(1) Click. Without screws.

## CLOSED END CAP

Code
TEUROSELF200C





Load Class  
up to C250  
EN-1433 Standard

# SELF200

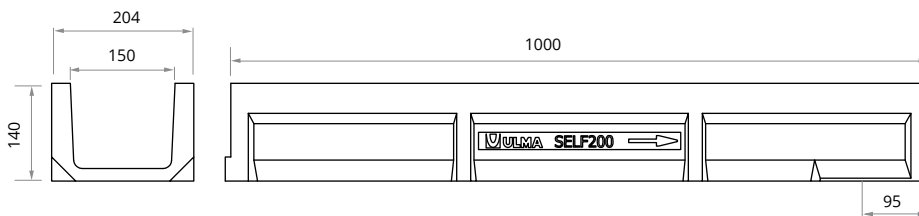

ULMA Linear Drainage Channel type SELF200: External width 204 mm; Internal width 150 mm and overall height 140 mm to collect rainwater in 1 metre long units. Locking system consists of locking bar CS150 and screws.



## CHANNEL

Code Channel	L mm	H mm	Width mm		Ø Outlet* mm		Hydraul. Section cm <sup>2</sup>	Pcs. pallet	Weight Kg	Qref l/s
			Ext.	Int.	Vert.	Hor.				
SELF200	1000	140	204	150	160	-	180	54	16,2	7,6

\* Vertical outlets on order

## GRATINGS

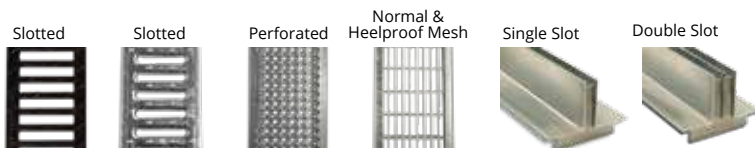

Material	Design	Load	Code	L mm	Width mm	Thickness mm	Opening mm	Weight Kg	Intake area cm <sup>2</sup> /ml
DUCTILE IRON	SLOTTED	B125	FNX150UCBM	500	200	6	13,75	4,0	683
	SLOTTED	C250	FNX150UCCM	500	200	5	13,75	4,4	683
GALVANISED STEEL	SLOTTED*	A15	GN150UCA	1000	200	3	8	3,4	392
	PERFORATED	A15	GP150UCA	1000	200	3	Ø5	4,2	196
	MESH*	B125	GEX150UCB33	1000	200	2	30 x 30	5,0	1254
	HEELPROOF MESH	B125	GEHX150UCB	1000	200	2	30 x 10	6,2	1116
	SLOT*	C250	GR150UOC	1000	200	70	15	6,2	150
	DOUBLE SLOT*	C250	GDR150UOC	1000	200	70	2 x 12	7,0	240
STAINLESS STEEL	PERFORATED	A15	IP150UCA	1000	200	3	Ø5	4,4	196

\* Available in stainless steel, consult design

## HOW TO FIX

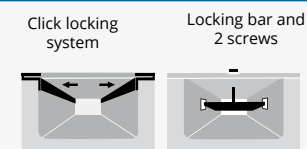

Code	Units ml
TEF850 + CS150	2 + 2
TEF850 + CS150	2 + 2
(1) TNPC860 + CS150	2 + 2
TNPC860 + CS150	2 + 2
TEF850 + CS150	2 + 2
TEF850 + CS150	2 + 2
(1)	(1)
(1)	(1)
TXNPC850 + CS150INOX	2 + 2

(1) Click. Without screws.

## SUMP UNITS

Code	L mm	H mm	Width mm	Lateral outlets Ø mm	Front outlet Ø mm	Sump units	Weight Kg
ASELF200	500	378	204	160/200	160	1	27,7



## BUCKET

Code
CSELF200



## OPEN END CAP

Code	Ø mm
TSELF200A	110

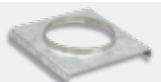

## CLOSED END CAP

Code
TSELF200C



Load Class  
up to C250  
EN-1433 Standard

# SELF200K



ULMA Linear Drainage Channel type SELF200K: External width 204 mm; Internal width 150 mm and overall height 162 mm to collect rainwater in 1 metre long units. Integrated galvanised steel\* edges for lateral protection. Locking system consists of locking bar CS150 and screws.

\*Also available with stainless steel edge protection.

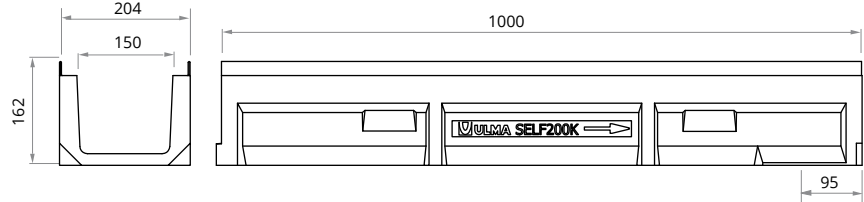

## CHANNEL

Code Channel	L mm	H mm	Width mm		Ø Outlet* mm		Hydraul. Section cm <sup>2</sup>	Pcs. pallet	Weight Kg	Qref l/s
			Ext.	Int.	Vert.	Hor.				
SELF200K	1000	162	204	150	160	-	180	40	19,7	7,6

\* Vertical outlets on order

## GRATINGS

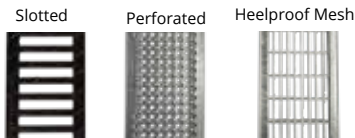

Material	Design	Load	Code	L mm	Width mm	Opening mm	Weight Kg	Intake area cm <sup>2</sup> /ml
DUCTILE IRON	SLOTTED	C250	FNX150KCCM	500	195	14	5,2	720
	PERFORATED	A15	GP150KCA	1000	195	Ø5	4,1	196
GALVANISED STEEL	MESH	B125	GEX150KCB	1000	195	30 x 20	5,6	1413
	HEELPROOF MESH*	B125	GEHX150KCB	1000	195	30 x 10	6,6	1133
STAINLESS STEEL	PERFORATED	A15	IP150KCA	1000	195	Ø5	4,1	196

\* Available in stainless steel, consult design

## HOW TO FIX

Locking bar and 2 screws



Code	Units ml
TEF880 + CS150	2 + 2
TNPC890 + CS150	2 + 2
TEF880 + CS150	2 + 2
TEF880 + CS150	2 + 2
TXNPC890 + CS150INOX	2 + 2

## SUMP UNITS

Code	L mm	H mm	Width mm	Lateral outlets Ø mm	Front outlet Ø mm	Sump units	Weight Kg
ASELF200K	500	400	204	160/200	160	1	28,9

## BUCKET

Code
CSELF200

## OPEN END CAP

Code	Ø mm
TSELF200KA	110

## CLOSED END CAP

Code
TSELF200KC



Load Class  
up to C250  
EN-1433 Standard

# SELF250



ULMA Linear Drainage Channel type SELF250: External width 260 mm; Internal width 200 mm and overall height 155 mm to collect rainwater in 1 metre long units. Locking system consists of locking bar CS200 and screws.

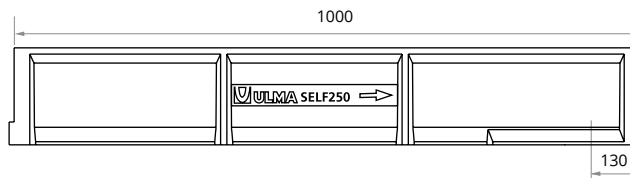
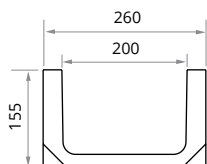

## CHANNEL

Code Channel	L mm	H mm	Width mm		Ø Outlet* mm		Hydraul. Section cm <sup>2</sup>	Pcs. pallet	Weight Kg	Qref l/s
			Ext.	Int.	Vert.	Hor.				
SELF250	1000	155	260	200	200	-	260	35	22,5	12,6

\* Vertical outlets on order

## GRATINGS



Material	Design	Load	Code	L mm	Width mm	Thickness mm	Opening mm	Weight Kg	Intake area cm <sup>2</sup> /ml
DUCTILE IRON	SLOTTED	C250	FNX200UCCM	500	250	6	10	6,7	610
GALVANISED STEEL	SLOTTED*	A15	GN200UCA	1000	250	4	8,5	5,2	418
	MESH*	B125	GEX200UCB33	1000	250	2,5	30 x 30	8,0	1634
	HEELPROOF MESH *	B125	GEHX200UCB	1000	250	2,5	30 x 10	9,5	1453
	SLOT*	C250	GR200UOC	1000	250	70	15	7,9	150
	DOUBLE SLOT*	C250	GDR200UOC	1000	250	70	2x12	10,0	240

\* Available in stainless steel, consult design

## HOW TO FIX

Locking bar and 2 screws

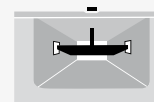

Code	Units ml
TEF1060 + CS200	2 + 2
TNPC1070 + CS200	2 + 2
TEF1060 + CS200	2 + 2
TEF1060 + CS200	2 + 2
(1)	(1)
(1)	(1)

(1) Click. Without screws.

## OPEN END CAP

Code	Ø mm
TSELF250A	160

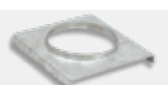

## CLOSED END CAP

Code
TSELF250C

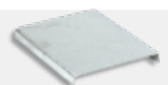

Load Class  
up to C250  
EN-1433 Standard

# SELF250K



ULMA Linear Drainage Channel type SELF250K: External width 260 mm; Internal width 200 mm and overall height 180 mm to collect rainwater in 1 metre long units. Integrated galvanised steel edges for lateral protection. Locking system consists of locking bar CS200 and screws.

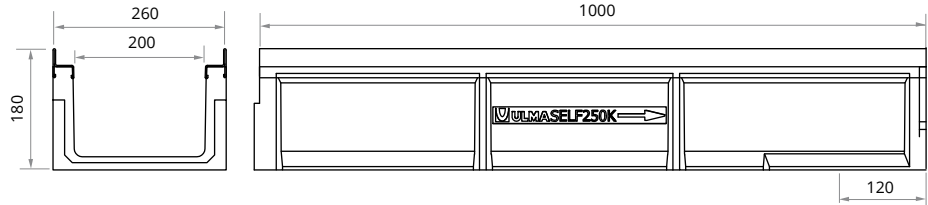

## CHANNEL

Code Channel	L mm	H mm	Width mm		Ø Outlet* mm		Hydraul. Section cm <sup>2</sup>	Pcs. pallet	Weight Kg	Qref l/s
			Ext.	Int.	Vert.	Hor.				
SELF250K	1000	180	260	200	160/200	-	260	28	27,5	12,6

\* Vertical outlets on order

## GRATINGS

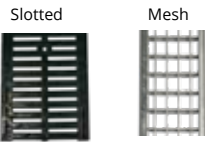

Material	Design	Load	Code	L mm	Width mm	Opening mm	Weight Kg	Intake area cm <sup>2</sup> /ml
DUCTILE IRON	SLOTTED	C250	FNX200KCCM	500	250	14	7,2	919
GALVANISED STEEL	MESH*	B125	GEX200KCB	1000	250	30 x 20	8,0	1846

\* Available in stainless steel, consult design

## HOW TO FIX

Locking bar and 2 screws



Code	Units ml
TEF1080 + CS200	2 + 2
TEF1080 + CS200	2 + 2

## SUMP UNITS

Code	L mm	H mm	Width mm	Lateral outlets Ø mm	Front outlet Ø mm	Sump units	Weight Kg
ASELF250K	500	500	260	315	160	1	47,9

## BUCKET

Code
CSELF250

## OPEN END CAP

Code	Ø mm
TSELF250KA	160

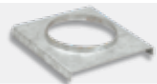

## CLOSED END CAP

Code
TSELF250KC

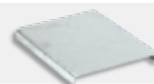

Load Class  
up to C250  
EN-1433 Standard

# SELF300



ULMA Linear Drainage Channel type SELF300: External width 300 mm; Internal width 250 mm and overall height 190 mm to collect rainwater in 1 metre long units. Locking system consists of locking bar CS250 and screws.

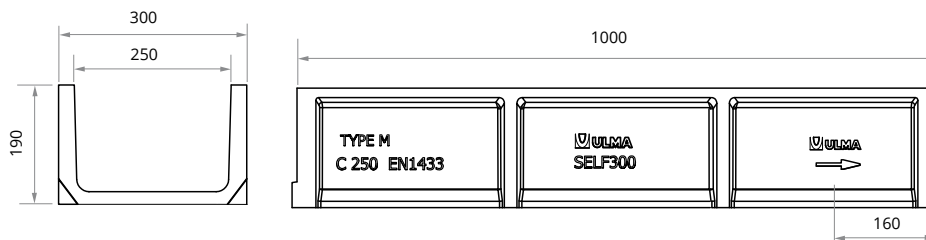

## CHANNEL

Code Channel	L mm	H mm	Width mm		Ø Outlet* mm		Hydraul. Section cm <sup>2</sup>	Pcs. pallet	Weight Kg	Qref l/s
			Ext.	Int.	Vert.	Hor.				
SELF300	1000	190	300	250	200	-	407	35	26,1	22,5

\* Vertical outlets on order

## GRATINGS

Slotted



Mesh



Material	Design	Load	Code	L mm	Width mm	Thickness mm	Opening mm	Weight Kg	Intake area cm <sup>2</sup> /ml	HOW TO FIX	
										Code	Units ml
DUCTILE IRON	SLOTTED	B125	FNX250UCBM	500	300	6	13,2	8,4	1049	TEF1070 + CS250	2 + 2
	SLOTTED	C250	FNX250UCCM	500	300	6	14	10,5	1004	TEF1070 + CS250	2 + 2
GALVANISED STEEL	MESH*	B125	GEX250UCB	1000	300	3	30 x 20	12,3	1993	TEF1070 + CS250	2 + 2

\* Available in stainless steel, consult design

## HOW TO FIX

Locking bar and 2 screws

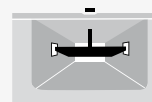

## SUMP UNITS

Code	L mm	H mm	Width mm	Lateral outlets Ø mm	Front outlet Ø mm	Sump units	Weight Kg	BUCKET	
								Code**	Weight Kg
AU250	500	375	310	160/200	-	1	36,5	C250	62,7
AU250S + A250B	500	725*	310	160/200	-	2			

\* The sump unit can be higher incorporating an intermediate unit.

## BUCKET



\*\* Only applicable if 2 sump units are installed.

## OPEN END CAP

Code	Ø mm	Image
TSELF300A	160	

## CLOSED END CAP

Code	Image
TSELF300C	



Load Class  
up to C250  
EN-1433 Standard

# SELF350K

ULMA Linear Drainage Channel type SELF350K: External width 362 mm; Internal width 300 mm and overall height 210 mm to collect rainwater in 1 metre long units. Integrated galvanised steel edges for lateral protection. Locking system consists of locking bar CS300 and screws.

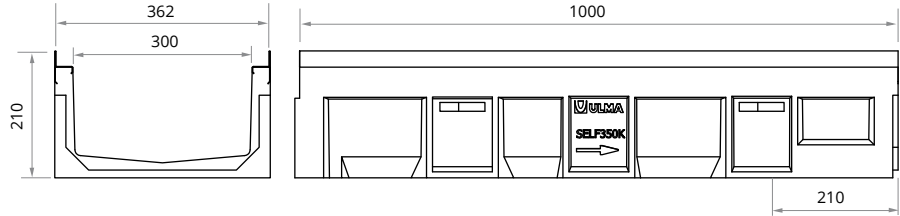

## CHANNEL

Code Channel	L mm	H mm	Width mm		Ø Outlet* mm		Hydraul. Section cm <sup>2</sup>	Pcs. pallet	Weight Kg	Qref l/s
			Ext.	Int.	Vert.	Hor.				
SELF350K	1000	210	362	300	250	-	455	21	40,3	23,3

\* Vertical outlets on order

## GRATINGS

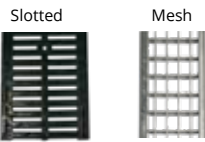

Material	Design	Load	Code	L mm	Width mm	Opening mm	Weight Kg	Intake area cm <sup>2</sup> /ml	Code	Units ml
DUCTILE IRON	SLOTTED	C250	FNX300KCCM	500	351	14	15,3	1368	TEF1090 + CS300	2 + 2
GALVANISED STEEL	MESH*	B125	GEX300KCB	1000	351	30 x 20	13,2	2672	TEF1090 + CS300	2 + 2

\* Available in stainless steel, consult design

## HOW TO FIX

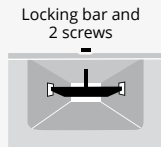

## SUMP UNITS

Code	L mm	H mm	Width mm	Lateral outlets Ø mm	Front outlet Ø mm	Sump units	Weight Kg
ASELF350K	500	500	362	315	160/200	1	56,3

## BUCKET

Code
CSELF350

## OPEN END CAP

Code	Ø mm
TSELF350KA	160

## CLOSED END CAP

Code
TSELF350KC



# SUMP UNITS

## AEURO100 / AEURO100K

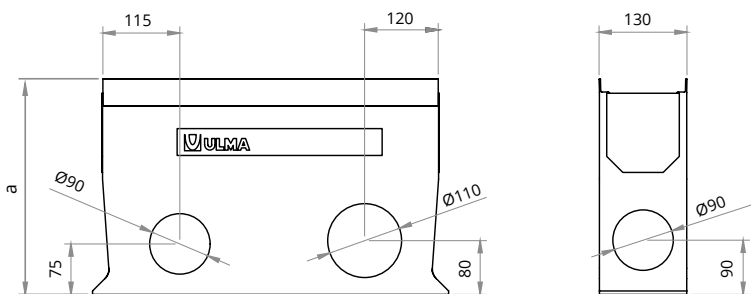

Code Channel	a mm
AEURO100	300
AEURO100K	318

## ASELF200 / ASELF200K

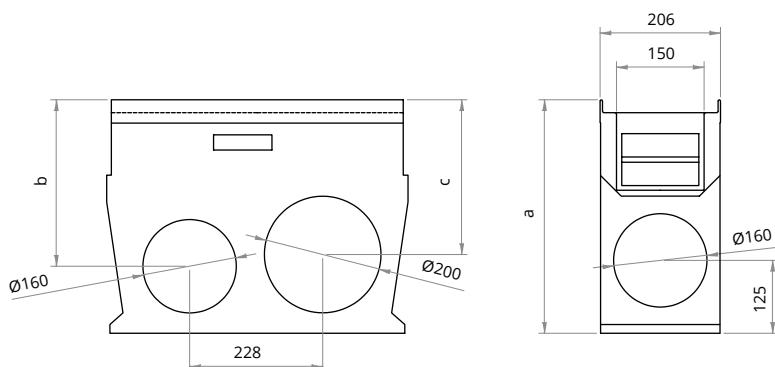

Code Channel	a mm	b mm	c mm
ASELF200	370	255	235
ASELF200K	400	285	265

## ASELF250K / ASELF350K

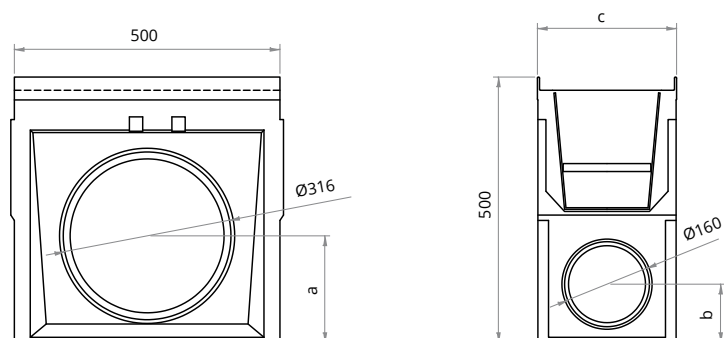

Code Channel	a mm	b mm	c mm
ASELF250K	200	110	260
ASELF350K	185	105	362

## AU250S + A250I + A250B

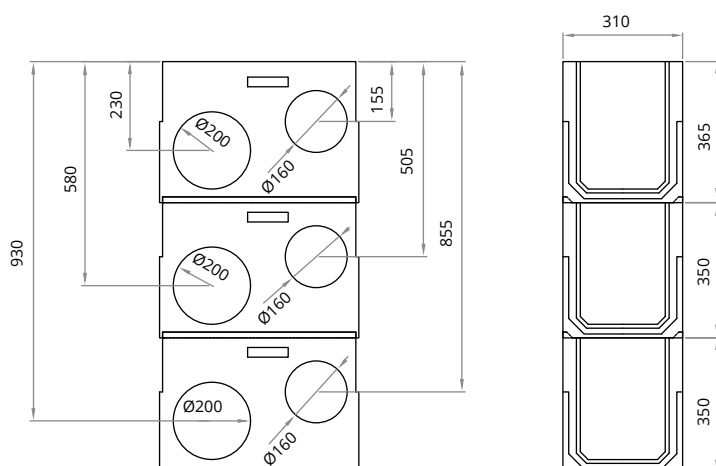

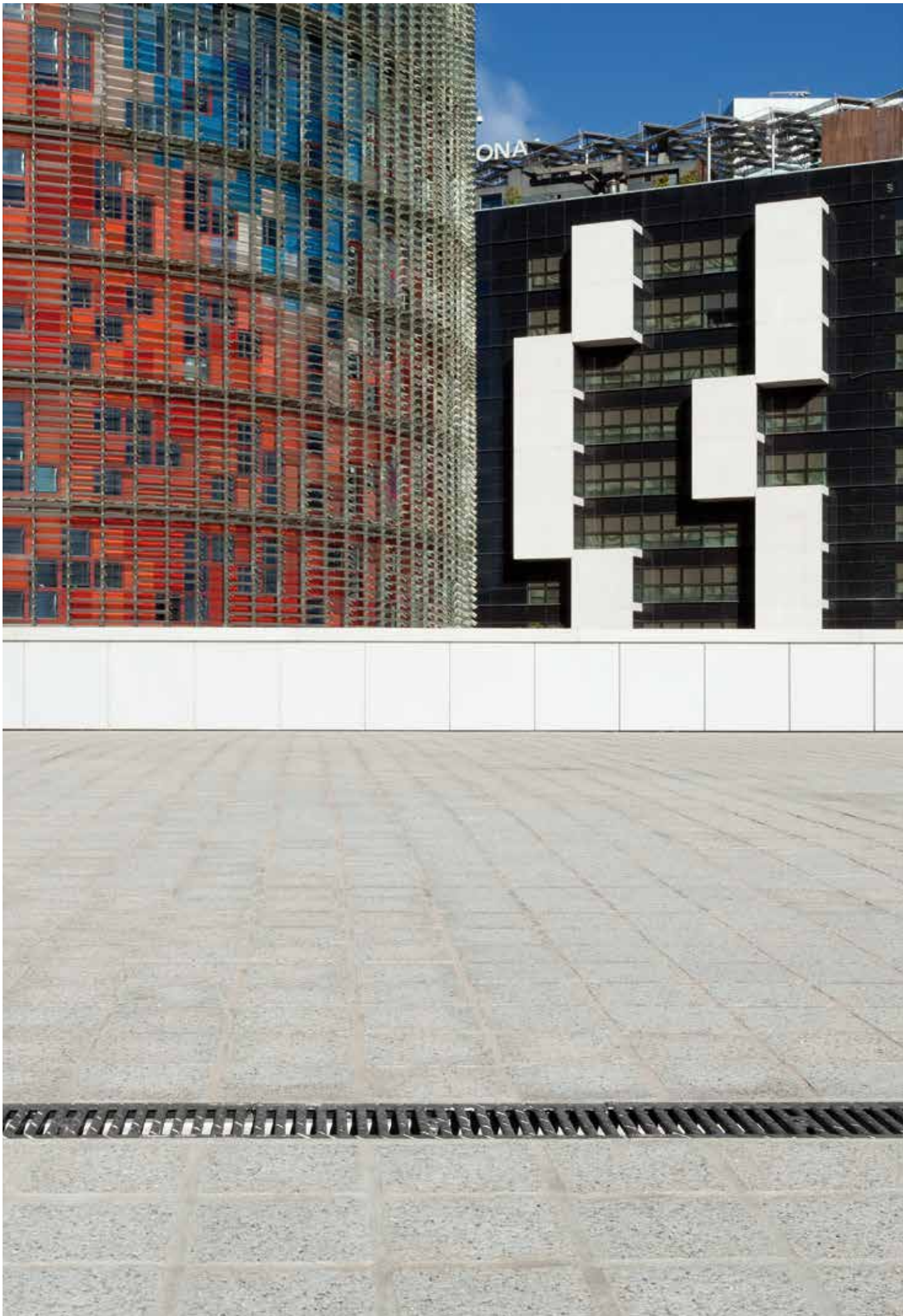

# MINI

## SYSTEM

**Housing estates, pedestrian walkways, squares,  
car parks, accesses...**

Channels specially designed for areas with limited height, such as reinforced slabs and floors of garages, basements, showers, changing rooms, inverted roofs, etc.

Channels from 5 cm. (MINIKIT model) to 15 cm. in height.

All types of grating, materials (cast iron, galvanised steel, stainless steel, etc.) and load classes up to C 250 available.

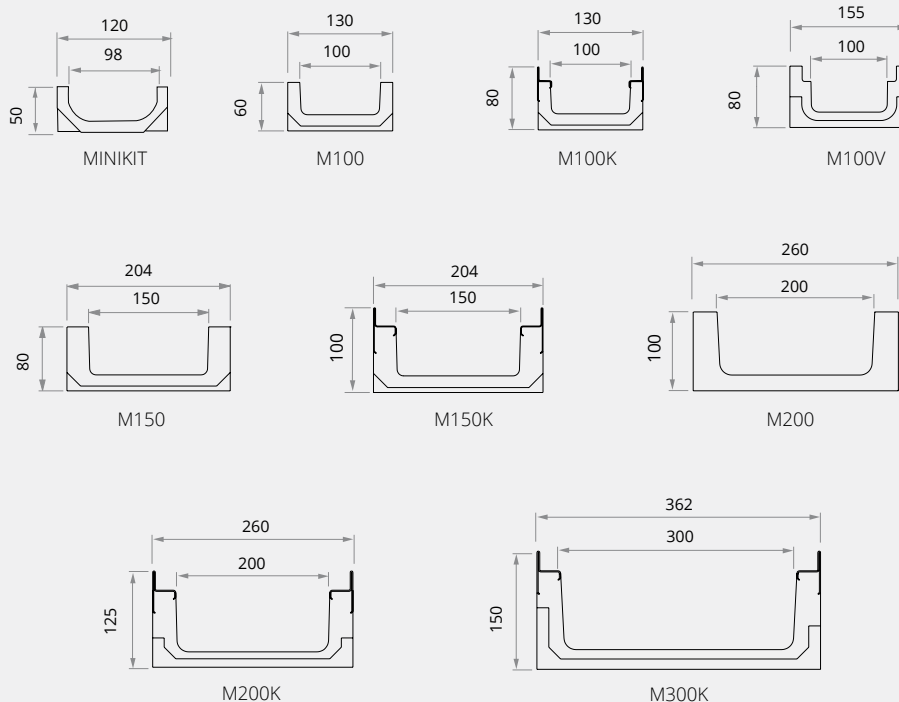

Load Class  
up to A15  
EN-1433 Standard

# MINIKIT



ULMA Linear Drainage Channel type MINIKIT: External width 120 mm; Internal width 98 mm and overall height 50 mm to collect rainwater in 1 metre long units. Locking system "click" type without screws.

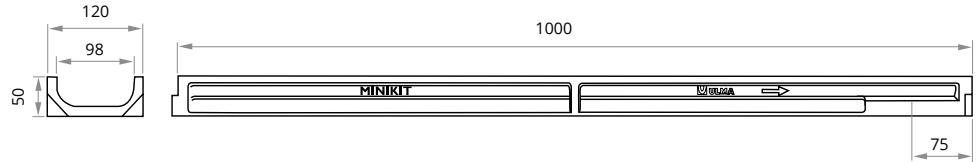

## CHANNEL

Code Channel	L mm	H mm	Width mm		Ø Outlet* mm		Hydraul. Section cm <sup>2</sup>	Pcs. pallet with grating	Weight Kg	Qref l/s
			Ext.	Int.	Vert.	Hor.				
MINIKIT	1000	50	120	98	110	-	34	126	4,6	0,5

\* Vertical outlets on order

## GRATING

Slotted



Material	Design	Load	Code	L mm	Width mm	Thickness mm	Opening mm	Weight Kg	Intake area cm <sup>2</sup> /ml
GALVANISED STEEL	SLOTTED	A15	GNS100UOA	1000	120	3	7	1,4	213

## HOW TO FIX

Click locking system



Code	Units ml
(1)	(1)

(1) Click. Without screws.

## CLOSED END CAP

Code	Image
TMINIKITC	



Load Class  
up to C250  
EN-1433 Standard

# M100

ULMA Linear Drainage Channel type M100: External width 130 mm; Internal width 100 mm and overall height 60 mm to collect rainwater in 1 metre long units. Locking system consists of 2 screws per metre.

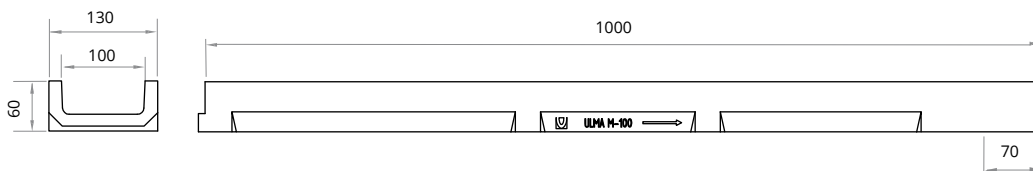

## CHANNEL

Code Channel	L mm	H mm	Width mm		Ø Outlet* mm		Hydraul. Section cm <sup>2</sup>	Pcs. pallet	Weight Kg	Qref l/s
			Ext.	Int.	Vert.	Hor.				
M100	1000	60	130	100	90	-	40	120	8,3	0,8

\* Vertical outlets on order

## GRATING

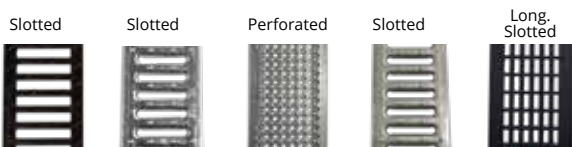

Material	Design	Load	Code	L mm	Width mm	Thickness mm	Opening mm	Weight Kg	Intake area cm <sup>2</sup> /ml
DUCTILE IRON	SLOTTED	B125	FNX100UCBM	500	130	6	14,9	2,1	530
	SLOTTED	C250	FNX100UCCM	500	130	7	13	2,7	435
GALVANISED STEEL	SLOTTED	A15	GN100UCA	1000	130	3	9	1,6	268
	PERFORATED	A15	GP100UCA	1000	130	3	Ø6	1,4	159
STAINLESS STEEL	SLOTTED	A15	IN100UCA	1000	130	3	7	1,5	218
	PERFORATED	A15	IP100UCA	1000	130	3	Ø6	1,7	159
COMPOSITE	LONG. SLOTTED BLACK	A15	PNLH100UCAM	500	130	3	8	0,3	367
	LONG. SLOTTED GRAY	A15	PNLH100UCAM GRIS	500	130	3	8	0,3	367

## HOW TO FIX

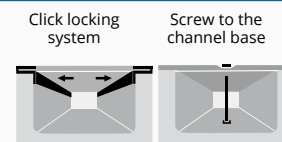

Code	Units ml
TEF845	2
TEF845	2
(1) TNPC850	2
TNPC850	2
TXNPC850	2
TXNPC850	2
(1) TXE840	2
(1) TXE840	2

(1) Click. Without screws.

## CLOSED END CAP

Code	
T100MC	



Load Class  
up to C250  
EN-1433 Standard

# M100K



ULMA Linear Drainage Channel type M100K: External width 130 mm; Internal width 100 mm and overall height 80 mm to collect rainwater in 1 metre long units. Integrated galvanised steel\* edges for lateral protection. Locking system consists of 2 screws per metre.

\*Also available with stainless steel edge protection.

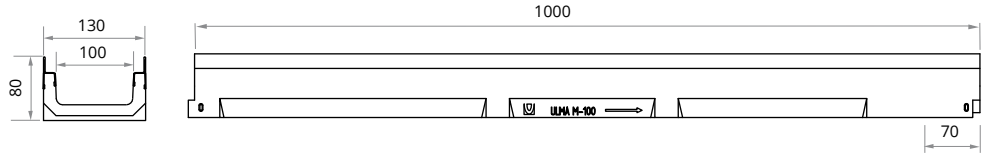

## CHANNEL

Code Channel	L mm	H mm	Width mm		Ø Outlet* mm		Hydraul. Section cm <sup>2</sup>	Pcs. pallet	Weight Kg	Qref l/s
			Ext.	Int.	Vert.	Hor.				
M100K	1000	80	130	100	90	-	40	120	9,8	0,8

\* Vertical outlets on order

## GRATING

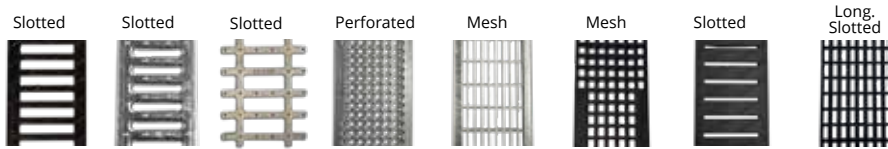

Material	Design	Load	Code	L mm	Width mm	Opening mm	Weight Kg	Intake area cm <sup>2</sup> /ml
DUCTILE IRON	SLOTTED	B125	FNX100KCBM	500	123	14	2,7	476
	SLOTTED	C250	FNX100KCCM	500	123	14	2,9	486
	HEELPROOF SLOTTED	C250	FNHX100KCCM	500	123	5	3,7	174
DUCTILE IRON STAINLESS	SLOTTED	D400	FIN100KCDM	500	123	19,9	3,5	695
GALVANISED STEEL	PERFORATED	A15	GP100KCA	1000	123	Ø6	1,1	158
	SLOTTED	A15	GN100KCA	1000	123	9	1,6	282
	MESH	B125	GEX100KCB	1000	123	30 x 20	3,3	823
	HEELPROOF MESH *	B125	GEHX100KCB	1000	123	30 x 10	4,0	743
STAINLESS STEEL	SLOTTED	A15	IN100KCA	1000	123	7	1,4	216
	PERFORATED	A15	IP100KCA	1000	123	Ø6	1,2	158
COMPOSITE	HEELPROOF SLOTTED BLACK	A15	PNH100KCAM	500	123	5	0,6	159
	HEELPROOF SLOTTED GREY	A15	PNH100KCAM-GRIS	500	123	5	0,6	159
	LONG. SLOTTED BLACK	A15	PNLH100KCAM	500	123	8	0,3	484
	LONG. SLOTTED GREY	A15	PNLH100KCAM-GRIS	500	123	8	0,3	484
	MESH	B125	PE100KCBM	500	123	14 x 12,5	0,5	553

\* Available in stainless steel, consult design

## HOW TO FIX

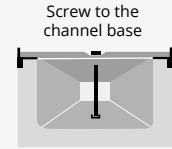

Code	Units ml
TEF860	2
TEF860	2
TEF860	2
TXE860	2
TNPC870	2
TNPC860	2
TEF855	2
TEF855	2
TXNPC860	2
TXNPC870	2
TXE860	2
TXE860	2
TXE860	2
TXE860	2
TXE860	2

## CLOSED END CAP

Code
T100MKC





Load Class  
up to C250  
EN-1433 Standard

# M100V

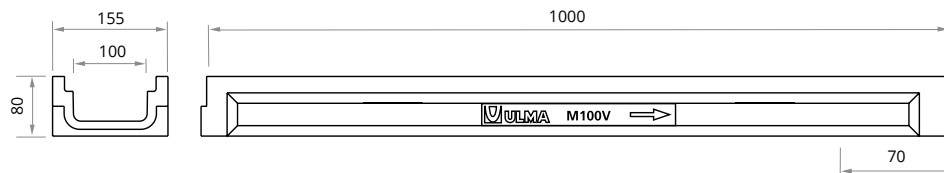

ULMA Linear Drainage Channel type M100V: External width 155 mm; Internal width 100 mm and overall height 80 mm to collect rainwater in 1 metre long units. Locking system consists of 2 screws per metre.



## CHANNEL

Code Channel	L mm	H mm	Width mm		Ø Outlet* mm		Hydraul. Section cm <sup>2</sup>	Pcs. pallet	Weight Kg	Qref l/s
			Ext.	Int.	Vert.	Hor.				
M100V	1000	80	155	100	90	-	40	120	11,5	0,8

\* Vertical outlets on order

## GRATING

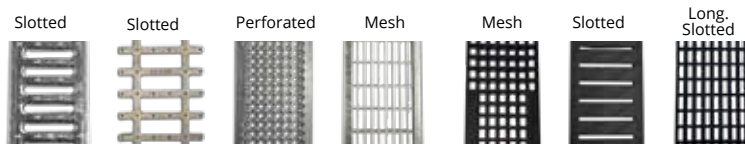

## HOW TO FIX

Screw to the channel base

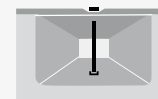

Material	Design	Load	Code	L mm	Width mm	Opening mm	Weight Kg	Intake area cm <sup>2</sup> /ml	Code	Units ml
DUCTILE IRON STAINLESS	SLOTTED	D400	FIN100KCDM	500	123	19,9	3,5	695	TXE860	2
	PERFORATED	A15	GP100KCA	1000	123	Ø 6	1,1	158	TNPC870	2
GALVANISED STEEL	SLOTTED	A15	GN100KCA	1000	123	9	1,6	282	TNPC860	2
	MESH	B125	GEX100KCB	1000	123	30 x 20	3,3	823	TEF860	2
	HEELPROOF MESH*	B125	GEHX100KCB	1000	123	30 x 10	4,0	743	TEF860	2
STAINLESS STEEL	SLOTTED	A15	IN100KCA	1000	123	7	1,4	216	TXNPC860	2
	PERFORATED	A15	IP100KCA	1000	123	Ø6	1,2	158	TXNPC870	2
COMPOSITE	HEELPROOF SLOTTED BLACK	A15	PNH100KCAM	500	123	5	0,6	159	TXE860	2
	HEELPROOF SLOTTED GREY	A15	PNH100KCAM-GRIS	500	123	5	0,6	159	TXE860	2
	LONG. SLOTTED BLACK	A15	PNLH100KCAM	500	130	8	0,3	484	TXE860	2
	LONG. SLOTTED GREY	A15	PNLH100KCAM-GRIS	500	130	8	0,3	484	TXE860	2
	MESH	B125	PE100KCBM	500	123	14 x 12,5	0,5	553	TXE860	2

\* Available in stainless steel, consult design

## CLOSED END CAP

Code	
T100MVC	





Load Class  
up to C250  
EN-1433 Standard

# M150



ULMA Linear Drainage Channel type M150: External width 204 mm; Internal width 150 mm and overall height 80 mm to collect rainwater in 1 metre long units. Locking system consists of 2 screws per metre.

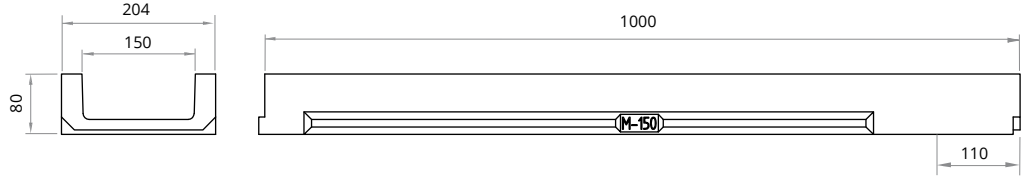

## CHANNEL

Code Channel	L mm	H mm	Width mm		Ø Outlet* mm		Hydraul. Section cm <sup>2</sup>	Pcs. pallet	Weight Kg	Qref l/s
			Ext.	Int.	Vert.	Hor.				
M150	1000	80	204	150	160	-	89	72	15,5	2,5

\* Vertical outlets on order

## GRATING

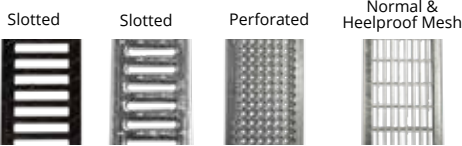

Material	Design	Load	Code	L mm	Width mm	Thickness mm	Opening mm	Weight Kg	Intake area cm <sup>2</sup> /ml	Code	Units ml
DUCTILE IRON	SLOTTED	B125	FNX150UCBM	500	200	6	13,75	4,0	683	TEF865	2
	SLOTTED	C250	FNX150UCCM	500	200	5	13,75	4,4	683	TEF865	2
GALVANISED STEEL	SLOTTED*	A15	GN150UCA	1000	200	3	8	3,4	392	(1) TNPC870	2
	PERFORATED	A15	GP150UCA	1000	200	3	Ø5	4,2	196	TNPC870	2
	MESH*	B125	GEX150UCB33	1000	200	2	30 x 30	5,0	1254	TEF860	2
	HEELPROOF MESH*	B125	GEHX150UCB	1000	200	2	30 x 10	6,2	1116	TEF860	2
STAINLESS STEEL	PERFORATED	A15	IP150UCA	1000	200	3	Ø5	4,4	196	TXNPC870	2

\* Available in stainless steel, consult design

## HOW TO FIX

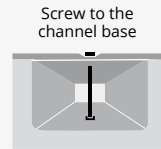

(1) Click. Without screws.

## CLOSED END CAP

Code	Image
T150MC	



Load Class  
up to C250  
EN-1433 Standard

# M150K

ULMA Linear Drainage Channel type M150K: External width 204 mm; Internal width 150 mm and overall height 100 mm to collect rainwater in 1 metre long units. Integrated galvanised steel\* edges for lateral protection. Locking system consists of 2 screws per metre.

\*Also available with stainless steel edge protection.

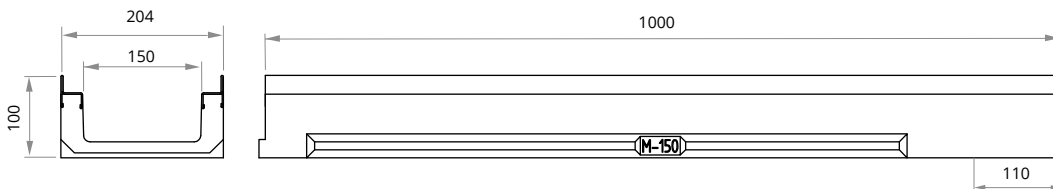

## CHANNEL

Code Channel	L mm	H mm	Width mm		Ø Outlet* mm		Hydraul. Section cm <sup>2</sup>	Pcs. pallet	Weight Kg	Qref l/s
			Ext.	Int.	Vert.	Hor.				
M150K	1000	100	204	150	160	-	89	60	18,2	2,5

\* Vertical outlets on order

## GRATING

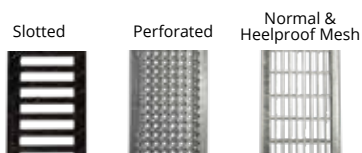

## HOW TO FIX

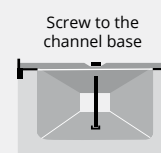

Material	Design	Load	Code	L mm	Width mm	Opening mm	Weight Kg	Intake area cm <sup>2</sup> /ml	Code	Units ml
DUCTILE IRON	SLOTTED	C250	FNX150KCCM	500	195	14	5,2	720	TEF880	2
GALVANISED STEEL	PERFORATED	A15	GP150KCA	1000	195	Ø5	4,1	196	TNPC890	2
	MESH	B125	GEX150KCB	1000	195	30 x 20	5,6	1413	TEF880	2
	HEELPROOF MESH*	B125	GEHX150KCB	1000	195	30 x 10	6,6	1133	TEF880	2
STAINLESS STEEL	PERFORATED	A15	IP150KCA	1000	195	Ø5	4,1	794	TXNPC890	2

\* Available in stainless steel, consult design

## CLOSED END CAP

Code	Image
T150MKC	



Load Class  
up to C250  
EN-1433 Standard

# M200



ULMA Linear Drainage Channel type M200: External width 260 mm; Internal width 200 mm and overall height 100 mm to collect rainwater in 1 metre long units. Locking system consists of 2 screws per metre.

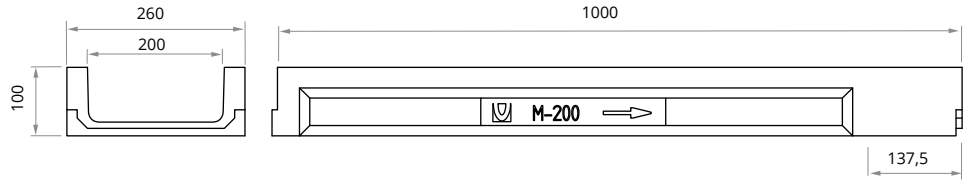

## CHANNEL

Code Channel	L mm	H mm	Width mm		Ø Outlet* mm		Hydraul. Section cm <sup>2</sup>	Pcs. pallet	Weight Kg	Qref l/s
			Ext.	Int.	Vert.	Hor.				
M200	1000	100	260	200	160	-	157	49	20,5	5,5

\* Vertical outlets on order

## GRATING

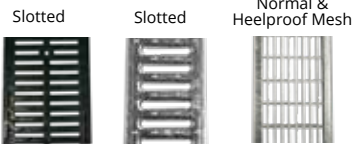

Material	Design	Load	Code	L mm	Width mm	Thickness mm	Opening mm	Weight Kg	Intake area cm <sup>2</sup> /ml
DUCTILE IRON	SLOTTED	C250	FNX200UCCM	500	250	6	10	6,7	610
GALVANISED STEEL	SLOTTED*	A15	GN200UCA	1000	250	3	8,5	5,2	418
	MESH*	B125	GEX200UCB33	1000	250	2,5	30 x 30	8,0	1634
	HEELPROOF MESH*	B125	GEHX200UCB	1000	250	2,5	30 x 10	9,5	1453

\* Available in stainless steel, consult design

## HOW TO FIX

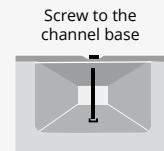

Code	Units ml
TEF880	2
TNPC890	2
TEF880	2
TEF880	2

## CLOSED END CAP

Code	Image
T200MC	



Load Class  
up to C250  
EN-1433 Standard

# M200K

ULMA Linear Drainage Channel type M200K: External width 260 mm; Internal width 200 mm and overall height 125 mm to collect rainwater in 1 metre long units. Integrated galvanised steel\* edges for lateral protection. Locking system consists of 2 screws per metre.



\*Also available with stainless steel edge protection.

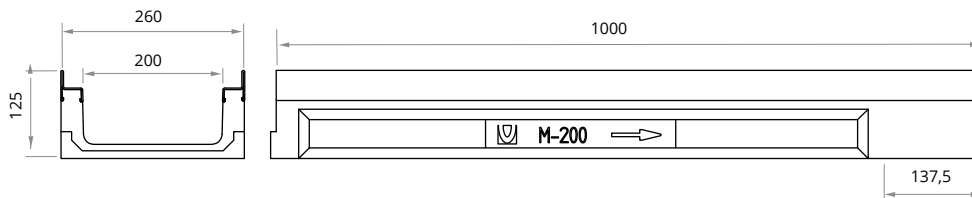

## CHANNEL

Code Channel	L mm	H mm	Width mm		Ø Outlet* mm		Hydraul. Section cm <sup>2</sup>	Pcs. pallet	Weight Kg	Qref l/s
			Ext.	Int.	Vert.	Hor.				
M200K	1000	125	260	200	160	-	157	40	27,2	5,5

\* Vertical outlets on order

## GRATING

Slotted



Mesh



## HOW TO FIX

Screw to the  
channel base

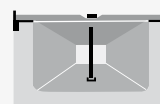

Material	Design	Load	Code	L mm	Width mm	Opening mm	Weight Kg	Intake area cm <sup>2</sup> /ml	Code	Units ml
									DUCTILE IRON	SLOTTED
GALVANISED STEEL	MESH*	B125	GEX200KCB	1000	250	30 x 20	8,0	1846	TEF8100	2

\* Available in stainless steel, consult design

## CLOSED END CAP

Code	
T200MKC	



Load Class  
up to C250  
EN-1433 Standard

# M300K



ULMA Linear Drainage Channel type M300K: External width 362 mm; Internal width 300 mm and overall height 150 mm to collect rainwater in 1 metre long units. Integrated galvanised steel edges for lateral protection. Locking system consists of locking bar CS300 and screws.

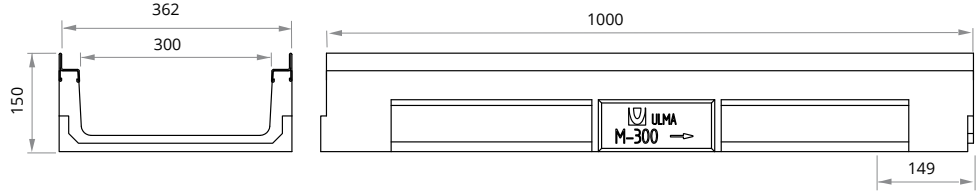

## CHANNEL

Code Channel	L mm	H mm	Width mm		Ø Outlet* mm		Hydraul. Section cm <sup>2</sup>	Pcs. pallet	Weight Kg	Qref l/s
			Ext.	Int.	Vert.	Hor.				
M300K	1000	150	362	300	200	-	294	24	33,2	11,8

\* Vertical outlets on order

## GRATING

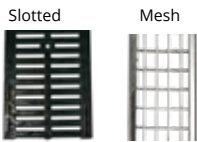

Material	Design	Load	Code	L mm	Width mm	Opening mm	Weight Kg	Intake area cm <sup>2</sup> /ml
DUCTILE IRON	SLOTTED	C250	FNX300KCCM	500	351	14	15,3	1368
GALVANISED STEEL	MESH*	B125	GEX300KCB	1000	351	30 x 20	13,2	2672

\* Available in stainless steel, consult design

## HOW TO FIX

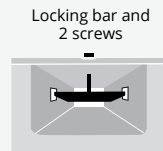

Code	Units ml
TEF1080 + CS300	2 + 2
TEF1080 + CS300	2 + 2

## CLOSED END CAP

Code
T300MKC



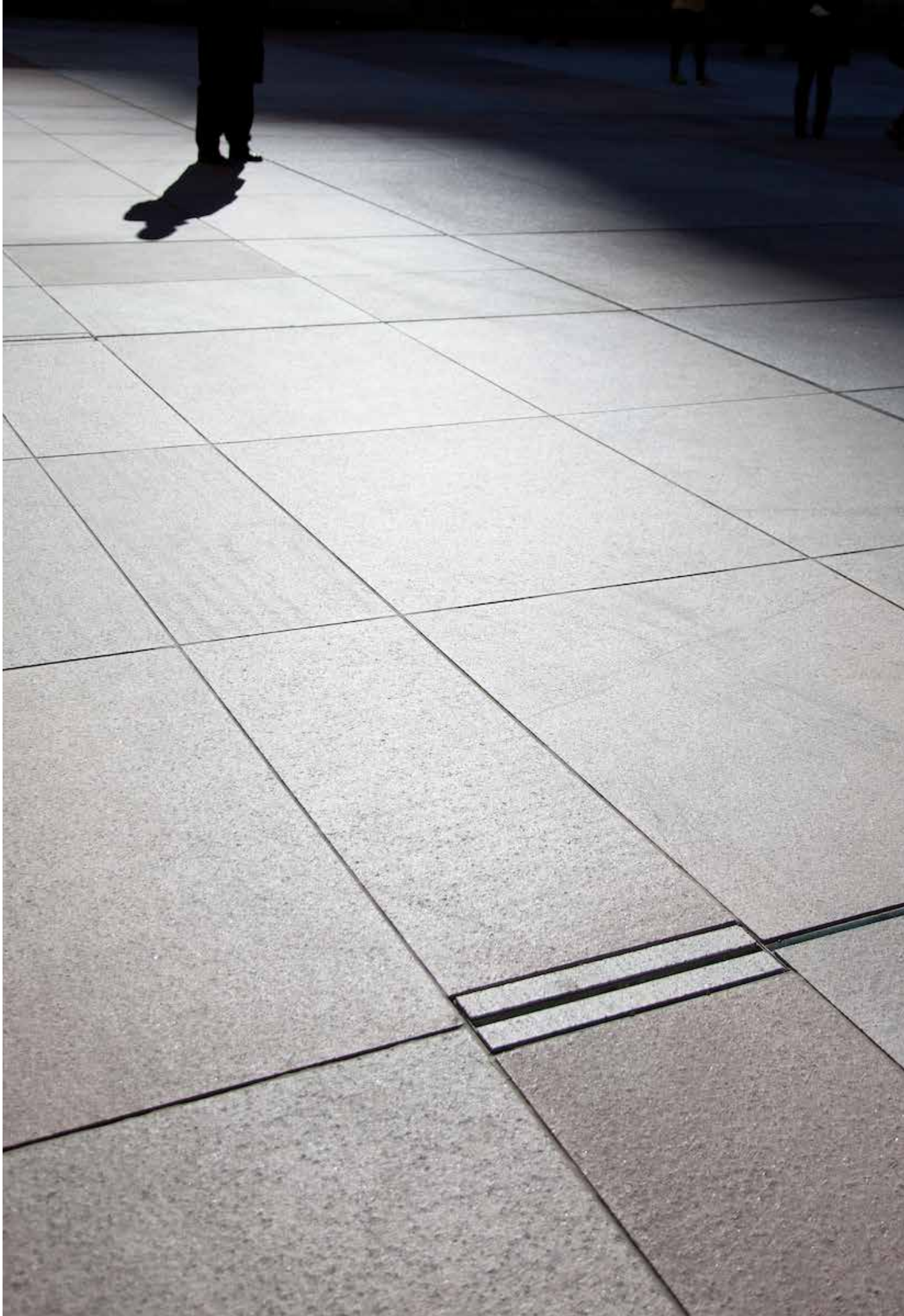

# URBAN

## SYSTEM

### Housing estates, squares, pedestrian access to car parks...

Channels without slope, with built-in slope, continuous and/or cascaded. A15, B125 and C250 class gratings.

The continuous and/or cascaded slope arrangement makes it possible to install long stretches of channelling between evacuation points.

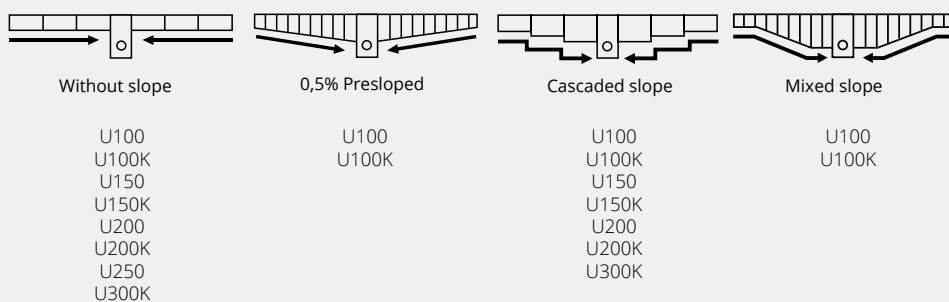
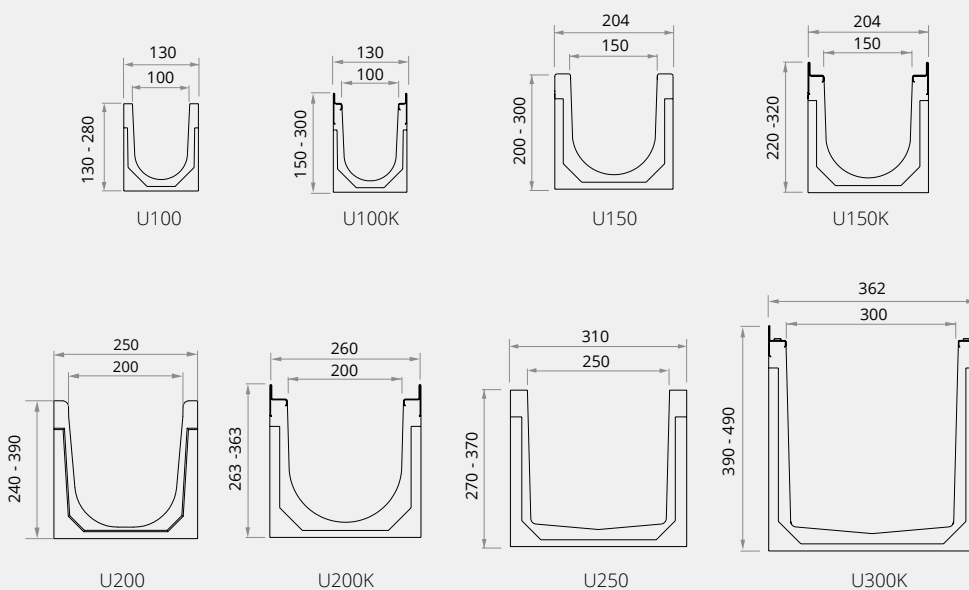



Load Class  
up to C250  
EN-1433 Standard

# U100



ULMA Linear Drainage Channel type U100: External width 130 mm; Internal width 100 mm; Available with overall heights between 130 and 280 mm for 0,5% presloped channels and between 130 and 280 mm for cascaded slope, to collect rainwater in 1 metre long units. Locking system consists of locking bar CS100 and screws.

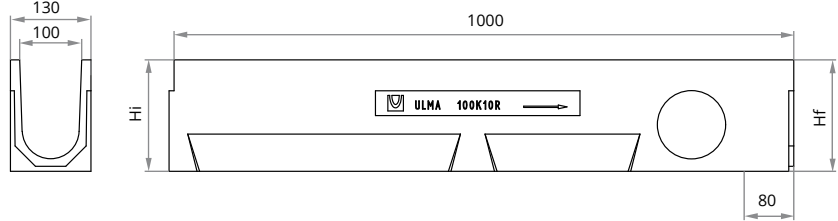

## CHANNELS

Code Channel	L mm	H mm		Width mm		Ø Outlet* mm		Hydraul. Section cm <sup>2</sup>	Pcs. pallet	Weight Kg	Qref l/s
		h	H	Z	X	Vert.	Hor.				
U100.00R	1000	130	130	130	100	110	-	97	90	13,3	3,5
U100.01	1000	130	135	130	100	-	-	97	90	13,9	-
U100.02	1000	135	140	130	100	-	-	101	90	14,1	-
U100.03	1000	140	145	130	100	-	-	106	78	14,8	-
U100.04	1000	145	150	130	100	-	-	111	78	14,6	-
U100.05	1000	150	155	130	100	-	-	116	78	15,1	-
U100.05R	1000	155	155	130	100	110	-	120	78	15,3	5,0
U100.06	1000	155	160	130	100	-	-	120	65	15,2	-
U100.07	1000	160	165	130	100	-	-	125	65	15,9	-
U100.08	1000	165	170	130	100	-	-	130	65	16,6	-
U100.09	1000	170	175	130	100	-	-	135	65	17,7	-
U100.10	1000	175	180	130	100	-	-	140	65	17,2	-
U100.10R	1000	180	180	130	100	110	110	145	65	18,4	6,7
U100.11	1000	180	185	130	100	-	-	145	65	17,3	-
U100.12	1000	185	190	130	100	-	-	150	65	18,1	-
U100.13	1000	190	195	130	100	-	-	155	65	18,2	-
U100.14	1000	195	200	130	100	-	-	159	65	18,0	-
U100.15	1000	200	205	130	100	-	-	164	65	18,3	-
U100.15R	1000	205	205	130	100	110	110	169	65	19,7	8,5
U100.16	1000	205	210	130	100	-	-	169	65	19,0	-
U100.17	1000	210	215	130	100	-	-	174	65	19,5	-
U100.18	1000	215	220	130	100	-	-	178	52	20,2	-
U100.19	1000	220	225	130	100	-	-	183	52	19,9	-
U100.20	1000	225	230	130	100	-	-	188	52	21,0	-
U100.20R	1000	230	230	130	100	110	110	193	52	22,2	10,5
U100.25R	1000	255	255	130	100	110	110	240	52	22,9	12,7
U100.30R	1000	280	280	130	100	110	110	288	52	24,8	14,9

\* Vert. and horiz. outlets on order .

## SLOPE DESIGNS

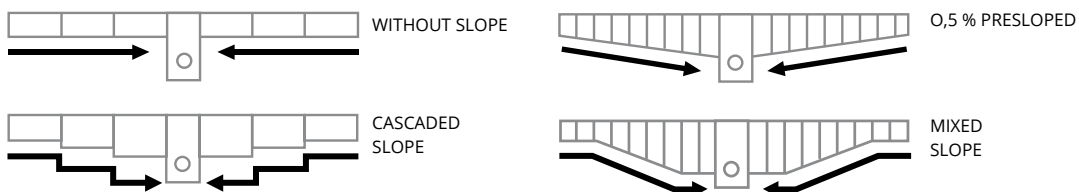

# U100

## GRATINGS

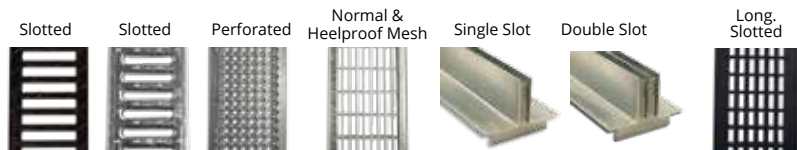

Material	Design	Load	Code	L mm	Width mm	Thickness mm	Opening mm	Weight Kg	Intake area cm <sup>2</sup> /ml
DUCTILE IRON	SLOTTED	B125	FNX100UCBM	500	130	6	14,9	2,1	530
	SLOTTED	C250	FNX100UCCM	500	130	6	13	2,7	435
GALVANISED STEEL	SLOTTED	A15	GN100UCA	1000	130	3	9	1,6	268
	PERFORATED	A15	GP100UCA	1000	130	3	Ø6	1,4	159
	MESH*	B125	GEX100UCB33	1000	130	2	30 x 30	3,2	837
	HEELPROOF MESH*	B125	GEHX100UCB	1000	130	2	30 x 10	3,9	739
	SLOT*	C250	GR100UOC	1000	130	70	15	4,8	150
	DOUBLE SLOT*	C250	GDR100UOC	1000	130	70	2 x 12	5,5	240
STAINLESS STEEL	SLOTTED	A15	IN100UCA	1000	130	3	7	1,5	218
	PERFORATED	A15	IP100UCA	1000	130	3	Ø6	1,7	159
COMPOSITE	LONG. SLOTTED BLACK	A15	PNLH100UCAM	500	130	3	8	0,3	367
	LONG. SLOTTED GREY	A15	PNLH100UCAM GRIS	500	130	3	8	0,3	367

\* Available in stainless steel, consult design

## HOW TO FIX

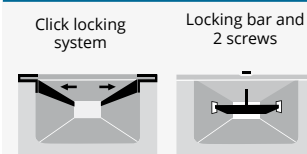

Code	Units ml
TEF840 + CS100	2 + 2
TEF840 + CS100	2 + 2
(1) TNPC850 + CS100	2 + 2
TNPC850 + CS100	2 + 2
TEF840 + CS100	2 + 2
(2)	(2)
(2)	(2)
TXNPC850 + CS100INOX	2 + 2
TXNPC850 + CS100INOX	2 + 2
(1) TXE840 + CS100INOX	2 + 2
(1) TXE840 + CS100INOX	2 + 2

(1) Click. Without screws.  
(2) Supported

## SUMP UNITS

Code	L mm	H mm	Width mm	Lateral outlets Ø mm	Front outlet Ø mm	Sump units	Weight Kg
AU100	500	542	130	110/160	90	1	29,4

## BUCKET

Code
CU100

## OPEN END CAP

Canal	Code	Ø mm
U100.00R	T100U00A	110
U100.05R	T100U05A	110
U100.10R	T100U10A	110
U100.15R	T100U15A	110
U100.20R	T100U20A	110
U100.25R	T100U25A	110
U100.30R	T100U30A	110

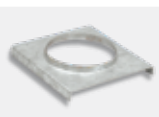

## CLOSED END CAP

Code
T100U00C
T100U05C
T100U10C
T100U15C
T100U20C
T100U25C
T100U30C

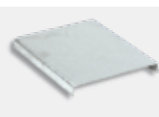

## STEP UNITS

Code
CEU100



To install in the changes of height with cascaded slope.



Load Class  
up to C250  
EN-1433 Standard

# U100K

ULMA Linear Drainage Channel type U100K: External width 130 mm; Internal width 100 mm; Available with overall heights between 150 mm and 300 mm for 0,5% presloped channels and between 150 and 300 mm for cascaded slope, to collect rainwater in 1 metre long units; Integrated galvanised steel\* edges for lateral protection. Locking system consists of CS100 locking bar and screws.

\*Also available with stainless steel edge protection.

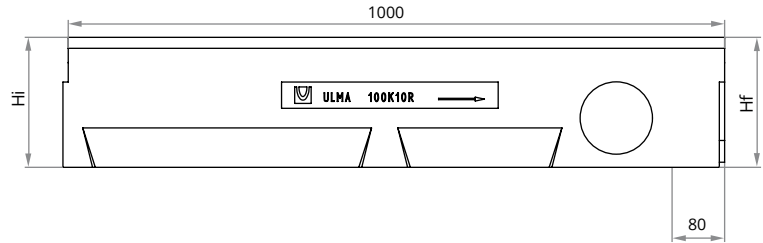
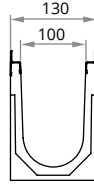

## CHANNELS

Code Channel	L mm	H mm		Width mm		Ø Outlet* mm		Hydraul. Section cm <sup>2</sup>	Pcs. x pallet	Weight Kg	Qref l/s
		h	H	Z	X	Vert.	Hor.				
U100K.00R	1000	150	150	130	100	110	-	97	90	14,0	3,5
U100K.01	1000	150	155	130	100	-	-	97	90	14,8	-
U100K.02	1000	155	160	130	100	-	-	101	90	15,2	-
U100K.03	1000	160	165	130	100	-	-	106	78	15,8	-
U100K.04	1000	165	170	130	100	-	-	111	78	15,7	-
U100K.05	1000	170	175	130	100	-	-	116	78	16,1	-
U100K.05R	1000	175	175	130	100	110	-	120	78	16,4	5,0
U100K.06	1000	175	180	130	100	-	-	120	65	16,6	-
U100K.07	1000	180	185	130	100	-	-	125	65	17,0	-
U100K.08	1000	185	190	130	100	-	-	130	65	17,8	-
U100K.09	1000	190	195	130	100	-	-	135	65	18,1	-
U100K.10	1000	195	200	130	100	-	-	140	65	17,9	-
U100K.10R	1000	200	200	130	100	110	110	145	65	18,0	6,7
U100K.11	1000	200	205	130	100	-	-	145	65	18,5	-
U100K.12	1000	205	210	130	100	-	-	150	65	18,8	-
U100K.13	1000	210	215	130	100	-	-	155	65	18,9	-
U100K.14	1000	215	220	130	100	-	-	159	65	19,3	-
U100K.15	1000	220	225	130	100	-	-	164	65	19,8	-
U100K.15R	1000	225	225	130	100	110	110	169	65	19,8	8,5
U100K.16	1000	225	230	130	100	-	-	169	65	19,9	-
U100K.17	1000	230	235	130	100	-	-	174	65	20,6	-
U100K.18	1000	235	240	130	100	-	-	178	52	21,1	-
U100K.19	1000	240	245	130	100	-	-	183	52	21,3	-
U100K.20	1000	245	250	130	100	-	-	188	52	22,1	-
U100K.20R	1000	250	250	130	100	110	110	193	52	22,3	10,5
U100K.25R	1000	275	275	130	100	110	110	240	52	23,0	12,7
U100K.30R	1000	300	300	130	100	110	110	288	52	26,1	14,9

\*Vert. and horiz. outlets on order.

## SLOPE DESIGNS

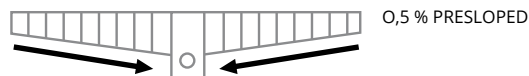
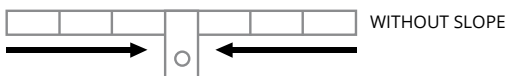

# U100K

## GRATINGS

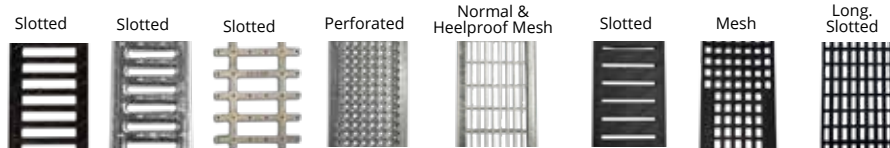

## HOW TO FIX

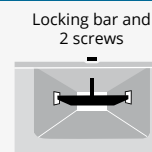

Material	Design	Load	Code	L mm	Width mm	Opening mm	Weight Kg	Intake area cm <sup>2</sup> /ml	Code	Units ml
DUCTILE IRON	SLOTTED	B125	FNX100KCBM	500	123	14	2,7	476	TEF860 + CS100	2 + 2
	SLOTTED	C250	FNX100KCCM	500	123	14	2,9	486	TEF860 + CS100	2 + 2
	HEELPROOF SLOTTED	C250	FNHX100KCCM	500	123	5	3,7	174	TEF860 + CS100	2 + 2
DUCTILE IRON STAINLESS	SLOTTED	D400	FIN100KCDM	500	123	19,9	3,5	695	TXE860 + CS100INOX	2 + 2
GALVANISED STEEL	PERFORATED	A15	GP100KCA	1000	123	Ø6	1,1	158	TNPC870 + CS100	2 + 2
	SLOTTED	A15	GN100KCA	1000	123	9	1,6	282	TNPC870 + CS100	2 + 2
	MESH	B125	GEX100KCB	1000	123	30 x 20	3,3	823	TEF860 + CS100	2 + 2
	HEELPROOF MESH *	B125	GEHX100KCB	1000	123	30 x 10	4,0	743	TEF860 + CS100	2 + 2
STAINLESS STEEL	SLOTTED	A15	IN100KCA	1000	123	7	1,4	216	TXNPC870 + CS100INOX	2 + 2
	PERFORATED	A15	IP100KCA	1000	123	Ø6	1,2	158	TXNPC870 + CS100INOX	2 + 2
COMPOSITE	HEELPROOF SLOTTED BLACK	A15	PNH100KCAM	500	123	5	0,6	159	TXE860 + CS100INOX	2 + 2
	HEELPROOF SLOTTED GREY	A15	PNH100KCAM-GRIS	500	123	5	0,6	159	TXE860 + CS100INOX	2 + 2
	LONG SLOTTED BLACK	A15	PNLH100KCAM	500	130	8	0,3	484	TXE860 + CS100INOX	2 + 2
	LONG SLOTTED GREY	A15	PNLH100KCAM-GRIS	500	130	8	0,3	484	TXE860 + CS100INOX	2 + 2
	MESH	B125	PE100KCBM	500	123	14 x 12,5	0,5	553	TXE850 + CS100INOX	2 + 2

\* Available in stainless steel, consult design

## SUMP UNITS

Code	L mm	H mm	Width mm	Lateral outlets Ø mm	Front outlet Ø mm	Sump units	Weight Kg
AK100	500	560	130	110/160	90	1	30,2

## BUCKET

Code
CU100

## STEP UNITS

Code
CEU100

To install in the changes of height with cascaded slope.

## OPEN END CAP

Canal	Code	Ø mm
U100K00R	T100K00A	110
U100K05R	T100K05A	110
U100K10R	T100K10A	110
U100K15R	T100K15A	110
U100K20R	T100K20A	110
U100K25R	T100K25A	110
U100K30R	T100K30A	110

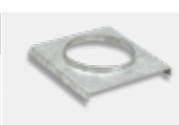

## CLOSED END CAP

Code
T100K00C
T100K05C
T100K10C
T100K15C
T100K20C
T100K25C
T100K30C

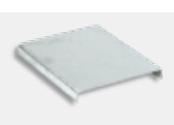

Load Class  
up to C250  
EN-1433 Standard

# U150



ULMA Linear Drainage Channel type U150: External width 204 mm; Internal width 150 mm; Available with overall heights between 200 mm and 300 mm. Suitable for cascaded type slope, to collect rainwater in 1 metre long units. Locking system consists of locking bar CS150 and screws.

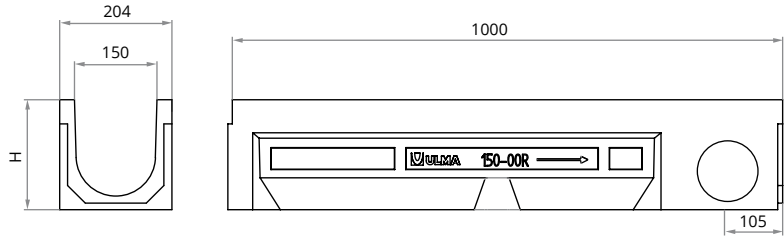

## CHANNELS

Code Channel	L mm	H mm	Width mm		Ø Outlet* mm		Hydraul. Section cm <sup>2</sup>	Pcs. pallet	Weight Kg	Qref l/s
			Ext.	Int.	Vert.	Hor.				
U150.00R	1000	200	204	150	160	110	230	45	25,5	11,8
U150.10R	1000	250	204	150	160	110	305	36	31,3	18,1
U150.20R	1000	300	204	150	160	110	380	27	36,0	25,3

\* Vert. and horiz. outlets on order.

## GRATINGS

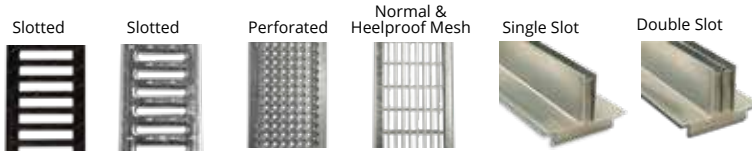

Material	Design	Load	Code	L mm	Width mm	Thickness mm	Opening mm	Weight Kg	Intake area cm <sup>2</sup> /ml
DUCTILE IRON	SLOTTED	B125	FNX150UCBM	500	200	200	200	4,0	683
	SLOTTED	C250	FNX150UCCM	500	200	5	13,75	4,4	683
GALVANISED STEEL	SLOTTED*	A15	GN150UCA	1000	200	3	8	3,4	392
	PERFORATED	A15	GP150UCA	1000	200	3	Ø5	4,2	196
	MESH*	B125	GEX150UCB33	1000	200	2	30 x 30	5,0	1254
	HEELPROOF MESH	B125	GEHX150UCB	1000	200	2	30 x 10	6,2	1116
	SLOT*	C250	GR150UOC	1000	200	70	15	6,2	150
	DOUBLE SLOT*	C250	GDR150UOC	1000	200	70	2 x 12	7,0	240
STAINLESS STEEL	PERFORATED	A15	IP150UCA	1000	200	3	Ø5	4,4	196

\* Available in stainless steel, consult design

## HOW TO FIX

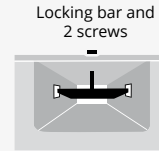

Code	Units ml
TEF860 + CS150	2 + 2
TEF860 + CS150	2 + 2
(1) TNPC870 + CS150	2 + 2
TNPC870 + CS150	2 + 2
TEF860 + CS150	2 + 2
TEF860 + CS150	2 + 2
(2)	(2)
(2)	(2)
TXNPC870 + CS150INOX	2 + 2

(1) Click. Without screws.  
(2) Supported

## SUMP UNITS

Code	L mm	H mm	Width mm	Lateral outlets Ø mm	Front outlet Ø mm	Sump units	Weight Kg
AU150	500	328	204	160	110	1	21,9
AU150S + A150B	500	633*	204	160	110	2	47,0

\* The sump unit can be higher incorporating an intermediate unit.

## BUCKET

Code**
C150

\*\* Only applicable if 2 sump units are installed.

## OPEN END CAP

Canal	Code	Ø mm
U150.00R	T150U00A	160
U150.10R	T150U10A	160
U150.20R	T150U20A	160

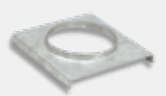

## CLOSED END CAP

Code
T150U00C
T150U10C
T150U20C



## STEP UNITS

Code
CE150



To install in the changes of height with cascaded slope.

## SLOPE DESIGNS



**Load Class**  
up to C250  
EN-1433 Standard

# U150K



ULMA Linear Drainage Channel type U150K: External width 204 mm; Internal width 150 mm; Suitable for cascade type slope and available with overall heights between 220 mm and 320 mm to collect rainwater in 1 metre long units; Integrated galvanised steel\* edges for lateral protection. Locking system consists of CS150 locking bar and screws.



\*Also available with stainless steel edge protection.

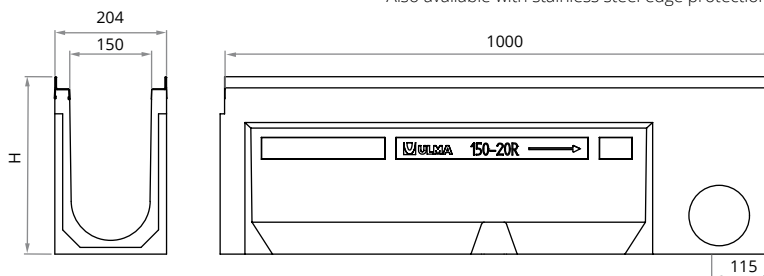

## CHANNELS

Code Channel	L mm	H mm	Width mm		Ø Outlet* mm		Hydraul. Section cm <sup>2</sup>	Pcs. pallet	Weight Kg	Qref l/s
			Ext.	Int.	Vert.	Hor.				
U150K00R	1000	220	204	150	160	110	230	45	28,4	11,8
U150K10R	1000	270	204	150	160	110	305	36	35,1	18,1
U150K20R	1000	320	204	150	160	-	380	27	38,6	25,3

\* Vert. and horiz. outlets on order.

## GRATINGS

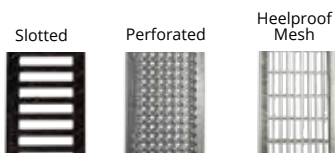

Material	Design	Load	Code	L mm	Width mm	Opening mm	Weight Kg	Intake area cm <sup>2</sup> /ml
DUCTILE IRON	SLOTTED	C250	FNX150KCCM	500	195	14	5,2	720
	PERFORATED	A15	GP150KCA	1000	195	Ø5	4,1	196
GALVANISED STEEL	MESH	B125	GEX150KCB	1000	195	30 x 20	5,6	1413
	HEELPROOF MESH *	B125	GEHX150KCB	1000	195	30 x 10	6,6	1133
STAINLESS STEEL	PERFORATED	A15	IP150KCA	1000	195	Ø5	4,1	196

\* Available in stainless steel, consult design

## HOW TO FIX

Locking bar and 2 screws

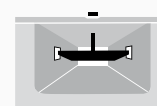

Code	Units ml
TEF880 + CS150	2 + 2
TNPC890 + CS150	2 + 2
TEF880 + CS150	2 + 2
TEF880 + CS150	2 + 2
TXNPC890 + CS150I-NOX	2 + 2

## SUMP UNITS

Code	L mm	H mm	Width mm	Lateral outlets Ø mm	Front outlet Ø mm	Sump units	Weight Kg
AK150	500	350	204	160	110	1	23,2
AK150S + A150B	500	655*	204	160	110	2	47,0

\* The sump unit can be higher incorporating an intermediate unit.

## BUCKET

Code**
C150

\*\* Only applicable if 2 sump units are installed.

## OPEN END CAP

Canal	Code	Ø mm
U150K00R	T150K00A	160
U150K10R	T150K10A	160
U150K20R	T150K20A	160

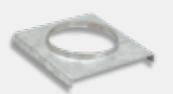

## CLOSED END CAP

Code
T150K00C
T150K10C
T150K20C

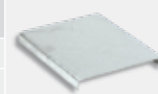

## STEP UNITS

Code
CE150



To install in the changes of height with cascaded slope.

## SLOPE DESIGNS



Load Class  
up to C250  
EN-1433 Standard

# U200



ULMA Linear Drainage Channel type U200: External width 260 mm; Internal width 200 mm; Available with overall heights between 240 mm and 390 mm. Suitable for cascaded type slope to collect rainwater in 1 metre long units. Locking system consists of locking bar CS200 and screws.

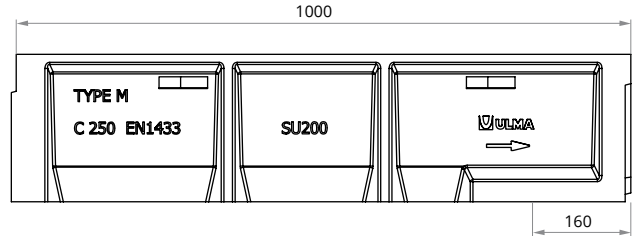
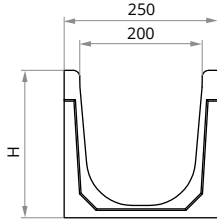

## CHANNELS

Code Channel	L mm	H mm	Width mm		Ø Outlet* mm		Hydraul. Section cm²	Pcs. pallet	Weight Kg	Qref l/s
			Ext.	Int.	Vert.	Hor.				
SU200.00R	1000	240	250	200	200	-	385	28	31,9	22,70
SU200.10R	1000	290	250	200	200	-	465	28	35,8	30,46
SU200.20R	1000	340	250	200	200	-	540	21	42,1	38,67
SU200.30R	1000	390	250	200	200	-	620	21	47,6	48,19

\* Vertical outlets on order

## GRATINGS

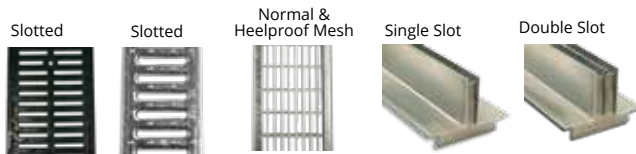

Material	Design	Load	Code	L mm	Width mm	Thickness mm	Opening mm	Weight Kg	Intake area cm²/ml
DUCTILE IRON	SLOTTED	C250	FNX200UCCM	500	250	6	10	6,7	610
	SLOTTED*	A15	GN200UCA	1000	250	4	8,5	5,2	418
GALVANISED STEEL	MESH*	B125	GEX200UCB33	1000	250	2,5	30 x 30	8,0	1634
	HEELPROOF MESH*	B125	GEHX200UCB	1000	250	2,2	30 x 10	9,5	1453
	SLOT*	C250	GR200UOC	1000	250	70	15	7,9	150
	DOUBLE SLOT*	C250	GDR200UOC	1000	250	70	2 x 12	10	240

\* Available in stainless steel, consult design

## SUMP UNITS

Code	L mm	H mm	Width mm	Lateral outlets Ø mm	Front outlet Ø mm	Sump units	Weight Kg
AU200*	500	338	260	160/200	-	1	23,2
AU200S + A200B*	500	680**	260	160/200	-	2	48,3

\* Sump units available only up to height 340mm - SU200.20R

\*\* The sump unit can be higher incorporating an intermediate unit.

## HOW TO FIX

Locking bar and 2 screws



Code	Units ml
TEF1060 + CS200	2 + 2
TEF1060 + CS200	2 + 2
TEF1060 + CS200	2 + 2
TEF1060 + CS200	2 + 2
(1)	(1)
(1)	(1)

(1) Click. Without screws.

## BUCKET



\* Only applicable if 2 sump units are installed.

## OPEN END CAP

Canal	Code	Ø mm
SU200.00R	T200SU00A	200
SU200.10R	T200SU10A	200
SU200.20R	T200SU20A	200
SU200.30R	T200SU30A	200

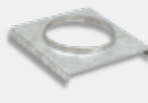

## CLOSED END CAP

Code
T200SU00C
T200SU10C
T200SU20C
T200SU30C

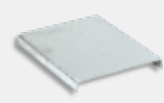

## STEP UNITS

Code
CE200



To install in the changes of height with cascaded slope.

## SLOPE DESIGNS



**Load Class**  
up to C250  
EN-1433 Standard

# U200K

ULMA Linear Drainage Channel type U200K: External width 260 mm; Internal width 200 mm; Suitable for cascade type slope and available with overall heights between 263 mm and 363 mm to collect rainwater in 1 metre long units; Integrated galvanised steel\* edges for lateral protection. Locking system consists of CS200 locking bar and screws.



\*Also available with stainless steel edge protection.

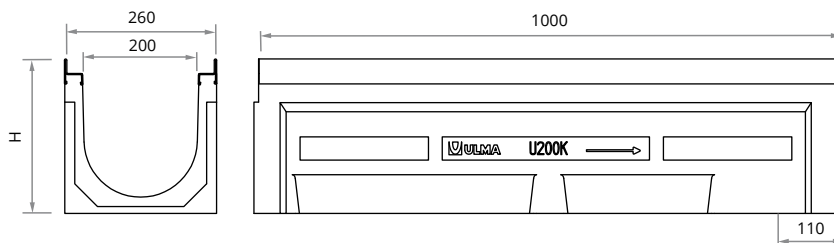

## CHANNELS

Code Channel	L mm	H mm	Width mm		Ø Outlet* mm		Hydraul. Section cm <sup>2</sup>	Pcs. pallet	Weight Kg	Qref l/s
			Ext.	Int.	Vert.	Hor.				
U200K00R	1000	263	260	200	160	-	374	28	42,5	21,4
U200K10R	1000	313	260	200	160	160	473	21	48,2	30,7
U200K20R	1000	363	260	200	160	-	571	21	53,5	41,3

\* Vert. and horiz. outlets on order.

## GRATINGS

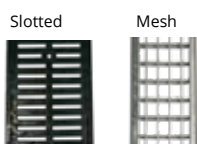

Material	Design	Load	Code	L mm	Width mm	Opening mm	Weight Kg	Intake area cm <sup>2</sup> /ml
DUCTILE IRON	SLOTTED	C250	FNX200KCCM	500	250	14	7,2	919
GALVANISED STEEL	MESH*	B125	GEX200KCB	1000	250	30 x 20	8,0	1846

\* Available in stainless steel, consult design

## HOW TO FIX

Locking bar and 2 screws

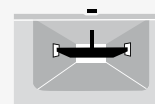

Code	Units ml
TEF1070 + CS200	2 + 2
TEF1070 + CS200	2 + 2

## SUMP UNITS

Code	L mm	H mm	Width mm	Lateral outlets Ø mm	Front outlet Ø mm	Sump units	Weight Kg
AK200	500	363	260	160/200	-	1	34,3
AK2005 + A200B	500	705*	260	160/200	-	2	55,4

\* The sump unit can be higher incorporating an intermediate unit.

## BUCKET

Code**
C200

\*\* Only applicable if 2 sump units are installed.

## OPEN END CAP

Canal	Code	Ø mm
U200K00R	T200K00A	200
U200K10R	T200K10A	200
U200K20R	T200K20A	200

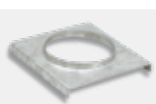

## CLOSED END CAP

Code
T200K00C
T200K10C
T200K20C



## STEP UNITS

Code
CE200



To install in the changes of height with cascaded slope.

## SLOPE DESIGNS

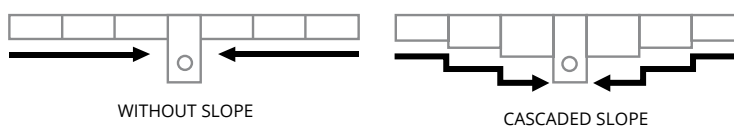



Load Class  
up to C250  
EN-1433 Standard

# U250



ULMA Linear Drainage Channel type U250: External width 310 mm; Internal width 250 mm, and overall height between 270 and 370 mm, to collect rainwater in 1 metre long units. Locking system consists of locking bar CS250 and screws.

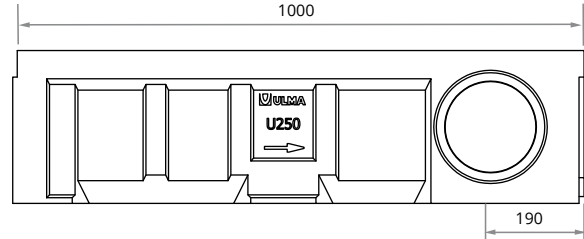
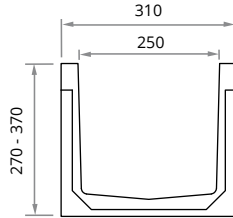

## CHANNELS

Code Channel	L mm	H mm	Width mm		Ø Outlet* mm		Hydraul. Section cm²	Pcs. pallet	Weight Kg	Qref l/s
			Ext.	Int.	Vert.	Hor.				
U250.00R	1000	270	310	250	250	200	580	28	39,7	38,6
U250.10R	1000	320	310	250	250	200	706	21	45,5	51,5
U250.20R	1000	370	310	250	250	250	828	21	51,3	65,7

\* Vert. and horiz. outlets on order

## GRATINGS

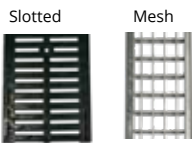

Material	Design	Load	Code	L mm	Width mm	Thickness mm	Opening mm	Weight Kg	Intake area cm²/ml
DUCTILE IRON	SLOTTED	B125	FNX250UCBM	500	300	6	13,2	39,7	1049
	SLOTTED	C250	FNX250UCCM	500	300	6	14	45,5	1004
GALVANISED STEEL	MESH*	B125	GEX250UCB	1000	300	3	30 x 20	12,3	1993

\* Available in stainless steel, consult design

## HOW TO FIX

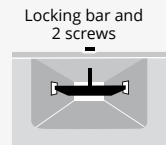

Code	Units ml
TEF1050 + CS250	2 + 2
TEF1050 + CS250	2 + 2
TEF1050 + CS250	2 + 2

## SUMP UNITS

Code	L mm	H mm	Width mm	Lateral outlets Ø mm	Front outlet Ø mm	Sump units	Weight Kg
AU250	500	375	310	160/200	-	1	36,5
AU250S+ A250B	500	725*	310	160/200	-	2	62,7

\* The sump unit can be higher incorporating an intermediate unit.

## BUCKET

Code**
C250

\*\* Only applicable if 2 sump units are installed.

## OPEN END CAP

Canal	Code	Ø mm
U250.00R	T250U00A	200
U250.10R	T250U10A	200
U250.20R	T250U20A	200

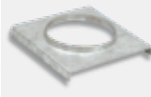

## CLOSED END CAP

Code
T250U00C
T250U10C
T250U20C



## STEP UNITS

Code
CE250



To install in the changes of height with cascaded slope.

## SLOPE DESIGNS

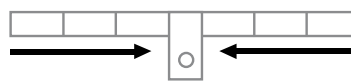

WITHOUT SLOPE

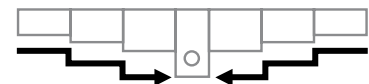

CASCADED SLOPE

**Load Class**  
up to **C250**  
EN-1433 Standard

# U300K

ULMA Linear Drainage Channel type U300K: External width 362 mm; Internal width 300 mm and available with overall heights between 390 mm and 490 mm; Suitable for cascade type slope to collect rainwater in 1 metre long units; Integrated galvanised steel\* edges for lateral protection. Locking system consists of CS300 locking bar and screws.



\*Also available with stainless steel edge protection.

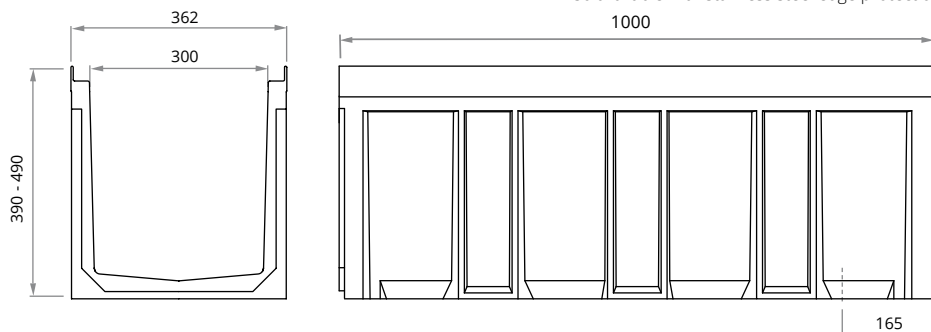

## CHANNELS

Code Channel	L mm	H mm	Width mm		Ø Outlet* mm		Hydraul. Section cm <sup>2</sup>	Pcs. pallet	Weight Kg	Qref l/s
			Ext.	Int.	Vert.	Hor.				
U300K00R	1000	390	362	300	200	-	975	15	61,7	75,9
U300K10R	1000	440	362	300	200	-	1110	10	70,2	94,2
U300K20R	1000	490	362	300	200	-	1250	10	75,7	113,9

\* Vertical outlets on order

## GRATINGS

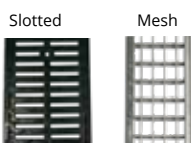

Material	Design	Load	Code	L mm	Width mm	Opening mm	Weight Kg	Intake area cm <sup>2</sup> /ml
DUCTILE IRON	SLOTTED	C250	FNX300KCCM	500	351	14	15,3	1368
GALVANISED STEEL	MESH	B125	GEX300KCB	1000	351	30 x 20	13,2	2672

## HOW TO FIX

Locking bar and 2 screws



Code	Units ml
TEF1090 + CS300	2 + 2
TEF1090 + CS300	2 + 2

## SUMP UNITS

Code	L mm	H mm	Width mm	Lateral outlets Ø mm	Front outlet Ø mm	Sump units	Weight Kg
AK300*	500	390	362	200	-	1	42,7
AK300S+ A300B*	500	730**	362	200	-	2	70,9

\* Available up to a height of 390mm

\*\*The sump unit can be higher incorporating an intermediate unit.

## BUCKET

Code**
C250

\*\* Only applicable if 2 sump units are installed.

## OPEN END CAP

Canal	Code	Ø mm
U300K00R	T300K00A	300
U300K10R	T300K10A	300
U300K20R	T300K20A	300

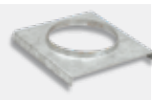

## CLOSED END CAP

Code
T300K00C
T300K10C
T300K20C



## STEP UNITS

Code
CE300



To install in the changes of height with cascaded slope.

## SLOPE DESIGNS



WITHOUT SLOPE

CASCADED SLOPE

# SUMP UNITS

## AU100

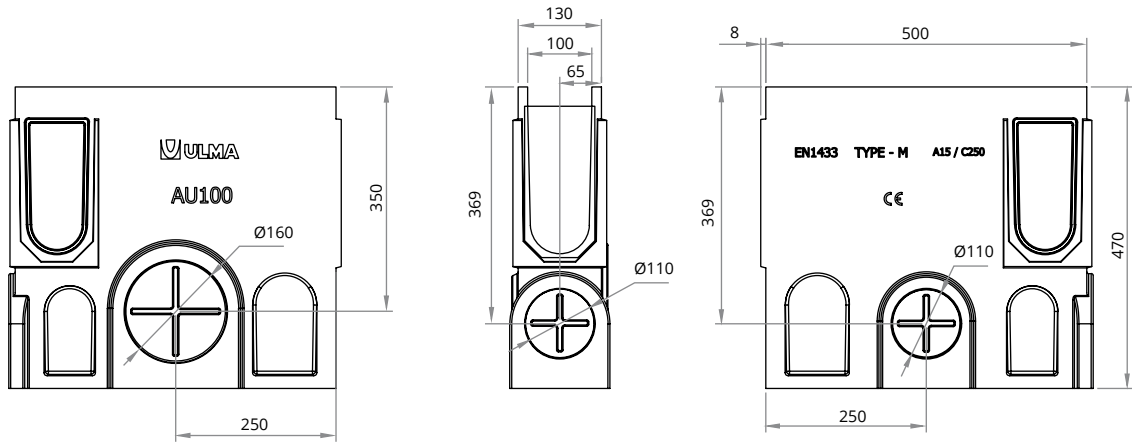

## AK100

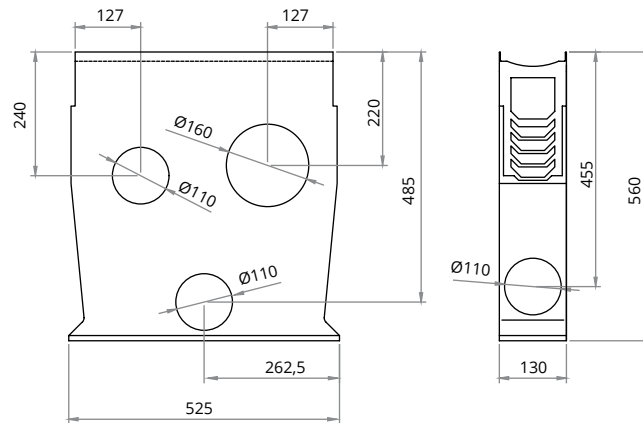

## AK150S + A150I + A150B / AU150S + A150I + A150B

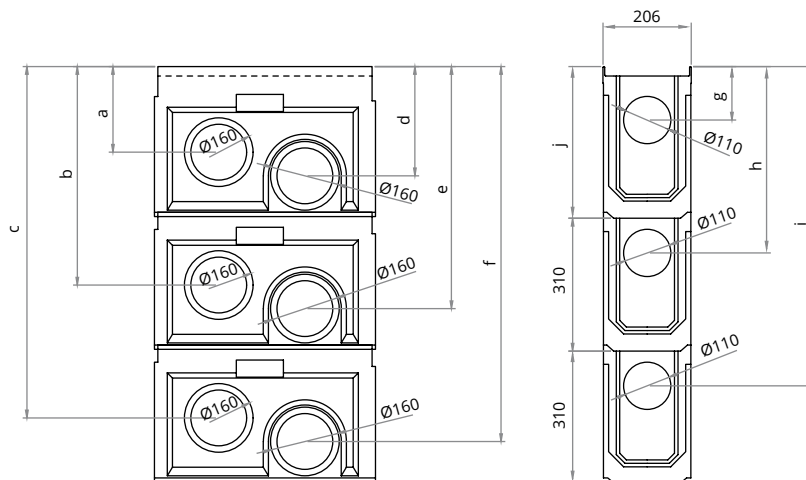

Code Channel	a mm	b mm	c mm	d mm	e mm	f mm	g mm	h mm	i mm	j mm
AK150S+A150I+A150B	200	505	815	255	560	870	125	430	740	345
AU150S+A150I+A150B	170	480	790	225	535	845	95	405	715	320

# SUMP UNITS

AK200S + A200I + A200B / AU200S + A200I + A200B

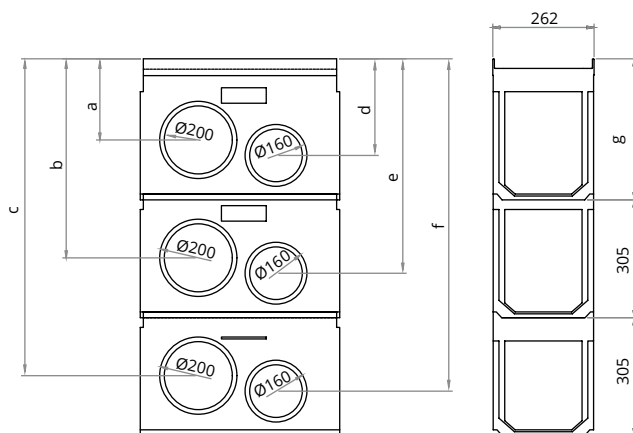

Code Channel	a mm	b mm	c mm	d mm	e mm	f mm	g mm
AK200S+A200I+A200B	210	515	820	250	555	860	365
AU200S+A200I+A200B	165	485	795	205	525	835	330

AU250S + A250I + A250B

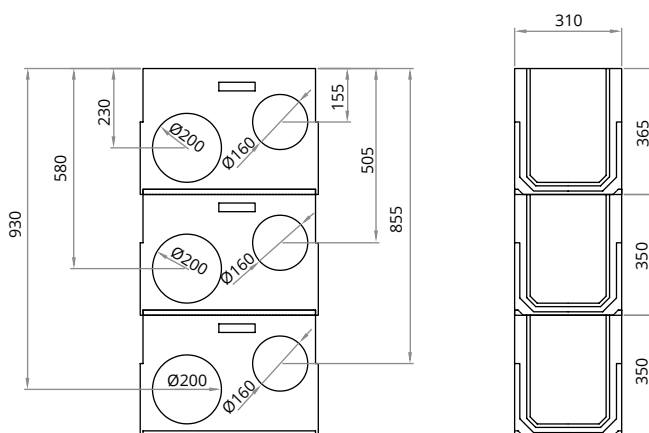

AK300S + A300I + A300B

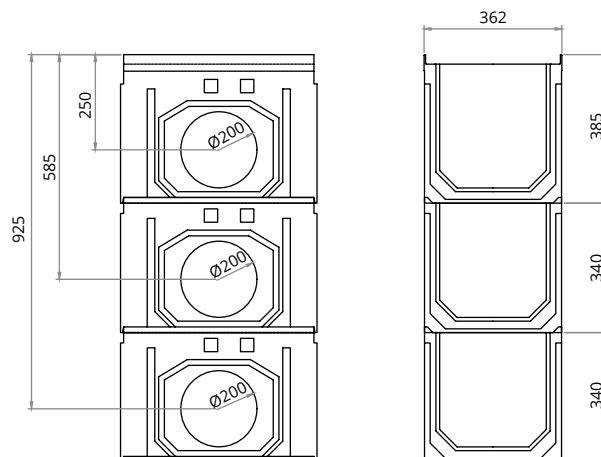



# SPORT

## SYSTEM

### Recreational areas, running tracks, football pitches...

Range of channels and accessories for sports facilities, football pitches, running tracks, indoor areas such as showers and changing rooms, pool sides, etc.

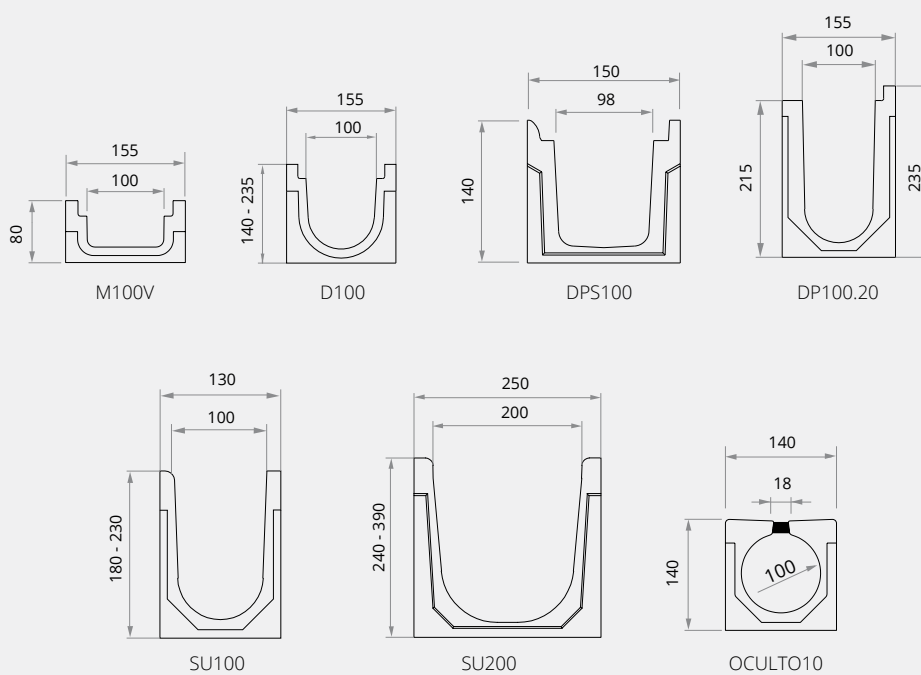

Without slope



Cascaded slope

- M100V
- D100
- DPS100
- DP100.20
- SU100
- SU200
- OCULTO10

- D100
- SU100
- SU200

Load Class  
up to C250  
EN-1433 Standard

# M100V



ULMA Linear Drainage Channel type M100V: External width 155 mm; Internal width 100mm and overall height 80 mm to collect rainwater in 1 metre long units. Locking system consists of 2 screws per metre.

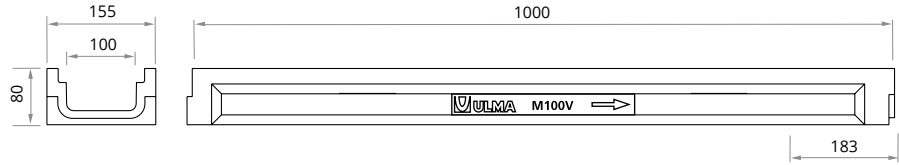

## CHANNELS

Code Channel	L mm	H mm	Width mm		Ø Outlet* mm		Hydraul. Section cm <sup>2</sup>	Pcs. pallet	Weight Kg	Qref l/s
			Ext.	Int.	Vert.	Hor.				
M100V	1000	80	155	100	90	-	40	120	11,5	0,85

\* Vertical outlets on order

## GRATINGS



Material	Design	Load	Code	L mm	Width mm	Opening mm	Weight Kg	Intake area cm <sup>2</sup> /ml	Code	Units ml
DUCTILE IRON STAINLESS	SLOTTED	D400	FIN100KCDM	500	123	19,9	3,5	695	TXE860	2
	PERFORATED	A15	GP100KCA	1000	123	Ø6	1,1	158	TNPC870	2
GALVANISED STEEL	SLOTTED	A15	GN100KCA	1000	123	9	1,6	282	TNPC860	2
	MESH	B125	GEX100KCB	1000	123	30 x 20	3,3	823	TEF860	2
	HEELPROOF MESH	B125	GEHX100KCB	1000	123	30 x 10	4,0	743	TEF860	2
STAINLESS STEEL	SLOTTED	A15	IN100KCA	1000	123	7	1,4	216	TXNPC860	2
	PERFORATED	A15	IP100KCA	1000	123	Ø6	1,2	158	TXNPC870	2
COMPOSITE	HEELPROOF SLOTTED BLACK	A15	PNH100KCAM	500	123	3	0,7	159	TXE860	2
	HEELPROOF SLOTTED GREY	A15	PNH100KCAM-GRIS	500	123	3	0,7	159	TXE860	2
	LONG SLOTTED BLACK	A15	PNLH100KCAM	500	123	3	0,4	484	TXE860	2
	LONG SLOTTED GREY	A15	PNLH100KCAM-GRIS	500	123	3	0,4	484	TXE860	2
	MESH	B125	PE100KCBM	500	123	14 x 12,5	0,5	553	TXE860	2

## HOW TO FIX

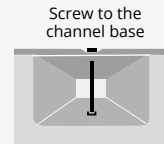

## CLOSED END CAP

Code	Image
T100MVC	



Load Class  
up to C250  
EN-1433 Standard

# D100



ULMA Linear Drainage Channel type D100: External width 155 mm; Internal width 100 mm; Available with overall heights between 140 mm and 235 mm. Suitable for cascaded type slope to collect rainwater in 1 metre long units. Locking system consists of locking bar CS100 and screws, with polymer concrete stepped edges for lateral protection.

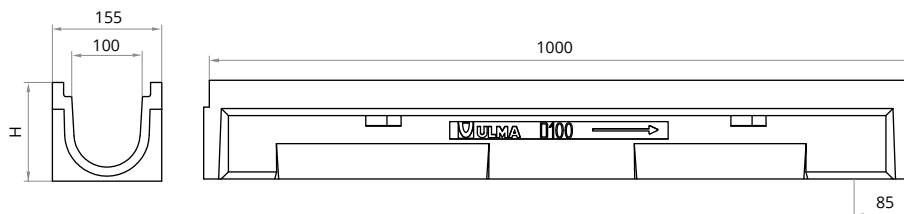

## CHANNELS

Code Channel	L mm	H mm	Width mm		Ø Outlet* mm		Hydraul. Section cm <sup>2</sup>	Pcs. pallet	Weight Kg	Qref l/s
			Ext.	Int.	Vert.	Hor.				
D100.00	1000	140	155	100	110	-	86	78	15,7	3,00
D100.05	1000	160	155	100	110	-	106	65	17,7	4,14
D100.10	1000	185	155	100	110	110	130	65	18,6	5,78
D100.15	1000	210	155	100	110	110	154	52	19,0	7,53
D100.20	1000	235	155	100	110	110	178	52	22,7	9,46

\* Vert. and horiz. outlets on order.

## GRATINGS



Material	Design	Load	Code	L mm	Width mm	Opening mm	Weight Kg	Intake area cm <sup>2</sup> /ml	Code	Units ml
DUCTILE IRON STAINLESS	SLOTTED	D400	FIN100KCDM	500	123	19,9	3,5	695	TXE850+ CS100INOX	2 + 2
GALVANISED STEEL	PERFORATED	A15	GP100KCA	1000	123	Ø6	1,1	158	TNPC870 + CS100	2 + 2
	SLOTTED	A15	GN100KCA	1000	123	9	1,6	282	TNPC870 + CS100	2 + 2
	MESH	B125	GEX100KCB	1000	123	30 x 20	3,3	823	TEF860 + CS100	2 + 2
	HEELPROOF MESH	B125	GEHX100KCB	1000	123	30 x 10	4,0	743	TEF850 + CS100	2 + 2
STAINLESS STEEL	SLOTTED	A15	IN100KCA	1000	123	7	1,4	216	TXNPC870 + CS100INOX	2 + 2
	PERFORATED	A15	IP100KCA	1000	123	Ø6	1,2	158	TXNPC870 + CS100INOX	2 + 2
COMPOSITE	HEELPROOF SLOTTED BLACK	A15	PNH100KCAM	500	123	3	0,7	159	TXE850 + CS100INOX	2 + 2
	HEELPROOF SLOTTED GREY	A15	PNH100KCAM-GRIS	500	123	3	0,7	159	TXE850 + CS100INOX	2 + 2
	LONG.SLOTTED BLACK	A15	PNLH100KCAM	500	123	3	0,4	484	TXE850 + CS100INOX	2 + 2
	LONG.SLOTTED GREY	A15	PNLH100KCAM-GRIS	500	123	3	0,4	484	TXE850 + CS100INOX	2 + 2
	MESH	B125	PE100KCBM	500	123	14 x 12,5	0,5	553	TXE850 + CS100INOX	2 + 2

## HOW TO FIX

Locking bar and  
2 screws



## SUMP UNITS

Code	L mm	H mm	Width mm	Lateral outlets Ø mm	Front outlet Ø mm	Sump units
AD100	500	560	155	110/160	90	1

## BUCKET

Code
CU100

## STEP UNITS

Code
CED100

To install in the changes of height  
with cascaded slope.

## CLOSED END CAP

Code
T100D00C
T100D05C
T100D10C
T100D15C
T100D20C



## SLOPE DESIGNS

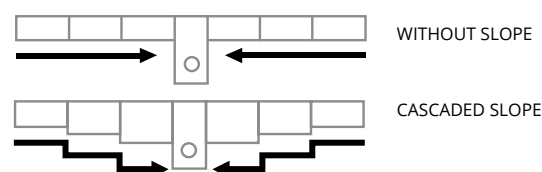



Load Class  
up to C250  
EN-1433 Standard

# DPS100



ULMA Linear Drainage Channel type DPS100: External width 150 mm; Internal width 98 mm and overall height 140 mm to collect rainwater, with side entries for additional water collection, in 1 metre long units. Locking system consists of locking bar CS100 and screws, with polymer concrete stepped edges for lateral protection.

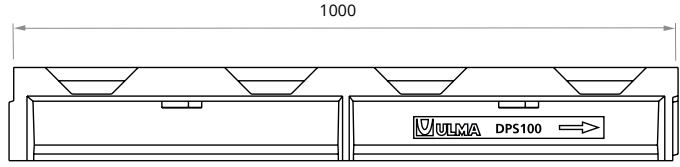
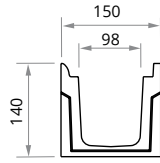

## CHANNELS

Code Channel	L mm	H mm	Width mm		Ø Outlet* mm		Hydraul. Section cm <sup>2</sup>	Pcs. pallet	Weight Kg	Qref l/s
			Ext.	Int.	Vert.	Hor.				
DPS100	1000	140	150	98	-	-	95	91	12,5	3,6

\* Vertical outlets on order

## GRATINGS

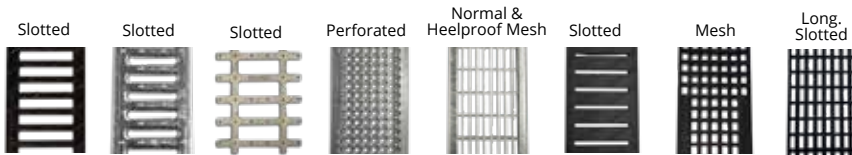

Material	Design	Load	Code	L mm	Width mm	Opening mm	Weight Kg	Intake area cm <sup>2</sup> /ml	Code	Units ml
	SLOTTED	C250	FNX100KCCM	500	123	14	2,9	486	TEF850 + CS100	2 + 2
	HEELPROOF SLOTTED	C250	FNHX100KCCM	500	123	5	3,7	174	TEF850 + CS100	2 + 2
DUCTILE IRON STAINLESS	SLOTTED	D400	FIN100KCDM	500	123	19,9	3,5	695	TXE850+CS100INOX	2 + 2
GALVANISED STEEL	PERFORATED	A15	GP100KCA	1000	123	Ø6	1,1	158	TNPC870 + CS100	2 + 2
	SLOTTED	A15	GN100KCA	1000	123	9	1,6	282	TNPC870 + CS100	2 + 2
	MESH	B125	GEX100KCB	1000	123	30 x 20	3,3	823	TEF860 + CS100	2 + 2
	HEELPROOF MESH	B125	GEHX100KCB	1000	123	30 x 10	4,0	743	TEF850 + CS100	2 + 2
STAINLESS STEEL	SLOTTED	A15	IN100KCA	1000	123	7	1,4	216	TXNPC870 + CS100INOX	2 + 2
	PERFORATED	A15	IP100KCA	1000	123	Ø6	1,2	158	TXNPC870 + CS100INOX	2 + 2
COMPOSITE	HEELPROOF SLOTTED BLACK	A15	PNH100KCAM	500	123	3	0,7	159	TXE850 + CS100INOX	2 + 2
	HEELPROOF SLOTTED GREY	A15	PNH100KCAM-GRIS	500	123	3	0,7	159	TXE850 + CS100INOX	2 + 2
	LONG.SLOTTED BLACK	A15	PNLH100KCAM	500	123	3	0,4	484	TXE850 + CS100INOX	2 + 2
	LONG.SLOTTED GREY	A15	PNLH100KCAM-GRIS	500	123	3	0,4	484	TXE850 + CS100INOX	2 + 2
	MESH	B125	PE100KCBM	500	123	14 x 12,5	0,5	553	TXE850 + CS100INOX	2 + 2

## HOW TO FIX

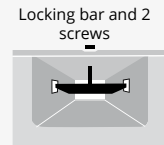

## SUMP UNITS

Code	L mm	H mm	Width mm	Lateral outlets Ø mm	Front outlet Ø mm	Sump units	Weight Kg
ADPS100	500	400	150	160	90	1	26,1

## BUCKET

Code
CEURO100

## CLOSED END CAP

Code
T100D00C



Load Class  
up to C250  
EN-1433 Standard

# DP100.20



ULMA Linear Drainage Channel type DP100.20: External width 155 mm; Internal width 100 mm and overall height 235 mm to collect rainwater in 1 metre long units. Locking system consists of locking bar CS100 and screws, with polymer concrete stepped edges for lateral protection.

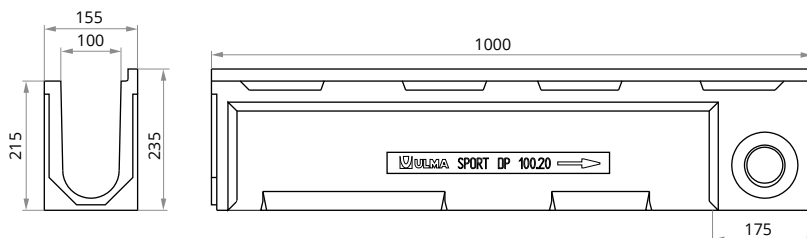

## CHANNELS

Code Channel	L mm	H mm	Width mm		Ø Outlet* mm		Hydraul. Section cm <sup>2</sup>	Pcs. pallet	Weight Kg	Qref l/s
			Ext.	Int.	Vert.	Hor.				
DP100.20	1000	235	155	100	110	110	178	52	22,7	9,4

\* Vert. and horiz. outlets on order.

## GRATINGS

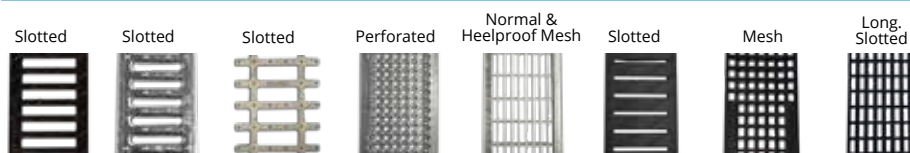

## HOW TO FIX

Locking bar and 2 screws



Material	Design	Load	Code	L mm	Width mm	Opening mm	Weight Kg	Intake area cm <sup>2</sup> /ml	Code	Units ml
SLOTTED	C250	FNX100KCCM	500	123	14	2,9	486	TEF860 + CS100	2 + 2	
HEELPROOF SLOTTED	C250	FNHX100KCCM	500	123	5	3,7	174	TEF860 + CS100	2 + 2	
DUCTILE IRON STAINLESS	SLOTTED	D400	FIN100KCDM	500	123	19,9	3,5	695	TXE860 + CS100INOX	2 + 2
GALVANISED STEEL	PERFORATED	A15	GP100KCA	1000	123	Ø6	1,1	158	TNPC870 + CS100	2 + 2
	SLOTTED	A15	GN100KCA	1000	123	9	1,6	282	TNPC870 + CS100	2 + 2
	MESH	B125	GEX100KCB	1000	123	30 x 20	3,3	823	TEF860 + CS100	2 + 2
	HEELPROOF MESH	B125	GEHX100KCB	1000	123	30 x 10	4,0	743	TEF850 + CS100	2 + 2
STAINLESS STEEL	SLOTTED	A15	IN100KCA	1000	123	7	1,4	216	TXNPC870 + CS100INOX	2 + 2
	PERFORATED	A15	IP100KCA	1000	123	Ø6	1,2	158	TXNPC870 + CS100INOX	2 + 2
COMPOSITE	HEELPROOF SLOTTED BLACK	A15	PNH100KCAM	500	123	3	0,7	159	TXE860 + CS100INOX	2 + 2
	HEELPROOF SLOTTED GREY	A15	PNH100KCAM-GRIS	500	123	3	0,7	159	TXE860 + CS100INOX	2 + 2
	LONG.SLOTTED BLACK	A15	PNLH100KCAM	500	123	3	0,4	484	TXE860 + CS100INOX	2 + 2
	LONG.SLOTTED GREY	A15	PNLH100KCAM-GRIS	500	123	3	0,4	484	TXE860 + CS100INOX	2 + 2
	MESH	B125	PE100KCBM	500	123	14 x 12,5	0,5	553	TXE860 + CS100INOX	2 + 2

## SUMP UNITS

	Code	L mm	H mm	Width mm	Lateral outlets Ø mm	Front outlet Ø mm	Sump units	Weight Kg
		ADP100	500	560	155	110/160	90	1

## BUCKET

	Code
	CU100

## CLOSED END CAP

Code	
T100D20C	



Load Class  
up to C250  
EN-1433 Standard

# SU100



ULMA Linear Drainage Channel type SU100: External width 130 mm; Internal width 100 mm and available with overall heights between 180 mm and 230 mm. Suitable for cascaded type slope to collect rainwater in 1 meter long units. Locking system consists of locking bar CS100 and screws.

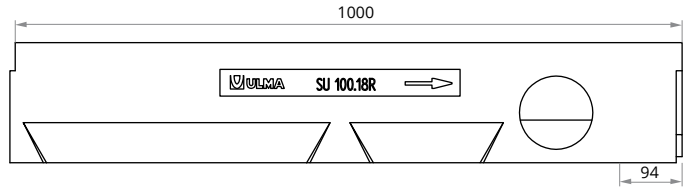
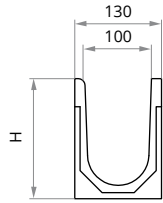

## CHANNELS

Code Channel	L mm	H mm	Width mm		Ø Outlet* mm		Hydraul. Section cm <sup>2</sup>	Pcs. pallet	Weight Kg	Qref l/s
			Ext.	Int.	Vert.	Hor.				
SU100.18R	1000	180	130	100	110	110	145	65	15,7	6,71
SU100.20R	1000	205	130	100	110	110	169	52	18,4	8,54
SU100.23R	1000	230	130	100	110	110	193	52	20,3	10,52

\* Vert. and horiz. outlets on order.

## GRATINGS

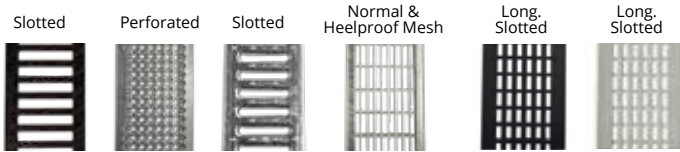

Material	Design	Load	Code	L mm	Width mm	Thickness mm	Opening mm	Weight Kg	Intake area cm <sup>2</sup> /ml
DUCTILE IRON	SLOTTED	B125	FNX100UCBM	500	130	6	14,9	2,1	530
	SLOTTED	C250	FNX100UCCM	500	130	6	13	2,7	435
GALVANISED STEEL	SLOTTED	A15	GN100UCA	1000	130	3	9	1,6	268
	PERFORATED	A15	GP100UCA	1000	130	3	Ø6	1,4	159
	MESH	B125	GEX100UCB33	1000	130	2	30 x 30	3,2	837
STAINLESS STEEL	HEELPROOF MESH	B125	GEHX100UCB	1000	130	2	30 x 10	3,9	749
	SLOTTED	A15	IN100UCA	1000	130	3	7	1,5	218
COMPOSITE	PERFORATED	A15	IP100UCA	1000	130	3	Ø6	1,7	159
	LONG SLOTTED BLACK	A15	PNLH100UCAM	500	130	3	8	0,3	367
	LONG SLOTTED GREY	A15	PNLH100UCAM-GRIS	500	130	3	8	0,3	367

## HOW TO FIX

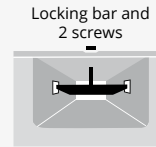

Code	Units ml
TEF840 + CS100	2 + 2
TEF840 + CS100	2 + 2
(1) TNPC850 + CS100	2 + 2
TNPC850 + CS100	2 + 2
TEF840 + CS100	2 + 2
TEF840 + CS100	2 + 2
TXNPC850 + CS100INOX	2 + 2
TXNPC850 + CS100INOX	2 + 2
(1) TXE840 + CS100INOX	2 + 2
(1) TXE840 + CS100INOX	2 + 2

(1) Click. Without screws.

## SUMP UNITS

Code	L mm	H mm	Width mm	Lateral outlets Ø mm	Front outlet Ø mm	Sump units	Weight Kg
AU100	500	470	130	110/160	110	1	29,5

## BUCKET

Code
CU100

## STEP UNITS

Code
CEU100

To install in the changes of height with cascaded slope.

## OPEN END CAP

Canal	Code	Ø mm
SU100.18R	T100U10A	110
SU100.20R	T100U15A	110
SU100.23R	T100U20A	110

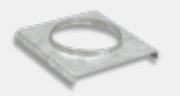

## CLOSED END CAP

Code
T100U10C
T100U15C
T100U20C

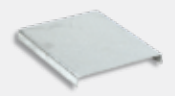

## SLOPE DESIGNS

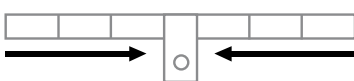

WITHOUT SLOPE

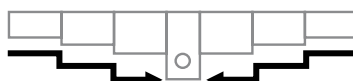

CASCADED SLOPE

**Load Class  
up to C250**  
EN-1433 Standard

# SU200



ULMA Linear Drainage Channel type SU200: External width 250 mm; Internal width 200 mm; Available with overall heights between 240 mm and 390 mm. Suitable for cascaded type slope to collect rainwater in 1 metre long units. Locking system consists of locking bar CS200 and screws.

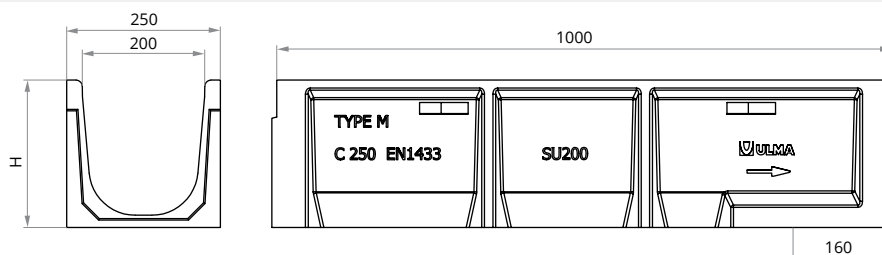

## CHANNELS

Code Channel	L mm	H mm	Width mm		Ø Outlet* mm		Hydraul. Section cm <sup>2</sup>	Pcs. pallet	Weight Kg	Qref l/s
			Ext.	Int.	Vert.	Hor.				
SU200.00R	1000	240	250	200	200	-	385	28	31,9	22,70
SU200.10R	1000	290	250	200	200	-	465	28	35,8	30,46
SU200.20R	1000	340	250	200	200	-	540	21	42,1	38,67
SU200.30R	1000	390	250	200	200	-	620	21	47,6	48,19

\* Vertical outlets on order

## GRATINGS

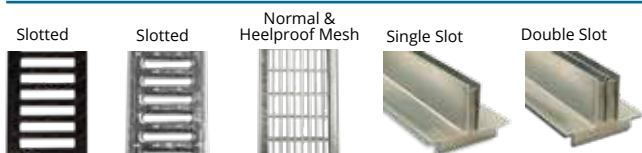

Material	Design	Load	Code	L mm	Width mm	Thickness mm	Opening mm	Weight Kg	Intake area cm <sup>2</sup> /ml
DUCTILE IRON	SLOTTED	C250	FNX200UCCM	500	250	6	10	6,7	610
	SLOTTED*	A15	GN200UCA	1000	250	4	8,5	5,2	418
GALVANISED STEEL	MESH*	B125	GEX200UCB33	1000	250	2,5	30 x 30	8,0	1634
	HEELPROOF MESH *	B125	GEHX200UCB	1000	250	2,2	30 x 10	9,5	1453
	SLOT*	C250	GR200UOC	1000	250	70	15	7,9	150
	DOUBLE SLOT*	C250	GDR200UOC	1000	250	70	2 x 12	10	240

\* Available in stainless steel, consult design

## HOW TO FIX

Locking bar and 2 screws

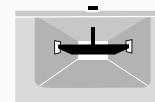

Code	Units ml
TEF1060 + CS200	2 + 2
TEF1060 + CS200	2 + 2
TEF1060 + CS200	2 + 2
TEF1060 + CS200	2 + 2
(1)	(1)
(1)	(1)

(1) Click. Without screws.

## SUMP UNITS

Code	L mm	H mm	Width mm	Lateral outlets Ø mm	Front outlet Ø mm	Sump units	Weight Kg
AU200*	500	338	260	160/200	-	1	23,2
AU200S + A200B*	500	680**	260	160/200	-	2	48,3

\* Sump units available only up to height 340 mm - SU200.20R  
\*\* The sump unit can be higher incorporating an intermediate unit.

## BUCKET

Code*
C200

\* Only applicable if 2 sump units are installed.

## OPEN END CAP

Canal	Code	Ø mm
SU200.00R	T200SU00A	200
SU200.10R	T200SU10A	200
SU200.20R	T200SU20A	200
SU200.30R	T200SU30A	200

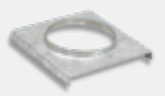

## CLOSED END CAP

Code
T200SU00C
T200SU10C
T200SU20C
T200SU30C

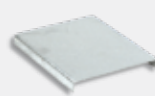

## STEP UNITS

Code
CE200



To install in the changes of height with cascaded slope.

## SLOPE DESIGNS



Load Class  
up to A15  
EN-1433 Standard

# OCULTO10



ULMA Linear Drainage Channel type OCULTO10: External width 140 mm, inside diameter 100mm and overall height 140 mm to collect rainwater in 1 metre long units.

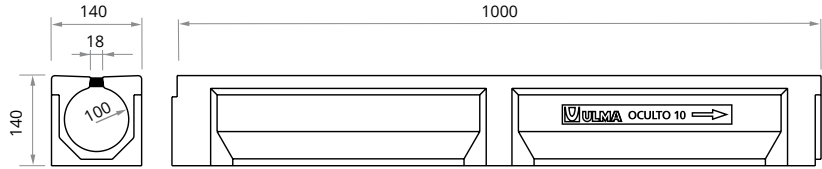

## CHANNEL

Code Channel	L mm	H mm	Width mm		Ø Outlet* mm		Hydraul. Section cm <sup>2</sup>	Pcs. pallet	Weight Kg	Qref l/s
			Ext.	Int.	Vert.	Hor.				
OCULTO10	1000	140	140	100	110	110	78,5	56	18,2	4,47

\* Vert. and horiz. outlets on order.

## GRATINGS

The channel does not have grating. Channel of one piece only.

## ACCESS UNIT GRATING



Material	Design	Load	Code	L mm	Width mm	Thickness mm	Units mm	Weight Kg	Intake area cm <sup>2</sup> /ml
POLYMER C.	SINGLE SLOT	A15	HPR100KCAM	500	110	30	2	4,1	57

## HOW TO FIX

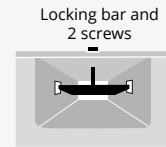

Code	Units ml
TXE860 + CS100	1+1

## SUMP UNITS



Code	L mm	H mm	Width mm	Lateral outlets Ø mm	Front outlet Ø mm	Sump units	Weight Kg
AOCULTO100S + AU100	500	612	140	110/160	110	2	7,9 + 29,4

HPR100KCAM polymer concrete grating is locked on the AOCULTO 100S sump unit and OCULTO 100RM maintenance element using a locking bar.

## HIDDEN BUCKET



Código*
COCULTO100

\*Only applicable if 2 sump units are installed.

## ACCESS UNIT



Code	L mm	Height mm	Width mm	Weight Kg
OCULTO100RM	500	140	140	9,4



# SUMP UNITS

## AD100 / ADP100

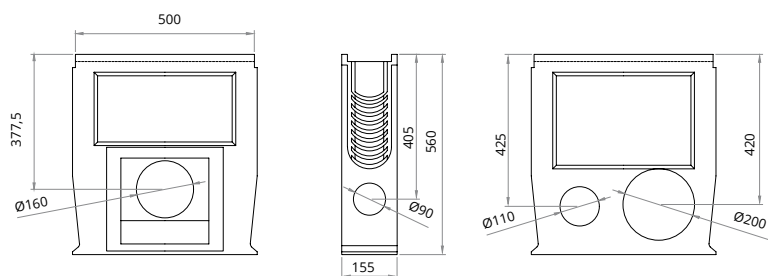

## ADPS100

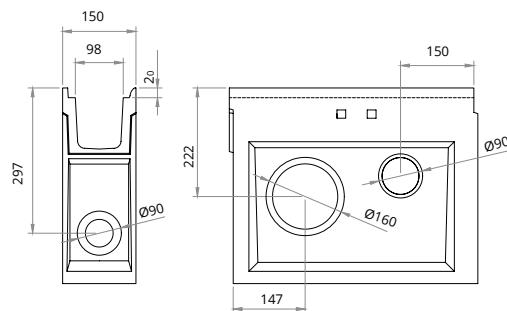

## AU100

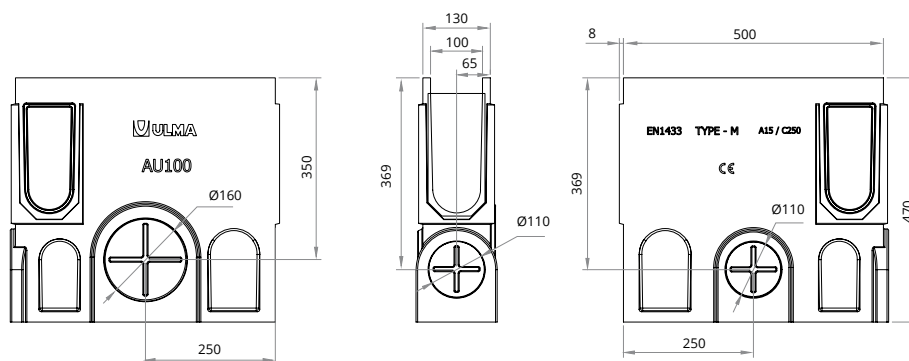

## AU200S+A200I+A200B

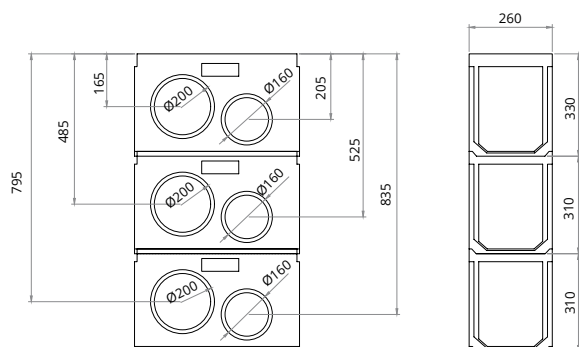

## AOCULTO100S+AU100

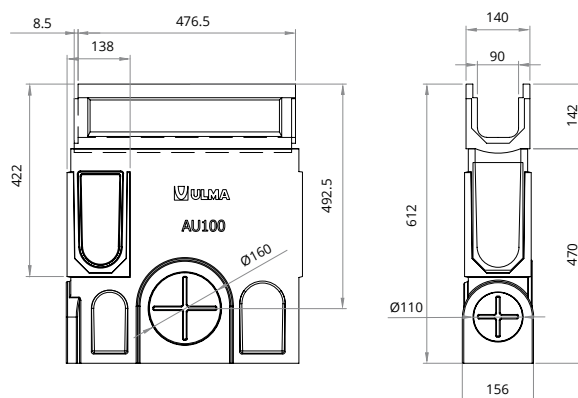



# HYDRO

## SYSTEM

**Secondary streets, squares, playgrounds, schools, parks, gardens, etc.**

Polypropylene drainage channels for pedestrian use and occasional car traffic, for areas with low hydraulic requirements.

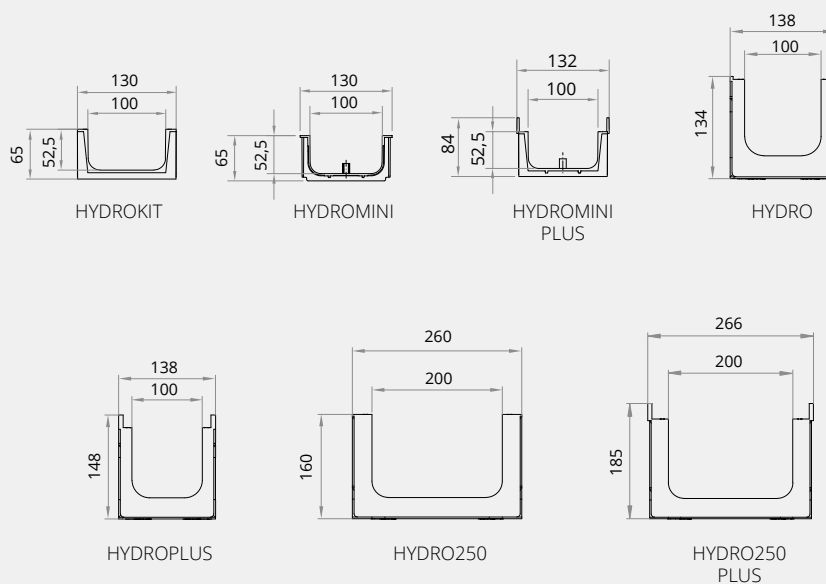



Load Class  
up to A15  
EN-1433 Standard

# HYDROKIT



Full LM consist of 1 composite linear drainage channel ULMA, to collect rainwater, type HYDROKITH65, external width 130mm, internal width 100mm and overall height 65mm. 1 Units of galvanised Steel Normal Slotted (Runway) grating, type GN100UOA, up to A-15 load class, according to EN-1433 Standard. Channel - grating locking system "click" type without screw.

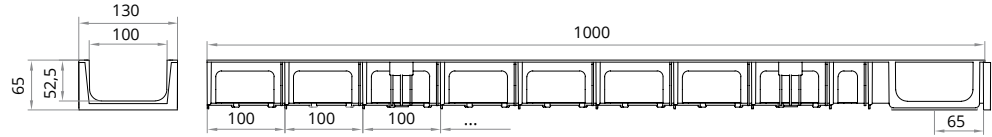

## CHANNELS

Code Channel	L mm	H mm	Width mm		Ø Outlet* mm		Hydraul. Section cm <sup>2</sup>	Pcs. pallet	Weight Kg	Qref l/s
			Ext.	Int.	Vert.	Hor.				
HYDROKITH65	1000	65	130	100	90-110	90° connection (1)	51	120	1,4	1,31

(1) Every channel has two preformed side knockouts for T, L and cross connections.

## GRATINGS

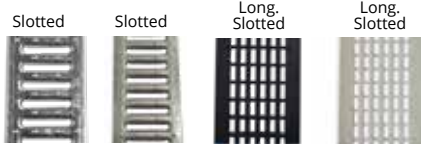

Material	Design	Load	Code	L mm	Width mm	Thickness mm	Opening Ø	Weight Kg	Intake area cm <sup>2</sup> /ml
GALVANISED STEEL	SLOTTED	A15	GN100UCA	1000	130	3	8	1,1	268
STAINLESS STEEL	SLOTTED	A15	IN100UCA	1000	130	7	7	1,5	218
COMPOSITE	LONG. SLOTTED BLACK	A15	PNLH100UCAM	500	130	3	15	0,5	367
	LONG. SLOTTED GREY	A15	PNLH100UCAM GRIS	500	130	3	15	0,5	367

## HOW TO FIX



(1) Click. Without screws.

## CLOSED END CAP

Code	
TH100H65C	

## LEAF GUARD

Code	
FS90	



Load Class  
up to C250  
EN-1433 Standard

# HYDROMINI



ULMA Linear Drainage Channel, type HYDROMINI: External width 130mm; Internal width 100mm and overall height 65mm, to collect rain water in 1 metre long units.

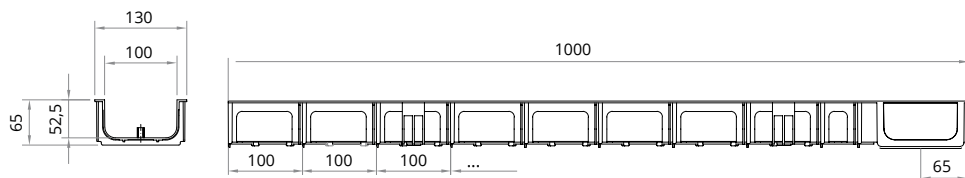

## CHANNELS

Code Channel	L mm	H mm	Width mm		Ø Outlet* mm		Hydraul. Section cm <sup>2</sup>	Pcs. pallet	Weight Kg	Qref l/s
			Ext.	Int.	Vert.	Hor.				
HYDROH65	1000	65	130	100	90-110	90° connection (1)	51	204	0,6	1,31

(1) Every channel has two preformed side knockouts for T, L and cross connections.

## GRATINGS

## HOW TO FIX

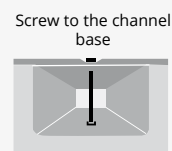

Material	Design	Load	Code	L mm	Width mm	Thickness mm	Opening Ø	Weight Kg	Intake area cm <sup>2</sup> /ml	Code	Units ml
DUCTILE IRON	SLOTTED	B125	FNX100UCBM	500	130	6	14,9	2,1	530	TEF845	2
	SLOTTED	C250	FNX100UCCM	500	130	6	13	2,7	435	TEF845	2
GALVANISED STEEL	SLOTTED	A15	GN100UCA	1000	130	3	9	1,6	268	TNPC850	2
	PERFORATED	A15	GP100UCA	1000	130	3	Ø6	1,4	159	TNPC850	2
	MESH*	B125	GEX100UCB33	1000	130	2	30 x 30	3,2	837	TEF840	2
	HEELPROOF MESH*	B125	GEHX100UCB	1000	130	2	30 x 10	0,8	749	TEF840	2
	SLOT	C250	GR100UOC	1000	130	70	15	2,8	150	(1)	(1)
	DOUBLE SLOT	C250	GDR100UOC	1000	130	70	2 x 12	5,5	240	(1)	(1)
STAINLESS STEEL	SLOTTED	A15	IN100UCA	1000	130	3	7	1,5	218	TXNPC850	2
	PERFORATED	A15	IP100UCA	1000	130	3	Ø6	1,7	159	TXNPC850	2
COMPOSITE	LONG, SLOTTED BLACK	A15	PNLH100UCAM	500	130	3	8	0,4	367	TXE840	2
	LONG, SLOTTED GREY	A15	PNLH100UCAM GRIS	500	130	3	8	0,4	367	TXE840	2

\* Available in stainless steel, consult design

(1) Click. Without screws.

## CLOSED END CAP

Code	
TH100H65C	

## LEAF GUARD

Code	
FS90	



Load Class  
up to C250  
EN-1433 Standard

# HYDROMINIPLUS



ULMA Linear Drainage Channel, type HYDROMINIPLUS: External width 132mm; Internal width 100mm and overall height 84mm, to collect rain water in 1 metre long units. The locking system consists of 2 screws per metre.



## CHANNELS

Code Channel	L mm	H mm	Width mm		Ø Outlet* mm		Hydraul. Section cm <sup>2</sup>	Pcs. pallet	Weight Kg	Qref l/s
			Ext.	Int.	Vert.	Hor.				
HYDROPLUS80	1000	84	132	100	90-110	90° connection (1)	51	170	0,79	1,31

(1) Every channel has two preformed side knockouts for T, L and cross connections.

## GRATINGS

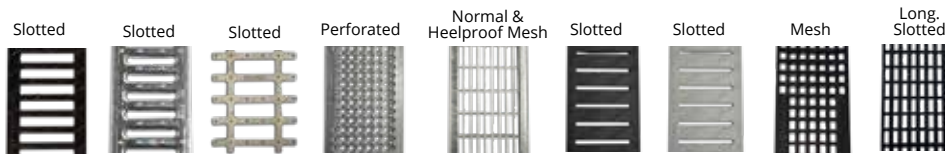

Material	Design	Load	Code	L mm	Width mm	Opening Ø	Weight Kg	Intake area cm <sup>2</sup> /ml
DUCTILE IRON	SLOTTED	B125	FNX100KCBM	500	123	14	2,7	476
	SLOTTED	C 250	FNX100KCCM	500	123	14	2,9	486
	HEELPROOF SLOTTED	C250	FNHX100KCCM	500	123	5	3,7	174
DUCTILE IRON STAINLESS	SLOTTED	D400	FIN100KCDM	500	123	19,9	3,5	695
GALVANISED STEEL	SLOTTED	A15	GN100KCA	1000	123	9	1,6	282
	PERFORATED	A15	GP100KCA	1000	123	Ø6	1,1	158
	HEELPROOF MESH*	B125	GEHX100KCB	1000	123	30 x 10	4,0	743
STAINLESS STEEL	SLOTTED	A15	IN100KCA	1000	123	7	1,4	216
	PERFORATED	A15	IP100KCA	1000	123	Ø6	1,2	158
COMPOSITE	HEELPROOF SLOTTED BLACK	A15	PNH100KCAM	500	123	5	0,6	159
	HEELPROOF SLOTTED GREY	A15	PNH100KCAM-GRIS	500	123	5	0,6	159
	LONG. SLOTTED BLACK	A15	PNLH100KCAM	500	123	8	0,4	484
	LONG. SLOTTED GREY	A15	PNLH100KCAM-GRIS	500	123	8	0,4	484
	MESH	B125	PE100KCBM	500	123	14 x 12,5	0,5	553

## HOW TO FIX

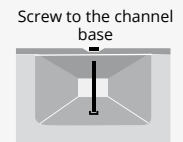

Code	Units ml
TEF860	2
TEF860	2
TEF860	2
TXE860	2
TNPC870	2
TNPC870	2
TEF860	2
TXNPC870	2
TXNPC870	2
TXE860	2
TXE860	2
TXE860	2
TXE860	2
TXE860	2

\* Available in stainless steel, consult design

## CLOSED END CAP

Code	
TH100H80C	

## LEAF GUARD

Code	
FS90	



Load Class  
up to C250  
EN-1433 Standard

# HYDRO



ULMA Linear Drainage Channel, type HYDRO: External width 138mm; Internal width 100mm and overall height 134mm, to collect rain water in 1 metre long units. Locking system consists of locking bar and screws.

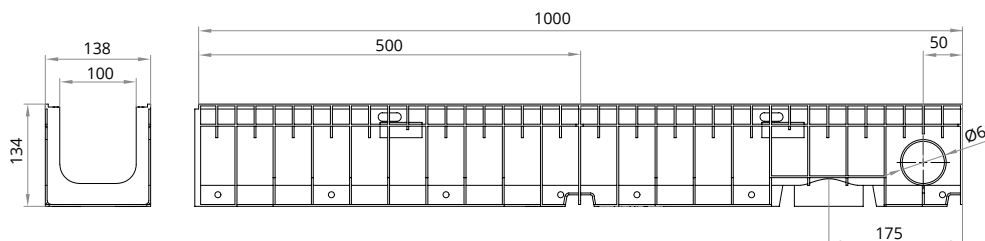

## CHANNELS

Code Channel	L mm	H mm	Width mm		Ø Outlet* mm		Hydraul. Section cm <sup>2</sup>	Pcs. pallet	Weight Kg	Qref l/s
			Ext.	Int.	Vert.	Hor.				
HYDRO	1000	134	138	100	90	60	97	90	1,4	3,66

## GRATINGS



## HOW TO FIX

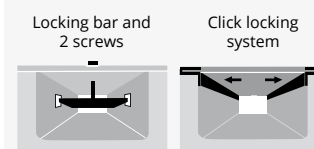

Material	Design	Load	Code	L mm	Width mm	Opening Ø	Weight Kg	Intake area cm <sup>2</sup> /ml	HOW TO FIX	
									Code	Units ml
DUCTILE IRON	SLOTTED	B125	FNX100UCBM	500	130	14,9	2,1	530	TEF840 + CS100	2 + 2
	SLOTTED	C250	FNX100UCCM	500	130	13	2,7	435	TEF840 + CS100	2 + 2
GALVANISED STEEL	SLOTTED	A15	GN100UCA	1000	130	9	1,6	268	TNPC850 + CS100	2 + 2
	PERFORATED	A15	GP100UCA	1000	130	Ø6	1,4	159	TNPC850 + CS100	2 + 2
	MESH*	B125	GEX100UCB33	1000	130	30 x 30	3,2	837	TEF840 + CS100	2 + 2
	HEELPROOF MESH *	B125	GEHX100UCB	1000	130	30 x 10	0,8	749	TEF840 + CS100	2 + 2
	SLOT	C250	GR100UOC	1000	130	15	2,8	150	(1)	(1)
	DOUBLE SLOT	C250	GDR100UOC	1000	130	2 x 12	5,5	240	(1)	(1)
STAINLESS STEEL	SLOTTED	A15	IN100UCA	1000	130	7	1,5	218	TXNPC850 + CS100INOX	2 + 2
	PERFORATED	A15	IP100UCA	1000	130	Ø6	1,7	159	TXNPC850 + CS100INOX	2 + 2
COMPOSITE	LONG. SLOTTED BLACK	A15	PNLH100UCAM	500	130	8	0,4	367	TXE840 + CS100INOX	2 + 2
	LONG. SLOTTED GREY	A15	PNLH100UCAM-GRIS	500	130	8	0,4	367	TXE840 + CS100INOX	2 + 2

\* Available in stainless steel, consult design

(1) Click. Without screws.

## OPEN END CAP

Code	Ø mm	Image
TH100A	90	

## CLOSED END CAP

Code	Image
TH100C	

## LEAF GUARD

Code	Image
FS90	

Load Class  
up to C250  
EN-1433 Standard

# HYDROPLUS



ULMA Linear Drainage Channel, type HYDROPLUS: External width 138mm; Internal width 100mm; and overall height 148mm, to collect rain water in 1 metre long units. Locking system consists of locking bar and screws.

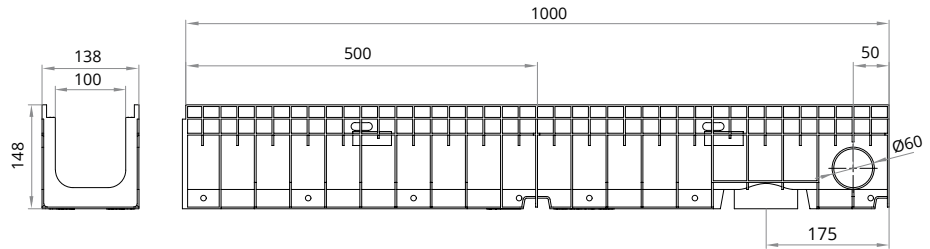

## CHANNELS

Code Channel	L mm	H mm	Width mm		Ø Outlet* mm		Hydraul. Section cm <sup>2</sup>	Pcs. pallet	Weight Kg	Qref l/s
			Ext.	Int.	Vert.	Hor.				
HYDROPLUS	1000	148	138	100	90	60	97	90	1,5	3,66

## GRATINGS

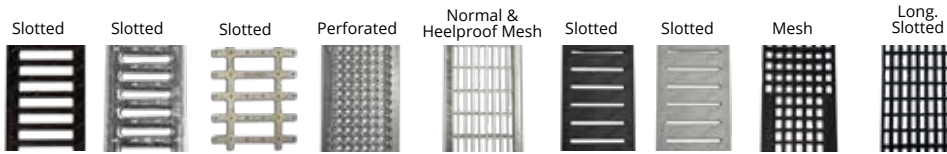

Material	Design	Load	Code	L mm	Width mm	Opening Ø	Weight Kg	Intake area cm <sup>2</sup> /ml
DUCTILE IRON	SLOTTED	B125	FNX100KCBM	500	123	14	2,7	476
	SLOTTED	C250	FNX100KCCM	500	123	14	2,9	486
	HEELPROOF SLOTTED	C250	FNHX100KCCM	500	123	5	3,7	174
DUCTILE IRON STAINLESS	SLOTTED	D400	FIN100KCDM	500	123	19,9	3,5	695
GALVANISED STEEL	SLOTTED	A15	GN100KCA	1000	123	9	1,6	282
	PERFORATED	A15	GP100KCA	1000	123	Ø6	1,1	158
	HEELPROOF MESH *	B125	GEHX100KCB	1000	123	30 x 10	4,0	743
STAINLESS STEEL	SLOTTED	A15	IN100KCA	1000	123	7	1,4	216
	PERFORATED	A15	IP100KCA	1000	123	Ø6	1,2	158
COMPOSITE	HEELPROOF SLOTTED BLACK	A15	PNH100KCAM	500	123	5	0,6	159
	HEELPROOF SLOTTED GREY LONG.	A15	PNH100KCAM-GRIS	500	123	8	0,6	159
	SLOTTED BLACK LONG.	A15	PNLH100KCAM	500	123	8	0,4	484
	SLOTTED GREY	A15	PNLH100KCAM-GRIS	500	123	8	0,4	484
	MESH	B125	PE100KCBM	500	123	14 x 12,5	0,5	553

## HOW TO FIX

Locking bar and 2 screws

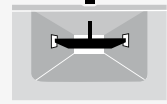

Code	Units ml
TEF850 + CS100	2 + 2
TEF850 + CS100	2 + 2
TEF850 + CS100	2 + 2
TXE860 + CS100INOX	2 + 2
TNPC870 + CS100	2 + 2
TNPC870 + CS100	2 + 2
TEF850 + CS100	2 + 2
TXNPC870 + CS100INOX	2 + 2
TXNPC870 + CS100INOX	2 + 2
TXE850 + CS100INOX	2 + 2
TXE850 + CS100INOX	2 + 2
TXE850 + CS100INOX	2 + 2
TXE850 + CS100INOX	2 + 2
TXE850 + CS100INOX	2 + 2

\* Available in stainless steel, consult design

## OPEN END CAP

Code	Ø mm
TH100KA	90

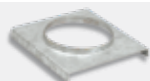

## CLOSED END CAP

Code
TH100KC

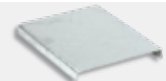

## LEAF GUARD

Code
FS90



Load Class  
up to C250  
EN-1433 Standard

# HYDRO250



ULMA Linear Drainage Channel, type HYDRO: External width 260mm; Internal width 200mm; and overall height 160mm, to collect rain water in 1 metre long units. Locking system consists of locking bar and screws.

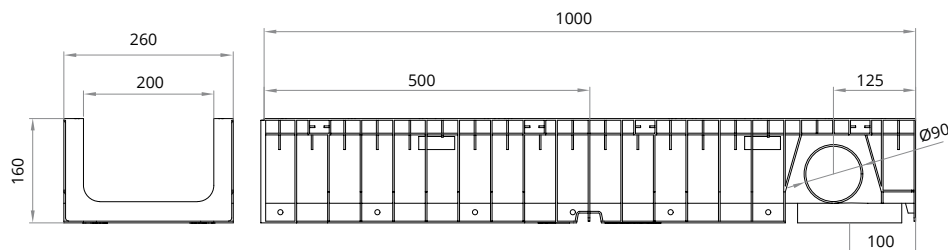

## CHANNELS

Code Channel	L mm	H mm	Width mm		Ø Outlet* mm		Hydraul. Section cm <sup>2</sup>	Pcs. pallet	Weight Kg	Qref l/s
			Ext.	Int.	Vert.	Hor.				
HYDRO250	1000	160	260	200	160	90	252	40	2,3	11,67

## GRATINGS

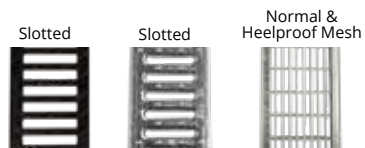

Material	Design	Load	Code	L mm	Width mm	Opening Ø	Weight Kg	Intake area cm <sup>2</sup> /ml
DUCTILE IRON	SLOTTED	C250	FNX200UCCM	500	250	10	6,7	610
GALVANISED STEEL	SLOTTED	A15	GN200UCA	1000	250	8,5	5,2	418
	MESH*	B125	GEX200UCB33	1000	250	30 x 30	8,0	1634
	HEELPROOF MESH*	B125	GEHX200UCB	1000	250	30 x 10	9,5	1453

\* Available in stainless steel, consult design

## HOW TO FIX

Locking bar and 2 screws

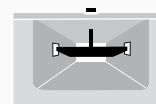

Code	Units ml
TEF1060 + CS200	2 + 2
TNPC1060 + CS200	2 + 2
TEF1060 + CS200	2 + 2
TEF1060 + CS200	2 + 2

## OPEN END CAP

Code	Ø mm
TH200A	90

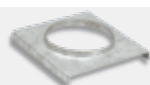

## CLOSED END CAP

Code
TH200C



Load Class  
up to C250  
EN-1433 Standard

# HYDRO250PLUS



ULMA Linear Drainage Channel , type HYDRO: External width 266mm; Internal width 200mm; and overall height 185mm, to collect rain water in 1 metre long units. Locking system consists of locking bar and screws.

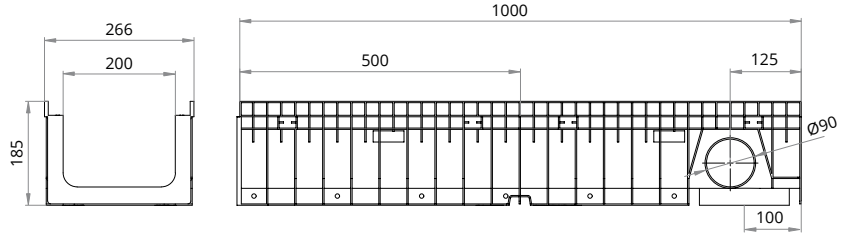

## CHANNELS

Code Channel	L mm	H mm	Width mm		Ø Outlet* mm		Hydraul. Section cm <sup>2</sup>	Pcs. pallet	Weight Kg	Qref l/s
			Ext.	Int.	Vert.	Hor.				
HYDRO250PLUS	1000	185	266	200	160	90	252	40	2,5	11,67

## GRATINGS

Slotted Mesh

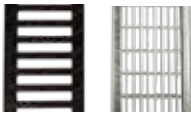

Material	Design	Load	Code	L mm	Width mm	Opening Ø	Weight Kg	Intake area cm <sup>2</sup> /ml
DUCTILE IRON	SLOTTED	C250	FNX200KCCM	500	250	14	7,2	919
GALVANISED STEEL	MESH*	B125	GEX200KCB	1000	250	30 x 20	8,0	1846

\* Available in stainless steel, consult design

## HOW TO FIX

Locking bar and 2 screws



Code	Units ml
TEF1060 + CS200	2 + 2
TEF1060 +CS200	2 + 2

## OPEN END CAP

Code	Ø mm
TH200KA	110

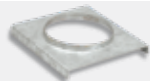

## CLOSED END CAP

Code
TH200KC









MATERIAL ELÉCTRIC FUSTER B-451

FOOT

EXIT

# TECHNICAL DRAINAGE



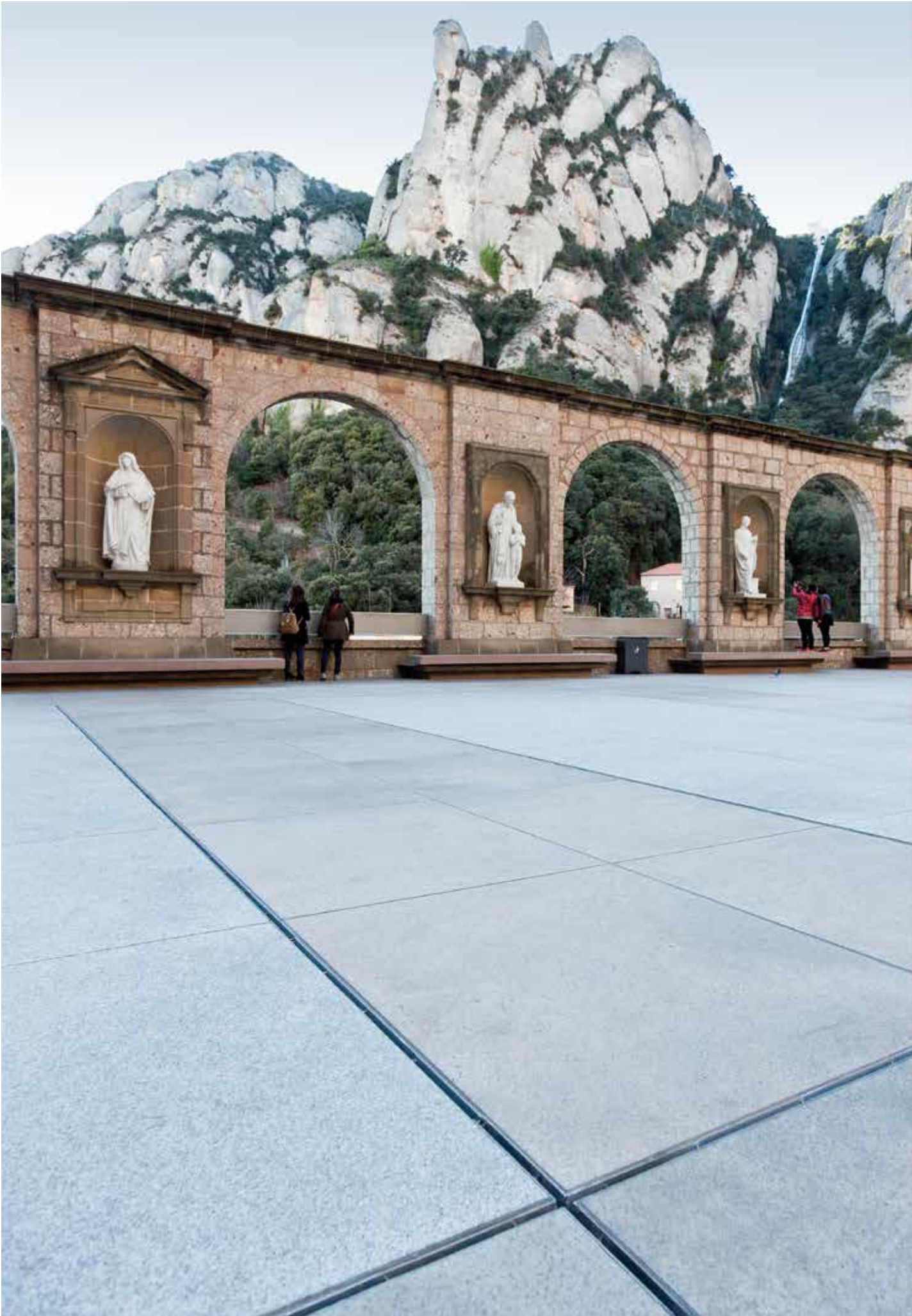

MULTIV +

TECHNICAL DRAINAGE

# MULTIV+

## SYSTEM

**Pedestrian areas, commercial areas,  
and car parks for all types of vehicles.**

### DRAINAGE EVOLUTION

The evolution of R&D processes and our 20+ years of experience in drainage solutions has enabled us to develop a new line of products better suited to market needs, providing in a single system the advantages of our other lines: the economy of the SELF system, the low heights of the MINI range, the 8-point fastening of the F line and the option of presloped, cascaded or mixed slope provided for by the U and UK systems.

The **MULTIV+®** is available in different heights, and up to a load class of D400.

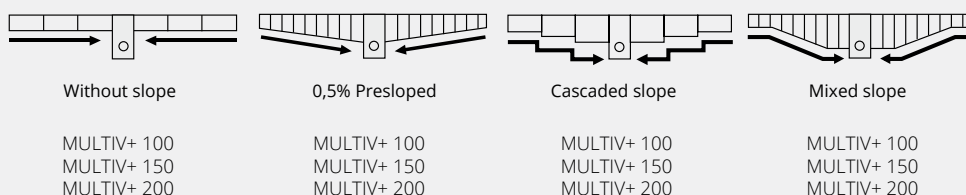
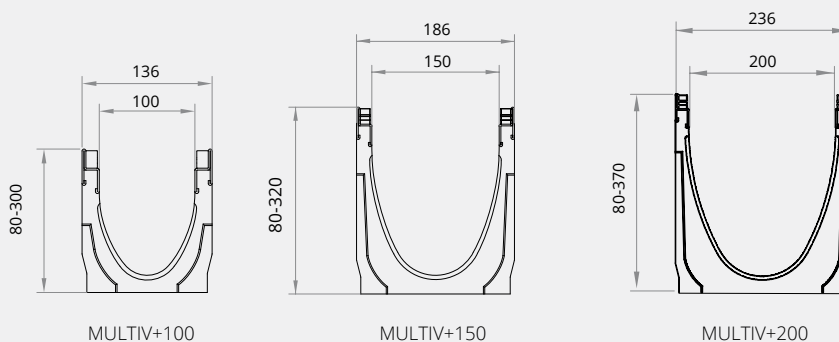

# ADVANTAGES OF THE MULTIV+ SYSTEM

## 01. MULTIV+ OPTIMIZED V-SHAPED SECTION

Especially designed for channel runs with no longitudinal slope

- + Higher speed with lower flows
- + Bigger capacity for extreme flows

The V-shaped design of the MULTIV+® channels has been developed to drain water faster, improving the self-cleaning effect of the channel. Its optimized cross section, larger than the traditional V-sections currently available on the market, provides bigger hydraulic capacity for extreme flow situations.



## 02. *rapidlock* FASTENING SYSTEM

The fast and boltless ULMA Rapidlock® fastening system makes possible to connect the grating to the channel body quickly, safely and practically effortlessly.

- One-second fastening
- Tool-free installation
- Save on labour costs
- Easy maintenance

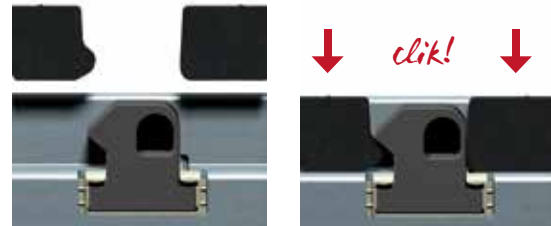

## 03. MECHANICAL STABILITY, WITH 8 FASTENING POINTS

Its 8-point fastening system provides higher stability and stress distribution throughout the grating and the channel.

## 04. MULTIPLE FASTENING OPTIONS

Rapidlock® and screw-fastened systems can be replaced and combined with blocking

- Even with already installed channels.
- No need to replace the grating.
- By simply replacing the fastening components.



# SYSTEM FEATURES

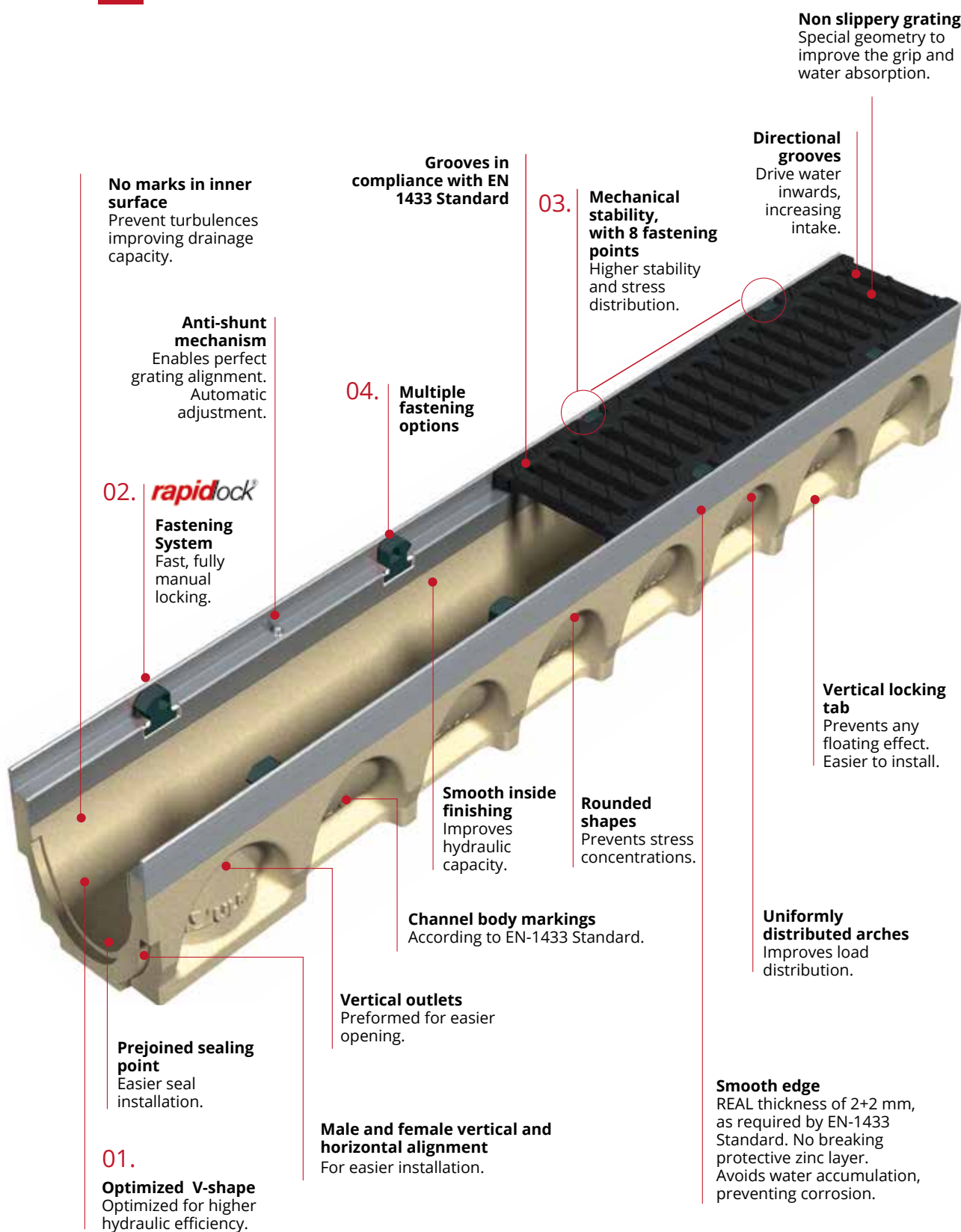

**No marks in inner surface**  
Prevent turbulences improving drainage capacity.

**Anti-shunt mechanism**  
Enables perfect grating alignment. Automatic adjustment.

02. **rapidlock**

**Fastening System**  
Fast, fully manual locking.

**Grooves in compliance with EN 1433 Standard**

03. **Mechanical stability, with 8 fastening points**  
Higher stability and stress distribution.

**Directional grooves**  
Drive water inwards, increasing intake.

**Non slippery grating**  
Special geometry to improve the grip and water absorption.

04. **Multiple fastening options**

**Vertical locking tab**  
Prevents any floating effect. Easier to install.

**Smooth inside finishing**  
Improves hydraulic capacity.

**Rounded shapes**  
Prevents stress concentrations.

**Uniformly distributed arches**  
Improves load distribution.

**Channel body markings**  
According to EN-1433 Standard.

**Prejoined sealing point**  
Easier seal installation.

**Vertical outlets**  
Preformed for easier opening.

**Smooth edge**  
REAL thickness of 2+2 mm, as required by EN-1433 Standard. No breaking protective zinc layer. Avoids water accumulation, preventing corrosion.

**Male and female vertical and horizontal alignment**  
For easier installation.

01. **Optimized V-shape**  
Optimized for higher hydraulic efficiency.

Load Class  
up to D400 (1)  
EN-1433 Standard

# MULTIV+100

SLOPE  
0,5% CE



ULMA Linear Drainage Channel, type MULTIV+ R100G; External width 136 mm, Internal width 100 mm, with overall heights between 80 and 300 mm; suitable for cascade-type slopes to collect rainwater; sections 1 LM in length; optimized V-shape with self-cleaning effect; especially designed for channel runs with no longitudinal slope; galvanised steel or ductile iron edges (2) for lateral protection; Either **Rapidlock®** boltless system or screw-fastened. 8 locking points per linear metre.

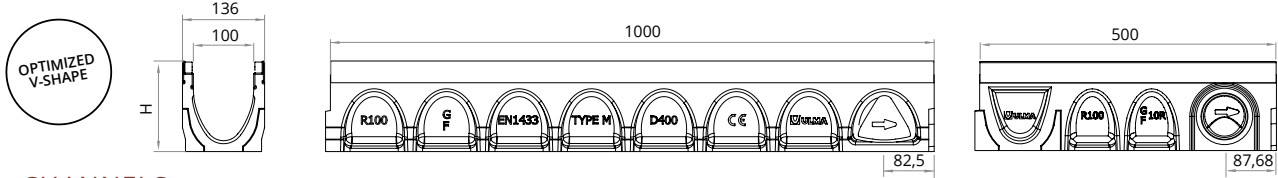

## CHANNELS

Channel Code		L mm	H mm		Width mm		Ø Outlet* mm		Hydraul. Section cm <sup>2</sup>	Units x pallet	Weight Kg	Qref l/s
Galvanised edges	Ductile Iron edges		Initial	Final	Z	X	Vert.	Hor.				
R100GH8**	-	1000	80	80	136	100	110	-	40	90	11,2	0,9
R100G00R	R100MFG00R	1000	100	100	136	100	110	-	56	90	12,2	1,5
R100G01	R100MFG01	1000	100	105	136	100	110	-	60,9	-	12,4	-
R100G02	R100MFG02	1000	105	110	136	100	110	-	64,3	-	12,8	-
R100G03	R100MFG03	1000	110	115	136	100	110	-	67,7	-	13,3	-
R100G04	R100MFG04	1000	115	120	136	100	110	-	71,1	-	13,7	-
R100G05	R100MFG05	1000	120	125	136	100	110	-	74,5	-	14,1	-
R100G06	R100MFG06	1000	125	130	136	100	110	-	77,9	-	14,5	-
R100G07	R100MFG07	1000	130	135	136	100	110	-	81,3	-	15,1	-
R100G08	R100MFG08	1000	135	140	136	100	110	-	84,7	-	15,4	-
R100G09	R100MFG09	1000	140	145	136	100	110	-	88,1	-	15,8	-
R100G10	R100MFG10	1000	145	150	136	100	110	-	91,5	-	16,3	-
R100G10R	R100MFG10R	1000	150	150	136	100	110	-	91,5	75	15,2	3,3
R100G11	R100MFG11	1000	150	155	136	100	110	-	96,5	-	15,1	-
R100G12	R100MFG12	1000	155	160	136	100	110	-	100,6	-	15,6	-
R100G13	R100MFG13	1000	160	165	136	100	110	-	104,6	-	16,0	-
R100G14	R100MFG14	1000	165	170	136	100	110	-	108,7	-	16,4	-
R100G15	R100MFG15	1000	170	175	136	100	110	-	112,7	-	16,7	-
R100G16	R100MFG16	1000	175	180	136	100	110	-	116,8	-	17,3	-
R100G17	R100MFG17	1000	180	185	136	100	110	-	120,8	-	17,7	-
R100G18	R100MFG18	1000	185	190	136	100	110	-	124,9	-	18,2	-
R100G19	R100MFG19	1000	190	195	136	100	110	-	128,9	-	18,6	-
R100G20	R100MFG20	1000	195	200	136	100	110	-	133	-	18,9	-
R100G20R	R100MFG20R	1000	200	200	136	100	110	-	133	60	18,6	6,0
R100G21	R100MFG21	1000	200	205	136	100	110	-	137,3	-	14,6	-
R100G22	R100MFG22	1000	205	210	136	100	110	-	141,6	-	15,6	-
R100G23	R100MFG23	1000	210	215	136	100	110	-	145,9	-	15,6	-
R100G24	R100MFG24	1000	215	220	136	100	110	-	150,2	-	16,7	-
R100G25	R100MFG25	1000	220	225	136	100	110	-	154,5	-	16,7	-
R100G26	R100MFG26	1000	225	230	136	100	110	-	158,8	-	16,7	-
R100G27	R100MFG27	1000	230	235	136	100	110	-	163,1	-	17,7	-
R100G28	R100MFG28	1000	235	240	136	100	110	-	167,4	-	17,7	-
R100G29	R100MFG29	1000	240	245	136	100	110	-	171,7	-	18,8	-
R100G30	R100MFG30	1000	245	250	136	100	110	-	176	-	18,8	-
R100G30R	R100MFG30R	1000	250	250	136	100	110	-	176	45	21,5	9,3
R100G40R	R100MFG40R	1000	300	300	136	100	110	-	220	45	24,7	13,0
0,5 M CHANNELS												
R100G10RM	R100MFG10RM	500	150	150	136	100	90	75	91,5	84	9,1	-
R100G20RM	R100MFG20RM	500	200	200	136	100	90	110	133	70	10,5	-

\* Vert. and horiz. outlets on order.

\*\* U shaped section.

\*\*\* Available channels with blocking screws (Code: R100F).

(1) For cross-drainage in heavy traffic areas, we recommend our KOMPAQDRAIN® system.

(2) Available Range in Stainless Steel (Code: R100GX).

# MULTIV+100

## GRATINGS

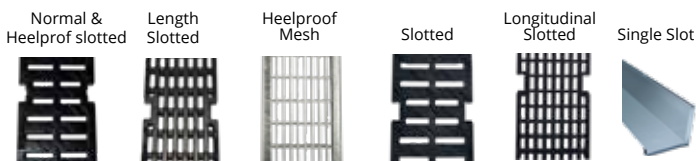

## LOCKING SYSTEM

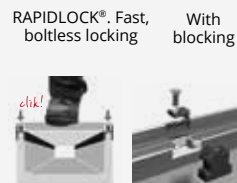

Material	Design	Load	Code	L mm	Width mm	Opening mm	Units x ml	Weight kg	Intake area cm <sup>2</sup> /ml	Locking System		
										Rapidlock	With blocking	
											Code	Units ml
DUCTILE IRON	HEELPROOF SLOTTED	B125	FNHX100RGBM	500	127	8	2	2,0	247	(2)	TR615 + BLOCK-PRG18020T	8 + 8
	HEELPROOF SLOTTED	C250	FNHX100RGCM	500	127	10	2	3,2	267	(2)		8 + 8
	SLOTTED	D400	FNX100RGDM	500	127	14	2	3,2	477	(2)		8 + 8
	HEELPROOF SLOTTED	D400	FNHX100RGDM	500	127	8	2	3,6	263	(2)		8 + 8
	LONG. SLOTTED	D400	FNLHX100RGDM	500	127	8	2	3,6	331,3	(2)		8 + 8
GALVANISED STEEL	LONG. SLOTTED (1)	A15	GNLHX100RGA	1000	127	8	1	3,3	489	(2)		8 + 8
	LONG. SLOTTED (1)	C250	GNLHX100RGC	1000	127	8	1	5,1	489	(2)		8 + 8
	HEELPROOF MESH (1)	C250	GEHX100RGC	1000	127	30 x 10	1	5,3	669	(2)		8 + 8
	HEELPROOF MESH	D400	GEHX100RGD	1000	127	30 x 10	1	5,7	670	(2)		8 + 8
	SINGLE SLOT (1)	D400	GRL100ROD	1000	127	9,8 / H105	1	7,0	98	(2)		(3)
	SINGLE SLOT (1)	D400	GRL100RODE18	1000	128	18 / H105	1	7,1	180	(2)	(3)	-
	SINGLE SLOT (1)	D400	GRL100RODH150	1000	127	9,8 / H150	1	8,5	98	(2)	(3)	-
	SINGLE SLOT (1)	D400	GRL100RODH150E18	1000	128	18 / H150	1	8,5	180	(2)	(3)	-
	SINGLE SLOT (1)	D400	GRL100RODH200	1000	131	9,8 / H200	1	10,5	98	(2)	(3)	-
COMPOSITE	LONG. SLOTTED BLACK	A15	PNLH100RGAM	500	127	8	2	0,4	468	(2)	TR615 + BLOCK-PRG18020T	8 + 8
	LONG. SLOTTED GREY	A15	PNLH100RGAM-GRIS	500	127	8	2	0,4	468	(2)		8 + 8
	HEELPROOF SLOTTED	B125	PNH100RGBM	500	127	8	2	0,9	267	(2)		8 + 8
	HEELPROOF SLOTTED	C250	PNH100RGCM	500	127	8	2	0,9	267	(2)		8 + 8

(1) Available in stainless steel, consult design

(1) Integrated into the channel  
(2) Supported

## SUMP UNITS

Code	L mm	H mm	Width mm	Lateral outlets Ø mm	Front outlet Ø mm	Sump units	Weight Kg	
								Galvanised edges
AR100G	AR100MFG	500	490	136	110/160	110	1	5,2

Code
CR100

AR100G TCR100G00MMA AR100G

R100G30 R100G29 R100G28 ..... R100G03 R100G02 R100G01 R100G01 R100G02 R100G03 ..... R100G28 R100G29 R100G30

Sump unit AR100G Outlet Diam. 110/110/160

Sump unit AR100G Outlet Diam. 110/110/160

**POLYMER CONCRETE CHANNEL WITH PRESLOPED OF 0.5%**

- Self-cleaning effect.
- Minimum maintenance.





## SLOPE DESIGNS



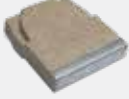

# MULTIV+100

## END CAPS

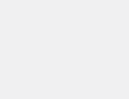
	Code channel	Material	Open			Closed
			Code	Ø mm	Accessory	Code
	R100GH8	GALVANISED STEEL	-	-	-	TR100H8
		POLYMER CONCRETE	-	-	-	THPR100GH8C (1)
	R100G00R R100MFG00R	GALVANISED STEEL	-	-	-	TR10000C
		POLYMER CONCRETE	-	-	-	THPR100G00C (1)
		POLYMER CONCRETE	-	-	-	THPR100MFG00C (2)
	R100G10R R100MFG10R	GALVANISED STEEL	TR10010A	110	-	TR10010C
		POLYMER CONCRETE	THPR100G10AJ (1)	110	Joint	THPR100G10C (1)
		POLYMER CONCRETE	THPR100G10AT (1)	110	Pipe	-
		POLYMER CONCRETE	THPR100MFG10AJ (2)	110	Joint	THPR100MFG10C (2)
		POLYMER CONCRETE	THPR100MFG10AT (2)	110	Pipe	-
	R100G20R R100MFG20R	GALVANISED STEEL	TR10020A	110	-	TR10020C
		POLYMER CONCRETE	THPR100G20AJ (1)	110	Joint	THPR100G20C (1)
		POLYMER CONCRETE	THPR100G20AT (1)	110	Pipe	-
		POLYMER CONCRETE	THPR100MFG20AJ (2)	110	Joint	THPR100MFG20C (2)
		POLYMER CONCRETE	THPR100MFG20AT (2)	110	Pipe	-
	R100G30R R100MFG30R	GALVANISED STEEL	TR10030A	110	-	TR10030C
		POLYMER CONCRETE	THPR100G30AJ (1)	110	Joint	THPR100G30C (1)
		POLYMER CONCRETE	THPR100G30AT (1)	110	Pipe	-
		POLYMER CONCRETE	THPR100MFG30AJ (2)	110	Joint	THPR100MFG30C (2)
		POLYMER CONCRETE	THPR100MFG30AT (2)	110	Pipe	-
	R100G40R R100MFG40R	GALVANISED STEEL	TR10040A	110	-	TR10040C
		POLYMER CONCRETE	THPR100G40AJ (1)	110	Joint	THPR100G40C (1)
		POLYMER CONCRETE	THPR100G40AT (1)	110	Pipe	-
		POLYMER CONCRETE	THPR100MFG40AJ (2)	110	Joint	THPR100MFG40C (2)
		POLYMER CONCRETE	THPR100MFG40AT (2)	110	Pipe	-

\*End caps also available with stainless steel edge.  
 (1) Galvanised steel edge  
 (2) Ductile Iron edge

## CONNECTORS

	Code channel	Material	Open end caps	
			Galvanised edge	Ductile Iron edge
	R100G00R	POLYMER CONCRETE	TCR100G00MMA	TCR100MF00MMA
	R100G10R	POLYMER CONCRETE	TCR100G10MMA	TCR100MF10MMA
	R100G20R	POLYMER CONCRETE	TCR100G20MMA	TCR100MF20MMA
	R100G30R	POLYMER CONCRETE	TCR100G30MMA	TCR100MF30MMA
	R100G40R	POLYMER CONCRETE	TCR100G40MMA	TCR100MF40MMA

## ACCESSORIES

	Step Units		Security lock	
	Code		Code	Units x channel
	CER100		BLOQPRG18020	8

To install in the changes of height with cascaded slope.





ULMA Linear Drainage Channel, type MULTIV+ R150G; External width 186 mm, Internal width 150 mm, with overall heights between 80 and 320 mm; suitable for cascade-type slopes to collect rainwater; sections 1 LM in length; optimized V-shape with self-cleaning effect; especially designed for channel runs with no longitudinal slope; galvanised steel or ductile iron edges (2) for lateral protection; Either **Rapidlock®** boltless system or screw-fastened. 8 locking points per linear metre.

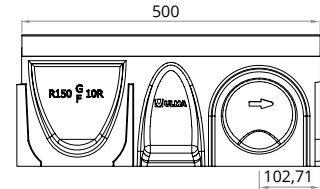
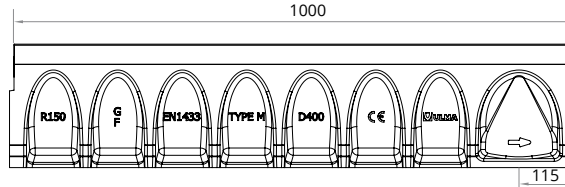
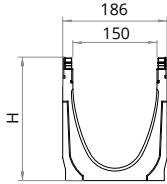

## CHANNELS

Channel Code		L mm	H mm		Width mm		Ø Outlet* mm		Hydraul. Section cm²	Units x pallet	Weight Kg	Qref l/s
Galvanised edges	Ductile Iron edges		Initial	Final	Z	X	Vert.	Hor.				
R150GH8**	-	1000	80	80	186	150	160	-	60	50	14,0	1,33
R150GH12**	-	1000	120	120	186	150	160	-	119	50	16,1	4,12
R150G00R	R150MFG00R	1000	170	170	186	150	160	-	156	45	21,6	6,33
R150G10R	R150MFG10R	1000	220	220	186	150	160	-	218	36	24,4	10,76
R150G11	R150MFG11	1000	220	225	186	150	160	-	225,5	-	24,4	-
R150G12	R150MFG12	1000	225	230	186	150	160	-	231,9	-	25,0	-
R150G13	R150MFG13	1000	230	235	186	150	160	-	238,3	-	25,4	-
R150G14	R150MFG14	1000	235	240	186	150	160	-	244,6	-	26,0	-
R150G15	R150MFG15	1000	240	245	186	150	160	-	251	-	26,1	-
R150G16	R150MFG16	1000	245	250	186	150	160	-	257,4	-	26,6	-
R150G17	R150MFG17	1000	250	255	186	150	160	-	263,8	-	27,0	-
R150G18	R150MFG18	1000	255	260	186	150	160	-	270,2	-	27,4	-
R150G19	R150MFG19	1000	260	265	186	150	160	-	276,5	-	27,8	-
R150G20	R150MFG20	1000	265	270	186	150	160	-	283	-	28,3	-
R150G20R	R150MFG20R	1000	270	270	186	150	160	-	283	36	28,2	16,14
R150G30R	R150MFG30R	1000	320	320	186	150	160	-	350	27	31,5	22,34
<b>0,5 M CHANNELS</b>												
R150G00RM	R150MFG00RM	500	170	170	186	150	110	90	156	60	12,5	-
R150G10RM	R150MFG10RM	500	220	220	186	150	110	125	218	50	14,6	-
R150G20RM	R150MFG20RM	500	270	270	186	150	110	160	283	40	17,7	-

\* Vert. and horiz. outlets on order.

\*\* U shaped section.

\*\*\* Available channels with blocking screws (Code: R100F).



(1) For cross-drainage in heavy traffic areas, we recommend our KOMPAQDRAIN® system.

(2) Available Range in Stainless Steel (Code: R100GX).

# MULTIV+150

## GRATINGS

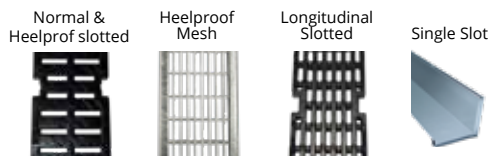

Material	Design	Load	Code	L mm	Width mm	Opening mm	Units x ml	Weight kg	Intake area cm <sup>2</sup> /ml
DUCTILE IRON	HEELPROOF SLOTTED	C250	FNHX150RGCM	500	177	8	2	5,4	391
	SLOTTED	D400	FNX150RGDM	500	177	14	2	5,5	671
	HEELPROOF SLOTTED	D400	FNHX150RGDM	500	177	8	2	6,1	390
	HEELPROOF LONG. SLOTTED	D400	FNLHX150RGDEM	500	177	8	2	8,9	384
GALVANISED STEEL	MESH (1)	C250	GEHX150RGC	1000	177	30 x 10	1	7,7	1057
	SINGLE SLOT (1)	D400	GRL150RODH200E18	1000	181	18 / H200	1	11,7	180
	SINGLE SLOT (1)	D400	GRL150ROD	1000	181	9,8 / H105	1	9,0	98
	SINGLE SLOT (1)	D400	GRL150RODE18	1000	181	18 / H105	1	8,2	180
	SINGLE SLOT (1)	D400	GRL150RODH150	1000	181	9,8 / H150	1	9,9	98
	SINGLE SLOT (1)	D400	GRL150RODH150E18	1000	181	18 / H150	1	9,9	180
	SINGLE SLOT (1)	D400	GRL150RODH200	1000	181	9,8 / H200	1	11,3	98

(1) Available in stainless steel, consult design

## LOCKING SYSTEM

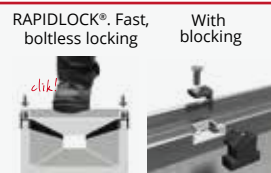

Rapidlock	With blocking		
	Code	Units ml	
(2)	TR615+ BLOCK- PRG18020T	8 + 8	
(2)		8 + 8	
(2)		8 + 8	
(2)		8 + 8	
(2)		8 + 8	
(2)		8 + 8	
(2)		(3)	-
(2)		(3)	-

(1) Integrated into the channel  
(2) Supported

## SUMP UNITS

	Code		L mm	H mm	Width mm	Lateral outlets Ø mm	Front outlet Ø mm	Sump units	Weight Kg
	Galvanised edges	Ductile Iron edges							
	AR150G	AR150MFG							

## BUCKET

	Code
	CR150

AR150G TCR150G20MMA AR150G

R150G20 R150G19 R150G18 ..... R150G13 R150G12 R150G11 R150G11 R150G12 R150G13 ..... R150G18 R150G19 R150G20

Sump unit AR150G  
Outlet Diam. 110/160/200

**POLYMER CONCRETE CHANNEL WITH PRESLOPED OF 0.5%**





- Self-cleaning effect.
- Minimum maintenance.

## SLOPE DESIGNS

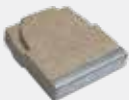

# MULTIV+150

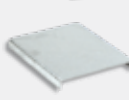
## END CAPS

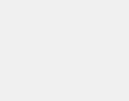
	Code channel	Material	Open			Closed
			Code	Ø mm	Accessory	Code
	R150GH8	GALVANISED STEEL	-	-	-	TR150H8C
		POLYMER CONCRETE	-	-	-	THPR150GH8C (1)
	R150GH12	GALVANISED STEEL	-	-	-	TR150H12C
		POLYMER CONCRETE	-	-	-	THPR150GH12C (1)
	R150G00R R150MFG00R	GALVANISED STEEL	TR15000A	110	-	TR15000C
		POLYMER CONCRETE	THPR150G00AJ (1)	110	Joint	-
		POLYMER CONCRETE	THPR150MFG00AT (1)	110	Pipe	THPR150G00C (1)
		POLYMER CONCRETE	THPR150MFG00AJ (2)	110	Joint	THPR150MFG00C (2)
	R150G10R R150MFG10R	GALVANISED STEEL	TR15010A	-	-	TR15010C
		POLYMER CONCRETE	THPR150G10AJ (1)	160	Joint	-
		POLYMER CONCRETE	THPR150G10AT (1)	160	Pipe	THPR150G10C (1)
		POLYMER CONCRETE	THPR150MFG10AJ (2)	160	Joint	THPR150MFG10C (2)
	R150G20R R150MFG20R	POLYMER CONCRETE	THPR150MFG10AT (2)	160	Pipe	-
		GALVANISED STEEL	TR15020A	-	-	TR15020C
		POLYMER CONCRETE	THPR150G20AJ (1)	160	Joint	-
		POLYMER CONCRETE	THPR150G20AT (1)	160	Pipe	THPR150G20C (1)
	R150G30R R150MFG30R	POLYMER CONCRETE	THPR150MFG20AJ (2)	160	Joint	THPR150MFG20C (2)
		POLYMER CONCRETE	THPR150MFG20AT (2)	160	Pipe	-
		GALVANISED STEEL	TR15030A	-	-	TR15030C
		POLYMER CONCRETE	THPR150G30AJ (1)	160	Joint	-
		POLYMER CONCRETE	THPR150G30AT (1)	160	Pipe	THPR150G30C (1)
		POLYMER CONCRETE	THPR150MFG30AJ (2)	160	Joint	THPR150MFG30C (2)
		POLYMER CONCRETE	THPR150MFG30AT (2)	160	Pipe	-

\*End caps also available with stainless steel edge.

(1) Galvanised steel edge

(2) Ductile Iron edge

## CONNECTORS

	Code channel	Material	Open end caps	
			Galvanised edge	Ductile Iron edge
	R150G00R	POLYMERBETON	TCR150G00MMA	TCR150MF00MMA
	R150G10R	POLYMERBETON	TCR150G10MMA	TCR150MF10MMA
	R150G20R	POLYMERBETON	TCR150G20MMA	TCR150MF20MMA
	R150G30R	POLYMERBETON	TCR150G30MMA	TCR150MF30MMA

## ACCESSORIES

	Step Units
	Code
	CER150

To install in the changes of height with cascaded slope.

	Security lock	
	Code	Units x channel
	BLOQPRG18020	8







ULMA Linear Drainage Channel, type MULTIV+ R200G, External width 236 mm, Internal width 200 mm, with overall heights between 80 and 370 mm; suitable for cascade-type slopes to collect rainwater; sections 1 LM in length; optimized V-shape with self-cleaning effect; especially designed for channel runs with no longitudinal slope; galvanised steel edges (2) for lateral protection; Either **Rapidlock®** boltless system or screw-fastened. 8 locking points per linear metre.

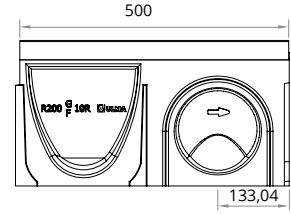
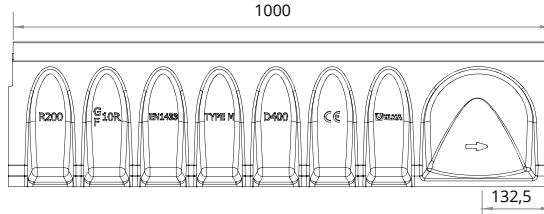
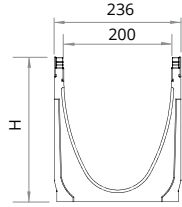

## CHANNELS

Channel Code		L mm	H mm		Width mm		Ø Outlet* mm		Hydraul. Section cm²	Units x pallet	Weight Kg	Qref l/s
Galvanised edges	Ductile iron edges		Initial	Final	Z	X	Vert.	Hor.				
R200GH8**	-	1000	80	80	236	200	160	-	79	48	16,5	1,96
R200GH12**	-	1000	120	120	236	200	160	-	159	36	19,3	5,81
R200G00R	R200MFG00R	1000	170	170	236	200	200	-	204	35	25,2	8,41
R200G00R	R200MFG00R	1000	220	220	236	200	200	-	284	28	28,9	14,11
R200G01	R200MFG01	1000	220	225	236	200	200	-	294,6	-	29,5	-
R200G02	R200MFG02	1000	225	230	236	200	200	-	302,7	-	30,0	-
R200G03	R200MFG03	1000	230	235	236	200	200	-	310,9	-	30,2	-
R200G04	R200MFG04	1000	235	240	236	200	200	-	319	-	30,7	-
R200G05	R200MFG05	1000	240	245	236	200	200	-	327,2	-	31,2	-
R200G06	R200MFG06	1000	245	250	236	200	200	-	335,3	-	31,7	-
R200G07	R200MFG07	1000	250	255	236	200	200	-	343,5	-	32,1	-
R200G08	R200MFG08	1000	255	260	236	200	200	-	351,6	-	32,5	-
R200G09	R200MFG09	1000	260	265	236	200	200	-	359,8	-	32,9	-
R200G10	R200MFG10	1000	265	270	236	200	200	-	368	-	33,4	-
R200G10R	R200MFG10R	1000	270	270	236	200	200	-	368	28	33,4	21,09
R200G11	R200MFG11	1000	270	275	236	200	200	-	388,4	-	33,6	-
R200G12	R200MFG12	1000	275	280	236	200	200	-	396,1	-	34,0	-
R200G13	R200MFG13	1000	280	285	236	200	200	-	403,8	-	34,5	-
R200G14	R200MFG14	1000	285	290	236	200	200	-	411,6	-	34,9	-
R200G15	R200MFG15	1000	290	295	236	200	200	-	419,3	-	35,2	-
R200G16	R200MFG16	1000	295	300	236	200	200	-	427	-	35,4	-
R200G17	R200MFG17	1000	300	305	236	200	200	-	434,8	-	36,3	-
R200G18	R200MFG18	1000	305	310	236	200	200	-	442,5	-	36,6	-
R200G19	R200MFG19	1000	310	315	236	200	200	-	450,2	-	37,1	-
R200G20	R200MFG20	1000	315	320	236	200	200	-	458	-	37,4	-
R200G20R	R200MFG20R	1000	320	320	236	200	200	-	458	21	37,5	29,24
R200G30R	R200MFG30R	1000	370	370	236	200	200	-	542	21	41,6	38,39
<b>0,5 M CHANNELS</b>												
R200G00RM	R200MFG00RM	500	220	220	236	200	160	125	284	32	19,8	-
R200G10RM	R200MFG10RM	500	270	270	236	200	160	160	368	32	21,7	-
R200G20RM	R200MFG20RM	500	270	270	236	200	160	160	368	42	21,7	-

\* Vert. and horiz. outlets on order.

\*\* U shaped section.

\*\*\* Available channels with blocking screws (Code: R200F).

(1) For cross-drainage in heavy traffic areas, we recommend our KOMPAQDRAIN® system.

(2) Available Range in Stainless Steel. (Code: R200GX).

# MULTIV+200

## GRATINGS

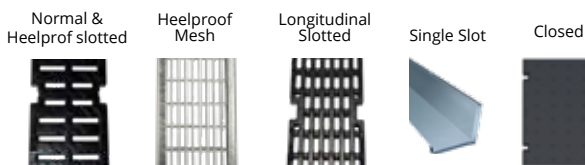

Material	Design	Load	Code	L mm	Width mm	Opening mm	Units x ml	Weight kg	Intake area cm <sup>2</sup> /ml
DUCTILE IRON	HEELPROOF SLOTTED	C250	FNHX200RGCM	500	227	8	2	7,1	535
	SLOTTED	D400	FNX200RGDM	500	227	14	2	7,8	920
	HEELPROOF SLOTTED	D400	FNHX200RGDM	500	227	8	2	8,3	544
	HEELPROOF LONG. SLOTTED	D400	FNLHX200RGDEM	500	227	8	2	9,9	503
	CLOSED	D400	FC200RGDEM	500	227	-	2	8,5	-
GALVANISED STEEL	HEELPROOF MESH (1)	C250	GEHX200RGC	1000	227	30 x 10	2	10,6	1453
	SINGLE SLOT (1)	D400	GRL200ROD	1000	231	9,8 / H105	1	11,0	98
	SINGLE SLOT (1)	D400	GRL200RODH150	1000	231	9,8 / H150	1	12,6	98
	SINGLE SLOT (1)	D400	GRL200RODH200	1000	231	9,8 / H200	1	14,5	98
	SINGLE SLOT (1)	D400	GRL200RODE18	1000	231	18 / H105	1	11,1	180
	SINGLE SLOT (1)	D400	GRL200RODH150E18	1000	231	18 / H150	1	13,9	180
	SINGLE SLOT (1)	D400	GRL200RODH200E18	1000	231	18 / H200	1	14,5	180

(1) Available in stainless steel, consult design

## LOCKING SYSTEM

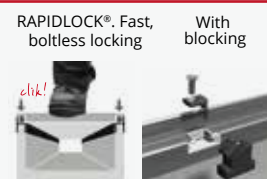

Rapidlock	With blocking	
	Code	Units ml
(2)		8 + 8
(2)		8 + 8
(2)	TR615+ BLOCK-PRG18020T	8 + 8
(2)		8 + 8
(2)		8 + 8
(2)	(3)	-
(2)	(3)	-
(2)	(3)	-
(2)	(3)	-
(2)	(3)	-

(1) Integrated into the channel  
(2) Supported

## SUMP UNITS

	Code		L mm	H mm	Width mm	Lateral outlets Ø mm	Front outlet Ø mm	Sump units	Weight Kg
	Galvanised edges	Ductile iron edges							
	AR200G	AR200MFG	500	550	236	160/200	110	1	42,2



AR200G TCR200G20MMA AR200G

R200G20 R200G19 R200G18 ..... R200G13 R200G12 R200G11 | R200G11 R200G12 R200G13 ..... R200G18 R200G19 R200G20

Sump unit AR200G  
Outlet Diam. 110/160/200

**POLYMER CONCRETE CHANNEL WITH PRESLOPED OF 0.5%**

- Self-cleaning effect.
- Minimum maintenance.







## SLOPE DESIGNS



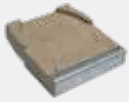

# MULTIV+200

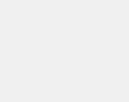
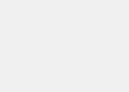
## END CAPS

	Code channel	Material	Open			Closed
			Code	Ø mm	Accessory	Code
	R200GH8	GALVANISED STEEL	-	-	-	TR200H8C
		POLYMER CONCRETE	-	-	-	THPR200GH8C
	R200GH12	GALVANISED STEEL	-	-	-	TR200H12C
		POLYMER CONCRETE	-	-	-	THPR200GH12C
	R200G000R R200MFG000R	GALVANISED STEEL	TR200000A	110	-	TR200000C
		POLYMER CONCRETE	THPR200G000AJ (1)	110	Joint	THPR200G000C
		POLYMER CONCRETE	THPR200G000AT (1)	110	Pipe	-
		POLYMER CONCRETE	THPR200MFG000AJ (2)	110	Joint	THPR200MFG000C
	R200G00R R200MFG00R	POLYMER CONCRETE	THPR200MFG000AT (2)	110	Pipe	-
		GALVANISED STEEL	TR20000A	160	-	TR20000C
		POLYMER CONCRETE	THPR200G00AJ (1)	160	Joint	THPR200G00C
		POLYMER CONCRETE	THPR200G00AT (1)	160	Pipe	-
	R200G10R R200MFG10R	POLYMER CONCRETE	THPR200MFG00AJ (2)	160	Joint	THPR200MFG00C
		POLYMER CONCRETE	THPR200MFG00AT (2)	160	Pipe	-
		GALVANISED STEEL	TR20010A	-	-	TR20010C
		POLYMER CONCRETE	THPR200G10AJ (1)	160	Joint	THPR200G10C
	R200G20R R200MFG20R	POLYMER CONCRETE	THPR200G10AT (1)	160	Pipe	-
		POLYMER CONCRETE	THPR200MFG10AJ (2)	160	Joint	THPR200MFG10C
		POLYMER CONCRETE	THPR200MFG10AT (2)	160	Pipe	-
		GALVANISED STEEL	TR20020A	-	-	TR20020C
	R200G30R R200MFG30R	POLYMER CONCRETE	THPR200G20AJ (1)	160	Joint	THPR200G20C
		POLYMER CONCRETE	THPR200G20AT (1)	160	Pipe	-
		POLYMER CONCRETE	THPR200MFG20AJ (2)	160	Joint	THPR200MFG20C
		POLYMER CONCRETE	THPR200MFG20AT (2)	160	Pipe	-
	R200G30R R200MFG30R	GALVANISED STEEL	TR20030A	-	-	TR20030C
		POLYMER CONCRETE	THPR200G30AJ (1)	160	Joint	THPR200G30C
		POLYMER CONCRETE	THPR200G30AT (1)	160	Pipe	-
		POLYMER CONCRETE	THPR200MFG30AJ (2)	160	Joint	THPR200MFG30C
		POLYMER CONCRETE	THPR200MFG30AT (2)	160	Pipe	-

\*End caps also available with stainless steel edge.

(1) Galvanised steel edge

(2) Ductile Iron edge

## CONNECTORS

	Code channel	Material	Open end caps	
			Galvanised edge	Ductile Iron edge
	R200G00R	POLYMERBETON	TCR200G00MMA	TCR200MF00MMA
	R200G10R	POLYMERBETON	TCR200G10MMA	TCR200MF10MMA
	R200G20R	POLYMERBETON	TCR200G20MMA	TCR200MF20MMA
	R200G30R	POLYMERBETON	TCR200G30MMA	TCR200MF30MMA

## ACCESSORIES

	Step Units
	Code
	CER200

	Security lock	
	Code	Units x channel
	BLOQPRG18020	8

To install in the changes of height with cascaded slope.



# SUMP UNITS

AR100G / AR100MFG / AR150G / AR150MFG / AR200G / AR200MFG

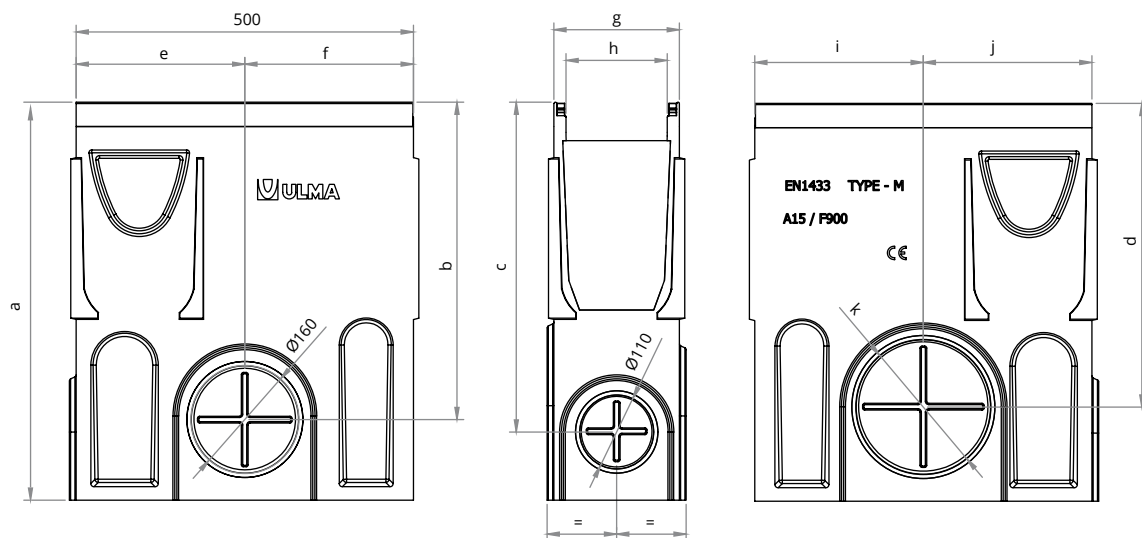

Code channel	a mm	b mm	c mm	d mm	e mm	f mm	g mm	h mm	i mm	j mm	k mm
AR100G/AR100MFG	490	370	390	390	250	250	136	100	250	250	110
AR150G/AR150MFG	590	470	490	450	250	250	186	150	250	250	200
AR200G/AR200MFG	550	430	460	425	360	140	236	200	140	360	200



# CIVIL

## DRAINAGE

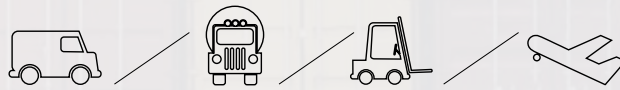

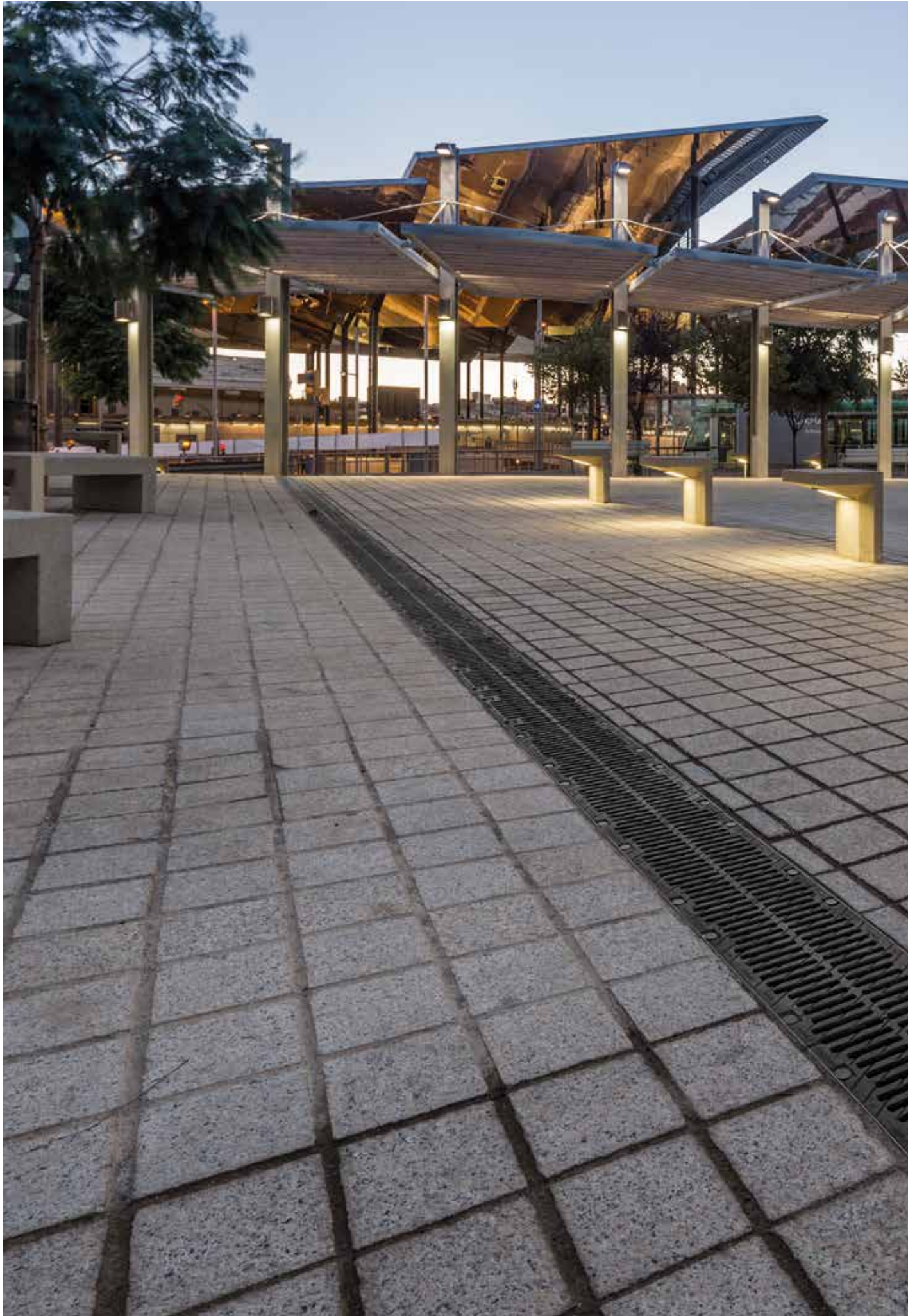

CIVIL-S

CIVIL DRAINAGE



# CIVIL-S

## SYSTEM

**Airports, warehouses, car parks for heavy vehicles...**

Channels for heavy loads with attachment with 4 screws per grating, designed for heavy traffic areas. They are channels with galvanised steel profiles at the sides.

The maximum load class will be F-900 (depending on model).

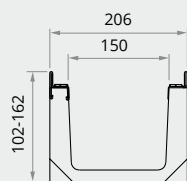

S200F

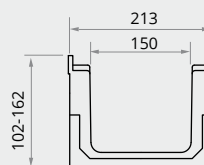

S200MF

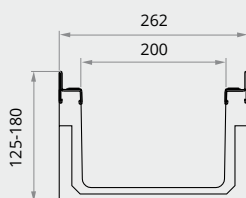

S250F

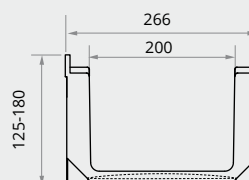

S250MF

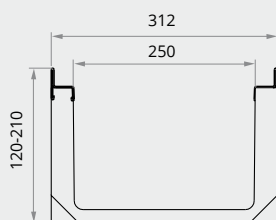

S300F

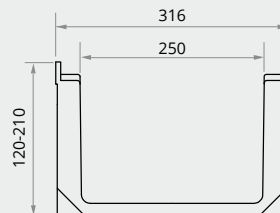

S300MF

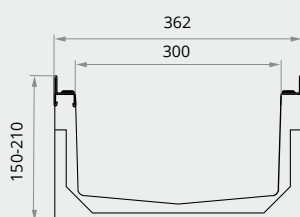

S350F

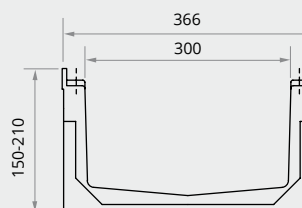

S350MF

Load Class  
up to F900  
EN-1433 Standard

# S200F



ULMA Linear Drainage Channel type S200F: External width 206 mm; Internal width 150 mm and overall height between 102 and 162 mm to collect rainwater in 1 metre long units. Safe locking system consists of eight bolts per LM; Integrated galvanised steel edges for lateral protection.

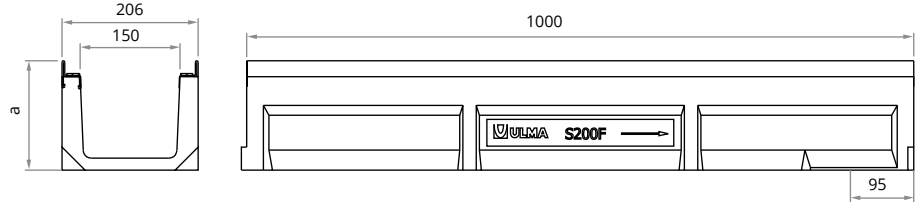

## CHANNELS

Code Channel	L mm	H mm	Width mm		Ø Outlet* mm		Hydraul. Section cm <sup>2</sup>	Pcs. pallet	Weight Kg	Qref l/s
			Ext.	Int.	Vert.	Hor.				
SM200F	1000	102	206	150	160	-	88	60	18,4	2,52
S200F	1000	162	206	150	160	-	180	40	21,5	7,68

\* Vert. outlets on order.

## GRATINGS



Material	Design	Load	Code	L mm	Width mm	Opening mm	Weight Kg	Intake area cm <sup>2</sup> /ml
DUCTILE IRON	SLOTTED	D400	FNX150FTDM	500	195	13,75	6,2	672
	HEELPROOF SLOTTED	D400	FNHX150FTDM	500	195	8	6,4	364
	SLOTTED	E600	FNX150FTEM	500	195	19	7,0	672
	SLOTTED	F900	FNX150FTFM	500	195	19	7,3	723
	HEELPROOF SLOTTED	F900	FNHX150FTFM	500	195	8	8,5	364
	CLOSED	F900	FC150FTFM	500	195	-	12,2	-
DUCTILE IRON STAINLESS	SLOTTED	D400	FIN150FTDM	500	195	25	9,9	566

## HOW TO FIX

8 screws per metre



Code	Units ml
TF1023 + TP	8 + 8
TF1023 + TP	8 + 8
TF1023 + TP	8 + 8
TF1023 + TP	8 + 8
TF1023 + TP	8 + 8
TF1023 + TP	8 + 8
TFX1020	8

## SUMP UNITS



Code	L mm	H mm	Width mm	Lateral outlets Ø mm	Front outlet Ø mm	Sump units	Weight Kg
AS200F	500	400	206	160/200	-	1	29,6

## BUCKET



Code
CSELF200

## OPEN END CAP

Code	Ø mm
TSELF200KA	110

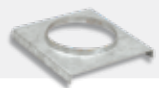

## CLOSED END CAP

Code
TSELF200KC
TSM200

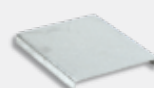

Load Class  
up to F900  
EN-1433 Standard

# S200MF



ULMA Linear Drainage Channel type S200MF: External width 213 mm; Internal width 150 mm and overall height between 102 and 162 mm to collect rainwater in 1 metre long units. Safe locking system consists of eight bolts per LM; Integrated galvanised steel edges for lateral protection.

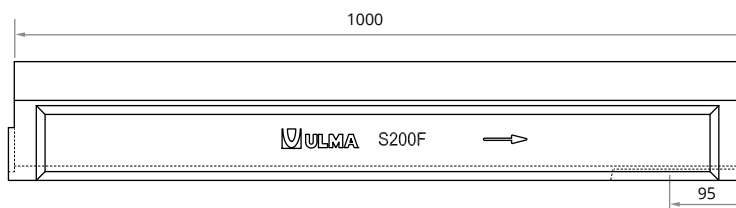
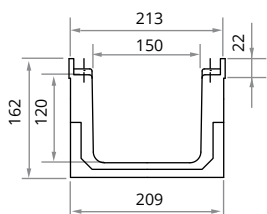

## CHANNELS

Code Channel	L mm	H mm	Width mm		Ø Outlet* mm		Hydraul. Section cm <sup>2</sup>	Pcs. pallet	Weight Kg	Qref l/s
			Ext.	Int.	Vert.	Hor.				
S200MF	1000	162	213	150	160	-	180	40	22,1	7,68

\* Vert. outlets on order.

## GRATINGS

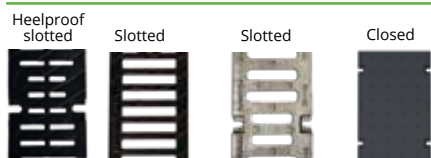

Material	Design	Load	Code	L mm	Width mm	Opening mm	Weight Kg	Intake area cm <sup>2</sup> /ml
DUCTILE IRON	SLOTTED	D400	FNX150FTDM	500	195	13,75	6,2	672
	HEELPROOF SLOTTED	D400	FNHX150FTDM	500	195	8	6,4	364
	SLOTTED	E600	FNX150FTEM	500	195	19	7,0	672
	SLOTTED	F900	FNX150FTFM	500	195	19	7,3	723
	HEELPROOF SLOTTED	F900	FNHX150FTFM	500	195	8	8,5	364
	CLOSED	F900	FC150FTFM	500	195	-	12,2	-
DUCTILE IRON STAINLESS	SLOTTED	D400	FIN150FTDM	500	195	25	9,9	566

## HOW TO FIX

8 screws per metre



Code	Units ml
TF1023 + TP	8 + 8
TF1023 + TP	8 + 8
TF1023 + TP	8 + 8
TF1023 + TP	8 + 8
TF1023 + TP	8 + 8
TF1023 + TP	8 + 8
TFX1020	8

## SUMP UNITS

Code	L mm	H mm	Width mm	Lateral outlets Ø mm	Front outlet Ø mm	Sump units	Weight Kg
AS200MF	500	400	213	160/200	-	1	30,6

## BUCKET

Code
CSELF200

## OPEN END CAP

Code	Ø mm
TSELF200KA	110

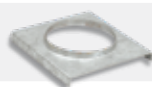

## CLOSED END CAP

Code
TSELF200KC
TSM200

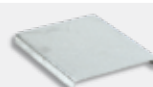



Load Class  
up to F900  
EN-1433 Standard

# S250F



ULMA Linear Drainage Channel type S250F: External width 262 mm; Internal width 200 mm and overall height between 125 and 180 mm to collect rainwater in 1 metre long units. Safe locking system consists of eight bolts per LM; Integrated galvanised steel edges for lateral protection.

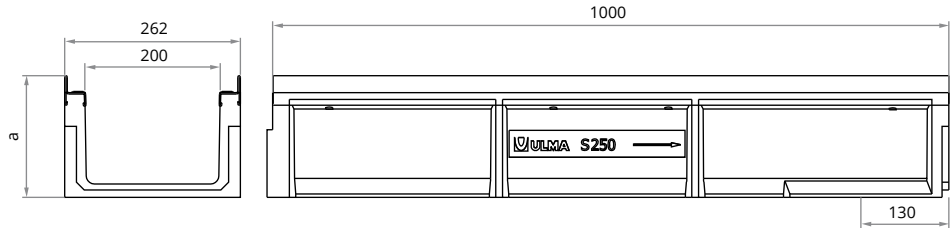

## CHANNELS

Code Channel	L mm	H mm	Width mm		Ø Outlet* mm		Hydraul. Section cm <sup>2</sup>	Pcs. pallet	Weight Kg	Qref l/s
			Ext.	Int.	Vert.	Hor.				
SM250F	1000	125	262	200	160	-	157	40	25,1	5,48
S250F	1000	180	262	200	160/200	-	260	28	31,8	12,58

\* Vert. outlets on order.

## GRATINGS

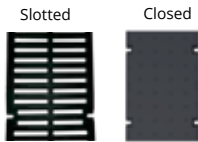

Material	Design	Load	Code	L mm	Width mm	Opening mm	Weight Kg	Intake area cm <sup>2</sup> /ml
DUCTILE IRON	SLOTTED	D400	FNX200FTDM	500	251	13,75	8,3	552
	SLOTTED	E600	FNX200FTEM	500	251	13,75	10,1	552
	SLOTTED	F900	FNX200FTFM	500	251	19	10,1	920
	CLOSED	F900	FC200FTFM	500	251	-	13,3	-

## HOW TO FIX

8 screws per metre



Code	Units ml
TF1023 + TP	8 + 8
TF1023 + TP	8 + 8
TF1023 + TP	8 + 8
TF1023 + TP	8 + 8

## SUMP UNITS



Code	L mm	H mm	Width mm	Lateral outlets Ø mm	Front outlet Ø mm	Sump units	Weight Kg
AS250F	500	500	262	315	160	1	48,2

## BUCKET



Code
C200

## OPEN END CAP

Code	Ø mm
TSELF250KA	160

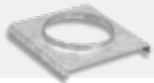

## CLOSED END CAP

Code
TSELF250KC
T200MKC

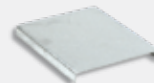

Load Class  
up to F900  
EN-1433 Standard

# S250MF

CE

ULMA Linear Drainage Channel type S250MF: External width 266 mm; Internal width 200 mm and overall height between 125 and 180 mm to collect rainwater in 1 metre long units. Safe locking system consists of eight bolts per LM; Integrated galvanised steel edges for lateral protection.

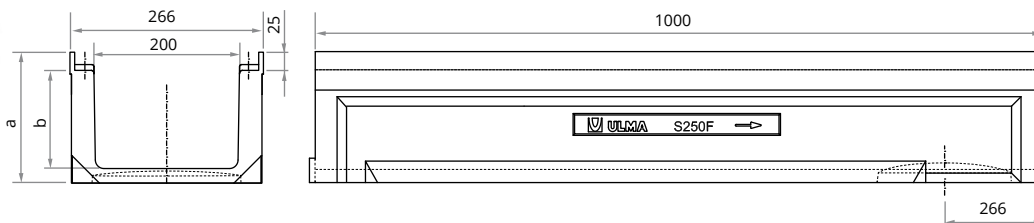

## CHANNELS

Code Channel	L mm	H mm	Width mm		Ø Outlet* mm		Hydraul. Section cm <sup>2</sup>	Pcs. pallet	Weight Kg	Qref l/s
			Ext.	Int.	Vert.	Hor.				
SM250MF	1000	125	266	200	160	-	157	40	26,8	5,48
S250MF	1000	180	266	200	160/200	-	260	28	48,9	12,58

\* Vert. outlets on order.

## GRATINGS

Slotted Closed



Material	Design	Load	Code	L mm	Width mm	Opening mm	Weight Kg	Intake area cm <sup>2</sup> /ml
DUCTILE IRON	SLOTTED	D400	FNX200FTDM	500	251	13,75	8,3	552
	SLOTTED	E600	FNX200FTEM	500	251	13,75	10,1	552
	SLOTTED	F900	FNX200FTFM	500	251	19	10,1	920
	CLOSED	F900	FC200FTFM	500	251	-	13,3	-

## HOW TO FIX

8 screws per metre

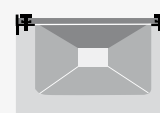

Code	Units ml
TF1023 + TP	8 + 8
TF1023 + TP	8 + 8
TF1023 + TP	8 + 8
TF1023 + TP	8 + 8

## SUMP UNITS



Code	L mm	H mm	Width mm	Lateral outlets Ø mm	Front outlet Ø mm	Sump units	Weight Kg
AS250MF	500	500	266	315	160	1	48,9

## BUCKET



Code
C200

## OPEN END CAP

Code	Ø mm
TSELF250KA	160

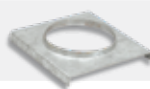

## CLOSED END CAP

Code
TSELF250KC
T200MKC



Load Class  
up to F900  
EN-1433 Standard

# S300F



ULMA Linear Drainage Channel type S300F: External width 312 mm; Internal Width 250 mm and overall height between 120 and 210 mm to collect rainwater in 1 metre long units. Safe locking system consists of eight bolts per LM; Integrated galvanised steel edges for lateral protection.

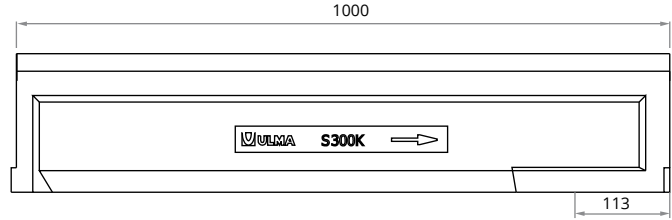
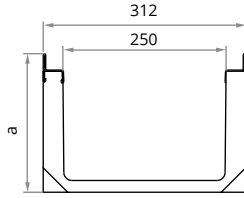

## CHANNELS

Code Channel	L mm	H mm	Width mm		Ø Outlet* mm		Hydraul. Section cm <sup>2</sup>	Pcs. pallet	Weight Kg	Qref l/s
			Ext.	Int.	Vert.	Hor.				
SM300F	1000	120	312	250	200	-	185	24	25,2	6,21
S300F	1000	210	312	250	200	-	407	24	34,5	22,18

\*Vert. outlets on order.

## GRATINGS

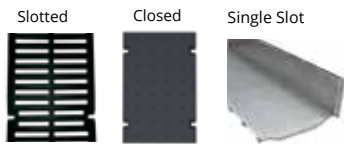

Material	Design	Load	Code	L mm	Width mm	Opening mm	Weight Kg	Intake area cm <sup>2</sup> /ml	Code	Units ml
DUCTILE IRON	SLOTTED	C250	FNX250FTCM	500	301	13,75	11,3	1146	TF1023 + TP	8 + 8
	SLOTTED	D400	FNX250FTDM	500	301	13,75	13,2	1146	TF1023 + TP	8 + 8
	SLOTTED	F900	FNX250FTFM	500	301	19	20,4	1185	TF1023 + TP	8 + 8
	CLOSED	F900	FC250FTFM	500	301	-	23,9	-	TF1023 + TP	8 + 8
GALVANISED STEEL	SINGLE SLOT	D400	GRL250FOD	1000	301	18 / H150	22,9	180	(1)	(1)

## HOW TO FIX

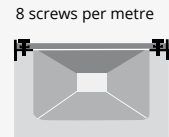

(1) Click. Without screws.

## OPEN END CAP

Code	Ø mm	Image
TSELF300KA	160	

## CLOSED END CAP

Code	Image
TSELF300KC	
TSM300C	



**Load Class  
up to F900**  
EN-1433 Standard

# S300MF



ULMA Linear Drainage Channel type S300MF: External width 316 mm; Internal Width 250 mm and overall height between 120 and 210 mm to collect rainwater in 1 metre long units. Safe locking system consists of eight bolts per LM; Integrated galvanised steel edges for lateral protection.

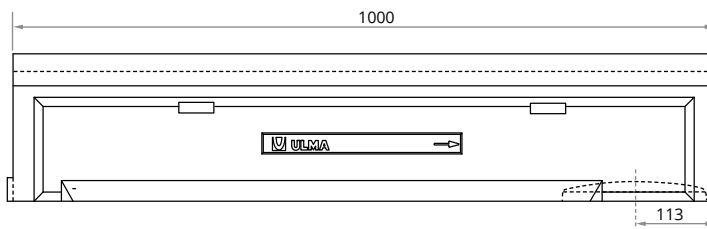
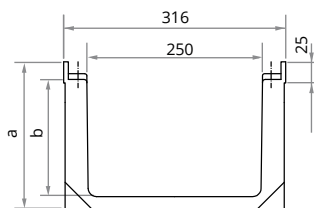

## CHANNELS

Code Channel	L mm	H mm	Width mm		Ø Outlet* mm		Hydraul. Section cm <sup>2</sup>	Pcs. pallet	Weight Kg	Qref l/s
			Ext.	Int.	Vert.	Hor.				
SM300MF	1000	120	316	250	200	-	185	24	26,0	6,21
S300MF	1000	210	316	250	200	-	407	24	35,3	22,18

\*Vert. outlets on order.

## GRATINGS

Slotted

Closed

Single Slot



Material	Design	Load	Code	L mm	Width mm	Opening mm	Weight Kg	Intake area cm <sup>2</sup> /ml	Code	Units ml
DUCTILE IRON	SLOTTED	C250	FNX250FTCM	500	301	13,75	11,3	1146	TF1023 + TP	8 + 8
	SLOTTED	D400	FNX250FTDM	500	301	13,75	13,2	1146	TF1023 + TP	8 + 8
	SLOTTED	F900	FNX250FTFM	500	301	19	20,4	1185	TF1023 + TP	8 + 8
	CLOSED	F900	FC250FTFM	500	301	-	23,9	-	TF1023 + TP	8 + 8
GALVANISED STEEL	SINGLE SLOT	D400	GRL250FOD	1000	301	18 / H150	22,9	180	(1)	(1)

## HOW TO FIX

8 screws per metre



(1) Click. Without screws.

## OPEN END CAP

Code	Ø mm	
TSELF300KA	160	

## CLOSED END CAP

Code	
TSELF300KC	
TSM300C	



Load Class  
up to F900  
EN-1433 Standard

# S350F



ULMA Linear Drainage Channel type S350F: External width 362 mm; Internal width 300 mm and overall height between 150 and 210 mm to collect rainwater in 1 metre long units. Safe locking system consists of eight bolts per LM; Integrated galvanised steel edges for lateral protection.

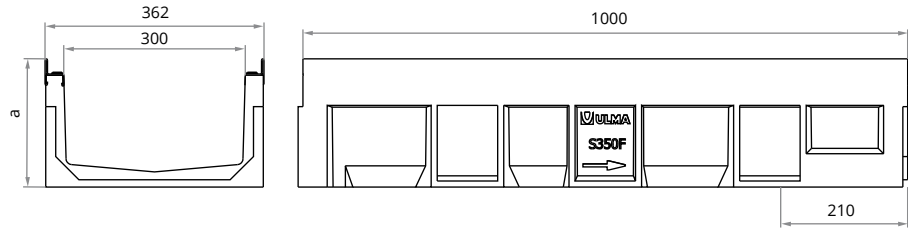

## CHANNELS

Code Channel	L mm	H mm	Width mm		Ø Outlet* mm		Hydraul. Section cm²	Pcs. pallet	Weight Kg	Qref l/s
			Ext.	Int.	Vert.	Hor.				
SM350F	1000	150	362	300	200	-	294	24	41,1	11,84
S350F	1000	210	362	300	250	-	455	18	43,3	23,47

\*Vert. outlets on order.

## GRATINGS

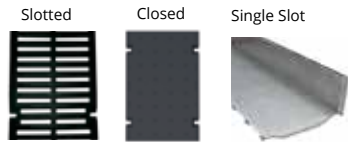

Material	Design	Load	Code	L mm	Width mm	Opening mm	Weight Kg	Intake area cm²/ml
DUCTILE IRON	SLOTTED	C250	FNX300FTCM	500	351	13,75	13,2	1351
	SLOTTED	D400	FNX300FTDM	500	351	13,75	17,8	1340
	SLOTTED	F900	FNX300FTFM	500	351	14	27,1	1371
	CLOSED	D400	FC300FTDM	500	351	-	16,3	-
	CLOSED	F900	FC300FTFM	500	351	-	29,4	-
GALVANISED STEEL	SINGLE SLOT	D400	GRL300FOD	1000	351	18 / H150	26,0	180

## HOW TO FIX

8 screws per metre



Code	Units ml
TF1023 + TP	8 + 8
TF1023 + TP	8 + 8
TF1023 + TP	8 + 8
TF1023 + TP	8 + 8
TF1023 + TP	8 + 8
(1)	(1)

(1) Click. Without screws.

## SUMP UNITS

Code	L mm	H mm	Width mm	Lateral outlets Ø mm	Front outlet Ø mm	Sump units	Weight Kg
AS350F	500	500	362	315	160 / 200	1	56,6

## BUCKET

Code
CSELF350

## OPEN END CAP

Code	Ø mm
TSELF350KA	160

## CLOSED END CAP

Code
TSELF350KC
T300MKC



Load Class  
up to F900  
EN-1433 Standard

# S350MF

CE

ULMA Linear Drainage Channel type S350MF: External width 366 mm; Internal width 300 mm and overall height between 150 and 210 mm to collect rainwater in 1 metre long units. Safe locking system consists of eight bolts per LM; Integrated galvanised steel edges for lateral protection.

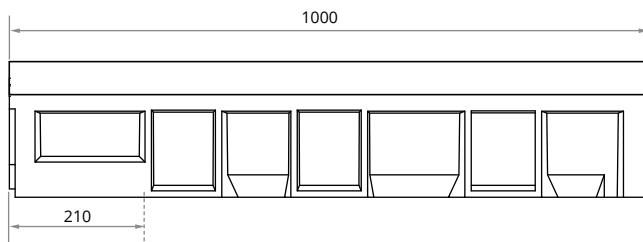
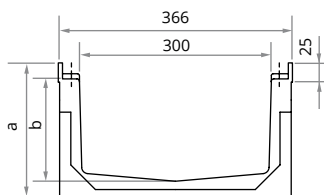

## CHANNELS

Code Channel	L mm	H mm	Width mm		Ø Outlet* mm		Hydraul. Section cm <sup>2</sup>	Pcs. pallet	Weight Kg	Qref l/s
			Ext.	Int.	Vert.	Hor.				
SM350MF	1000	150	366	300	200	-	294	24	42,7	11,84
S350MF	1000	210	366	300	250	-	455	18	57,2	23,47

\*Vert. outlets on order.

## GRATINGS

Slotted Closed Single Slot



Material	Design	Load	Code	L mm	Width mm	Opening mm	Weight Kg	Intake area cm <sup>2</sup> /ml
DUCTILE IRON	SLOTTED	C250	FNX300FTCM	500	351	13,75	13,2	1351
	SLOTTED	D400	FNX300FTDM	500	351	13,75	17,8	1340
	SLOTTED	F900	FNX300FTFM	500	351	14	27,1	1371
	CLOSED	D400	FC300FTDM	500	351	-	16,3	-
	CLOSED	F900	FC300FTFM	500	351	-	29,4	-
GALVANISED STEEL	SINGLE SLOT	D400	GRL300FOD	1000	351	18 / H150	26,0	180

## HOW TO FIX

8 screws per metre



Code	Units ml
TF1023 + TP	8 + 8
TF1023 + TP	8 + 8
TF1023 + TP	8 + 8
TF1023 + TP	8 + 8
TF1023 + TP	8 + 8
(1)	(1)

(1) Click. Without screws.

## SUMP UNITS



Code	L mm	H mm	Width mm	Lateral outlets Ø mm	Front outlet Ø mm	Sump units	Weight Kg
AS350MF	500	500	366	315	160 / 200	1	57,2

## BUCKET



Code
CSELF350

## OPEN END CAP

Code	Ø mm
TSELF350KA	160

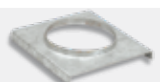

## CLOSED END CAP

Code
TSELF350KC
T300MKC



# SUMP UNITS

## AS200F / AS200MF\*

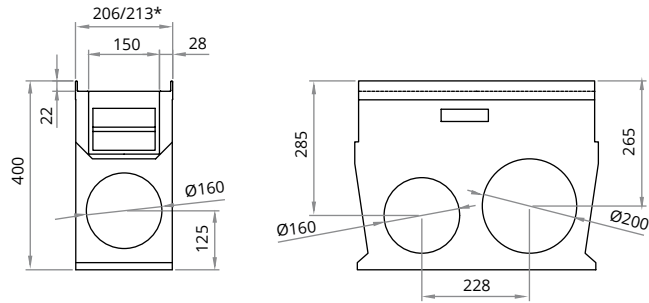

## AS250F / AS250MF / AS350F / AS350MF

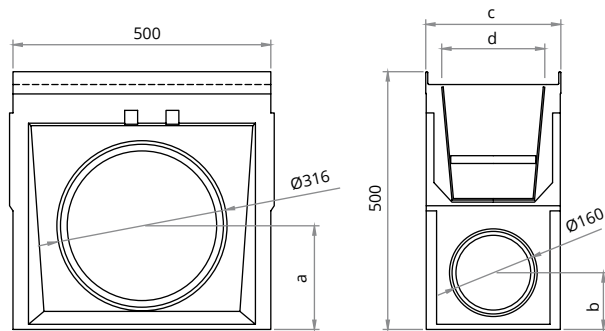

Code channel	a mm	b mm	c mm	d mm
AS250F/AS250MF	200	110	262	200
AS350F/AS350MF	185	105	362	300





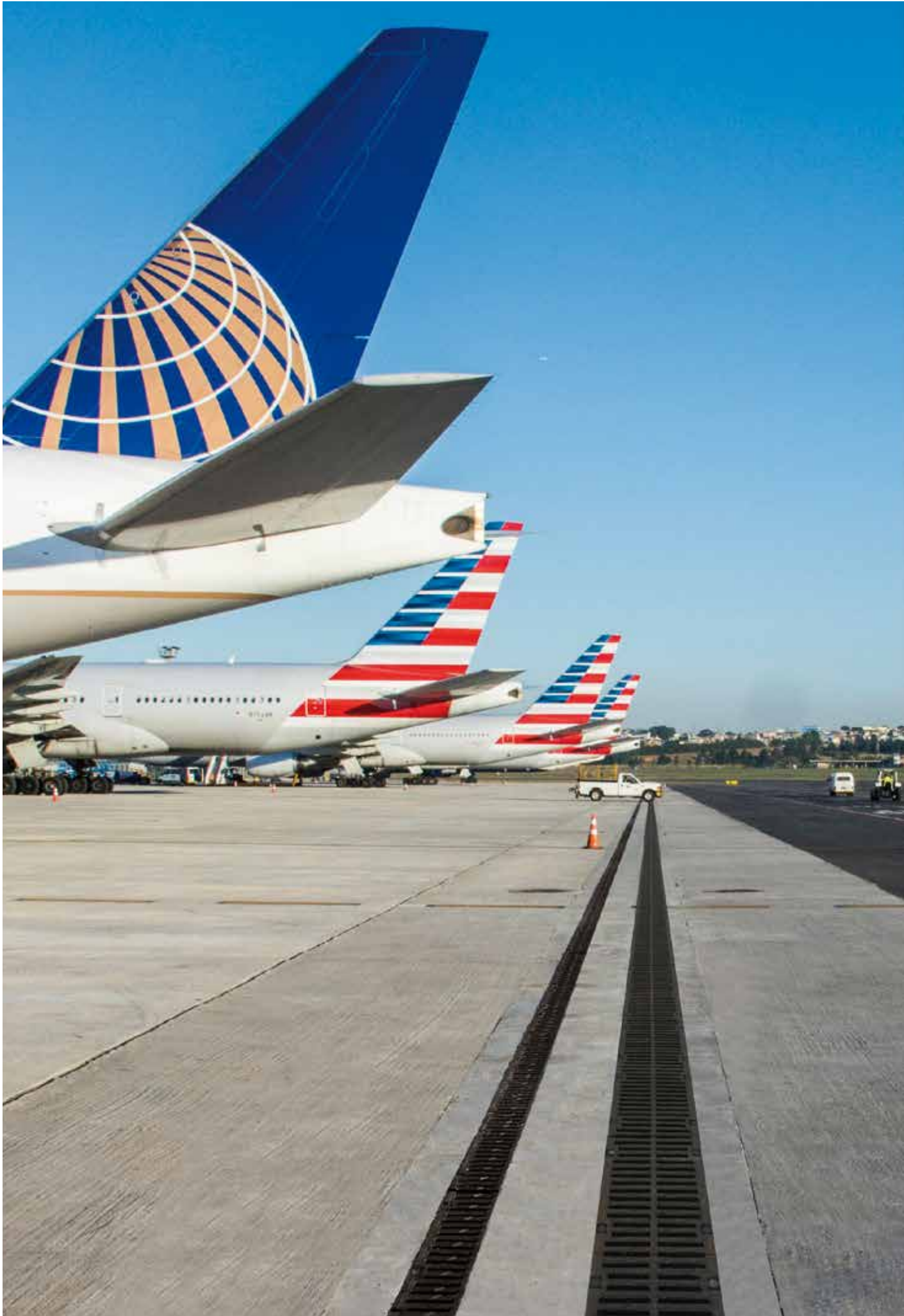

CIVIL-F

CIVIL DRAINAGE

# CIVIL-F

## SYSTEM

### Motorways and airports, loading and unloading areas, ports...

Channels with attachment of the grating to the channel with 4 screws per grating, designed for heavy traffic areas and especially for sections where the grating is subject to large axial forces due to the manoeuvring and braking of vehicles, such as service stations, loading and unloading areas in ports and warehouses, airports, public roads, car parks for heavy vehicles, etc.

The channels are reinforced with galvanised steel profiles at the sides. It is possible to incorporate a continuous 2.5% slope and or cascaded slope.

Available with modular cast iron grating with a load class of up to F900.

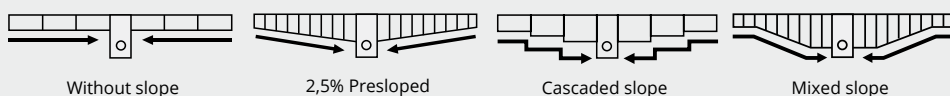
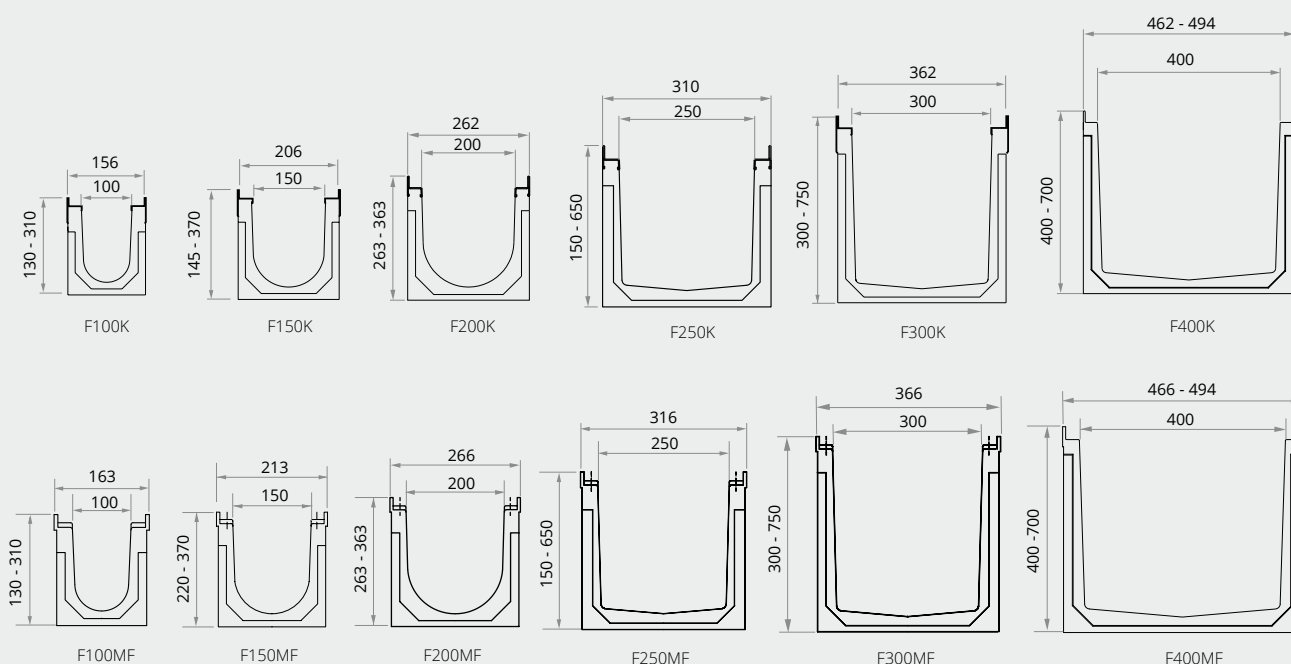

Without slope

2,5% Presloped

Cascaded slope

Mixed slope

F100  
F150  
F200  
F250  
F300  
F400

F150  
F250

F100  
F150  
F200  
F250  
F300

F150  
F250

Load Class  
up to F900  
EN-1433 Standard

# F100K



ULMA Linear Drainage Channel type F100K: External width 156 mm; Internal width 100 mm; Available with overall heights between 130 mm and 310 mm. Suitable for cascaded type slope to collect rainwater in 1 metre long units. Safe locking system consists of eight bolts per LM; Integrated galvanised steel edges for lateral protection.

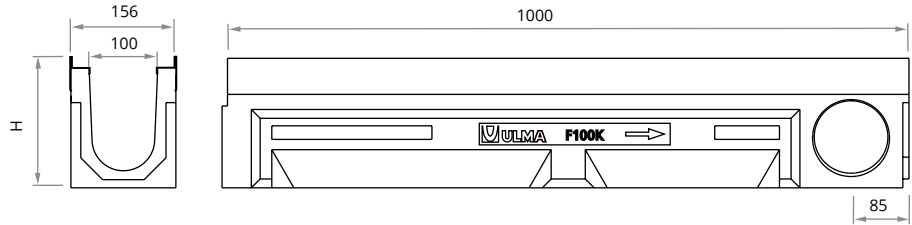

## CHANNELS

Code Channel	L mm	H mm	Width mm		Ø Outlet* mm		Hydraul. Section cm <sup>2</sup>	Pcs. pallet	Weight Kg	Qref l/s
			Ext.	Int.	Vert.	Hor.				
F100K00R	1000	130	156	100	110	-	70	49	20,0	1,26
F100K00R	1000	190	156	100	110	110	126	52	26,7	5,55
F100K10R	1000	250	156	100	110	-	184	39	28,9	9,96
F100K20R	1000	310	156	100	110	110	242	39	34,2	15,19

\* Vert. and horiz. outlets on order

## GRATINGS



Material	Design	Load	Code	L mm	Width mm	Opening mm	Weight Kg	Intake area cm <sup>2</sup> /ml	HOW TO FIX	
									Code	Units ml
DUCTILE IRON	HEELPROOF SLOTTED	D400	FNHX100FTDM	500	145	8	4,1	229	TF1023 + TP	8 + 8
	SLOTTED	E600	FNX100FTEM	500	145	19	4,0	457	TF1023 + TP	8 + 8
	CLOSED	F900	FC100FTFM	500	145	-	6,5	-	TF1023 + TP	8 + 8
	SLOTTED	F900	FNX100FTFM	500	145	19	4,4	457	TF1023 + TP	8 + 8
	HEELPROOF SLOTTED	F900	FNHX100FTFM	500	145	8	4,8	229	TF1023 + TP	8 + 8

## HOW TO FIX

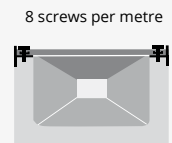

## SUMP UNITS

Code	L mm	H mm	Width mm	Lateral outlets Ø mm	Front outlet Ø mm	Sump units	Weight Kg
AF100	500	580	156	110/160	110	1	38,7

## BUCKET

Code
CU100

## STEP UNITS

Code
CEF100

To install in the changes of height with cascaded slope.

## OPEN END CAP

Channel	Code	Ø mm
F100K00R	T100F000A	110
F100K00R	T100F00A	110
F100K10R	T100F10A	110
F100K20R	T100F20A	110

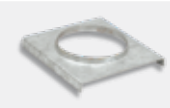

## CLOSED END CAP

Code
T100F000C
T100F00C
T100F10C
T100F20C



## SLOPE DESIGNS



Load Class  
up to F900  
EN-1433 Standard

# F100MF



ULMA Linear Drainage Channel type F100MF: External width 163 mm; Internal width 100 mm; Available with overall heights between 130 mm and 310 mm. Suitable for cascaded type slope to collect rainwater in 1 metre long units. Safe locking system consists of eight bolts per LM; Integrated galvanised steel edges for lateral protection.

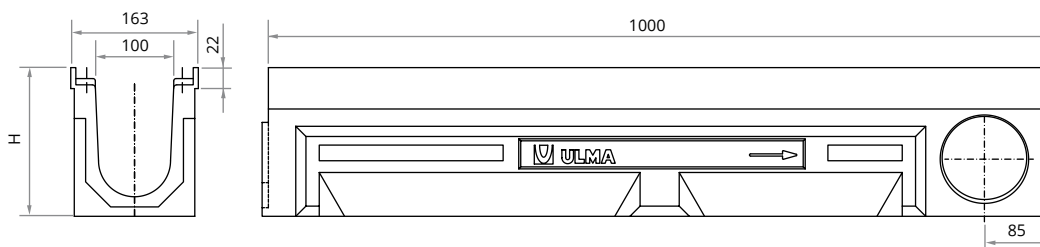

## CHANNELS

Code Channel	L mm	H mm	Width mm		Ø Outlet* mm		Hydraul. Section cm <sup>2</sup>	Pcs. pallet	Weight Kg	Qref l/s
			Ext.	Int.	Vert.	Hor.				
F100MF00R	1000	130	163	100	110	-	70	49	21,5	1,26
F100MF00R	1000	190	163	100	110	110	126	52	26,8	5,55
F100MF10R	1000	250	163	100	110	-	184	39	29,4	9,96
F100MF20R	1000	310	163	100	110	110	242	39	35,8	15,19

\* Vert. and horiz. outlets on order.

## GRATINGS



Material	Design	Load	Code	L mm	Width mm	Opening mm	Weight Kg	Intake area cm <sup>2</sup> /ml	HOW TO FIX	
									Code	Units ml
DUCTILE IRON	HEELPROOF SLOTTED	D400	FNHX100FTDM	500	145	8	4,1	229	TF1023 + TP	8 + 8
	SLOTTED	E600	FNX100FTEM	500	145	19	4,0	457	TF1023 + TP	8 + 8
	CLOSED	F900	FC100FTFM	500	145	-	6,5	-	TF1023 + TP	8 + 8
	SLOTTED	F900	FNX100FTFM	500	145	19	4,4	457	TF1023 + TP	8 + 8
	HEELPROOF SLOTTED	F900	FNHX100FTFM	500	145	8	4,8	229	TF1023 + TP	8 + 8

## HOW TO FIX



## SUMP UNITS

Code	L mm	H mm	Width mm	Lateral outlets Ø mm	Front outlet Ø mm	Sump units	Weight Kg
AMF100	500	580	163	110/160	110	1	39,4

## BUCKET

Code
CU100

## STEP UNITS

Code
CEF100

To install in the changes of height with cascaded slope.

## OPEN END CAP

Channel	Code	Ø mm
F100MF00R	T100F000A	110
F100MF00R	T100F00A	110
F100MF10R	T100F10A	110
F100MF20R	T100F20A	110

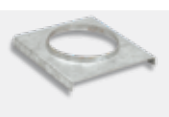

## CLOSED END CAP

Code
T100F000C
T100F00C
T100F10C
T100F20C

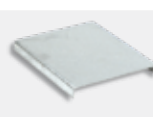

## SLOPE DESIGNS



Load Class  
up to F900  
EN-1433 Standard

# F150K

SLOPE  
**2,5%** CE

ULMA Linear Drainage Channel type F150K: External width 206 mm; Internal width 150 mm; Available with overall heights between 145 mm and 370 mm. Suitable for 2,5% presloped, cascaded or mixed slope, to collect rainwater, in 1 metre long units. Safe locking system consists of eight bolts per LM; Integrated galvanised steel\* edges for lateral protection.

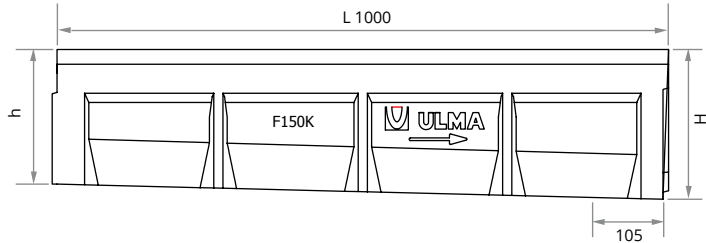
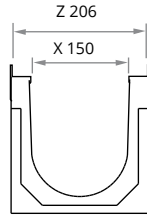

\* Also available with cast iron edges.

## CHANNELS

Code Channel	L mm	H mm		Width mm		Ø Outlet* mm		Hydraul. Section cm <sup>2</sup>	Pcs. pallet	Weight Kg	Qref l/s
		h	H	Z	X	Vert.	Hor.				
F150K01M	500	145	145	212	150	-	-	120	-	14,1	-
F150K02	1000	145	170	206	150	-	-	155	-	28,3	-
F150K03	1000	170	195	206	150	-	-	190	-	30,4	-
F150K04	1000	195	220	206	150	-	-	230	-	32,5	-
F150K00R	1000	220	220	206	160	160	-	230	45	29,4	11,59
F150K05	1000	220	245	206	150	-	-	265	-	34,6	-
F150K06	1000	245	270	206	150	-	-	305	-	36,7	-
F150K10R	1000	270	270	206	150	160	-	305	36	33,4	17,83
F150K07	1000	270	295	206	150	-	-	340	-	38,8	-
F150K08	1000	295	320	206	150	-	-	375	-	40,8	-
F150K20R	1000	320	320	206	150	160	160	375	27	41,5	24,96
F150K09	1000	320	345	206	150	-	-	410	-	42,9	-
F150K10	1000	345	370	206	150	-	-	457	-	45,0	-
F150K30R	1000	370	370	206	150	160	-	457	27	43,9	33,26

\* Vert. and horiz. outlets on order .

## GRATINGS



Material	Design	Load	Code	L mm	Width mm	Opening mm	Weight Kg	Intake area cm <sup>2</sup> /ml
DUCTILE IRON	SLOTTED	D400	FNX150FTDM	500	195	13,75	6,2	672
	HEELPROOF SLOTTED	D400	FNHX150FTDM	500	195	8	6,3	364
	SLOTTED	E600	FNX150FTEM	500	195	19	7,0	672
	SLOTTED	F900	FNX150FTFM	500	195	19	7,3	723
	HEELPROOF SLOTTED	F900	FNHX150FTFM	500	195	8	8,5	364
	CLOSED	F900	FC150FTFM	500	195	-	12,2	-
DUCTILE IRON STAINLESS	SLOTTED	D400	FIN150FTDM	500	195	25	8,9	566

## HOW TO FIX

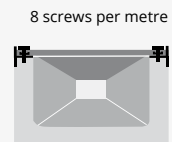

Code	Units ml
TF1023 + TP	8 + 8
TF1023 + TP	8 + 8
TF1023 + TP	8 + 8
TF1023 + TP	8 + 8
TF1023 + TP	8 + 8
TF1023 + TP	8 + 8
TFX1020	8

## CONTINUOUS PRESLOPED OF 2,5%

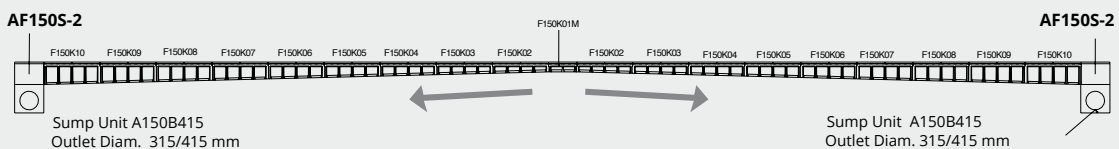

**FIRST POLYMER CONCRETE CHANNEL WITH PRESLOPED OF 2,5% ON THE MARKET**

- High hydraulic capacity.
- Self-cleaning effect.
- Minimum maintenance.

# F150K

## SUMP UNITS



Code	L mm	H mm	Width mm	Lateral outlets Ø mm	Front outlet Ø mm	Sump units	Weight Kg
AF150-2	500	402	206	160/200	-	1	33,3
AF150S-2 + A150B415	500	918**	206	315/415	-	2	73,2
AF150 *	500	350	206	160	110	1	24,9
AF150S + A150B **	500	655**	206	160	110	2	46,9

\*Available up to 320 mm height.

\*\*The sump unit can be higher incorporating an intermediate unit.

## BUCKET

Code**
-
C150
-
C150

\*\* Only applicable if 2 sump units are installed.

## OPEN END CAP

Channel	Code	Ø mm
F150K00R	T150K00A	160
F150K10R	T150K10A	160
F150K20R	T150K20A	160
F150K30R	T150K30A	160

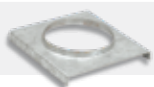

## CLOSED END CAP

Code
T150K00C
T150K10C
T150K20C
T150K30C

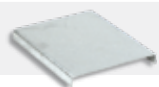

## STEP UNITS

Code
CE150



To install in the changes of height with cascaded slope.

## SLOPE DESIGNS

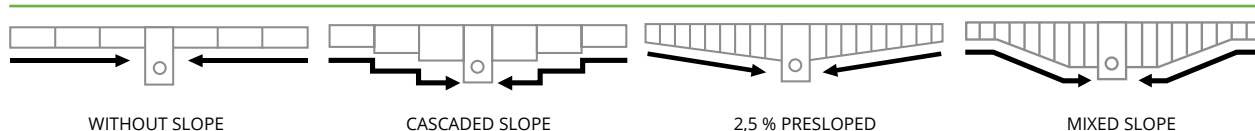

**Load Class**  
up to F900  
EN-1433 Standard

# F150MF



ULMA Linear Drainage Channel type F150MF: External width 213 mm; Internal width 150 mm; Available with overall heights between 220 mm and 370 mm. Suitable for cascaded slope, to collect rainwater, in 1 metre long units. Safe locking system consists of eight bolts per LM; Integrated galvanised steel\* edges for lateral protection.

\* Also available with cast iron edges.

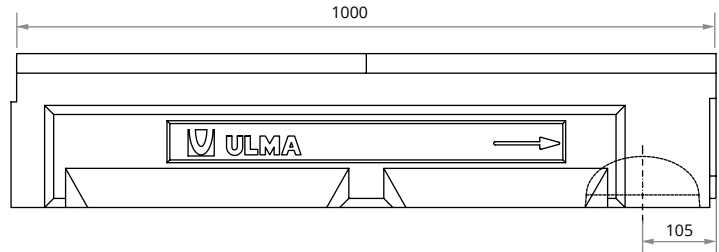
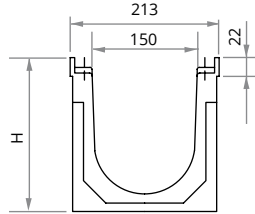

## CHANNELS

Code Channel	L mm	H mm	Width mm		Ø Outlet* mm		Hydraul. Section cm <sup>2</sup>	Pcs. pallet	Weight Kg	Qref l/s
			Z	X	Vert.	Hor.				
F150MF00R	1000	220	213	160	160	-	230	45	33,2	11,59
F150MF10R	1000	270	213	150	160	-	305	36	34,3	17,83
F150MF20R	1000	320	213	150	160	160	375	27	41,4	24,96
F150MF30R	1000	370	213	150	160	-	457	27	47,4	33,26

\* Vert. and horiz. outlets on order .

## GRATINGS

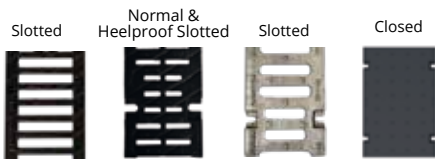

Material	Design	Load	Code	L mm	Width mm	Opening mm	Weight Kg	Intake area cm <sup>2</sup> /ml
DUCTILE IRON	SLOTTED	D400	FNX150FTDM	500	195	13,75	6,2	672
	HEELPROOF SLOTTED	D400	FNHX150FTDM	500	195	8	6,3	364
	SLOTTED	E600	FNX150FTEM	500	195	19	7,0	672
	SLOTTED	F900	FNX150FTFM	500	195	19	7,3	723
	HEELPROOF SLOTTED	F900	FNHX150FTFM	500	195	8	8,5	364
DUCTILE IRON STAINLESS	CLOSED	F900	FC150FTFM	500	195	-	12,2	-
	SLOTTED	D400	FIN150FTDM	500	195	25	8,9	566

## HOW TO FIX

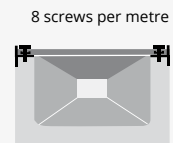

Code	Units ml
TF1023 + TP	8 + 8
TF1023 + TP	8 + 8
TF1023 + TP	8 + 8
TF1023 + TP	8 + 8
TF1023 + TP	8 + 8
TF1023 + TP	8 + 8
TFX1020	8

## SUMP UNITS

Code	L mm	H mm	Width mm	Lateral outlets Ø mm	Front outlet Ø mm	Sump units	Weight Kg
AMF150-2	500	402	213	160/200	-	1	34,0
AMF150-2 + A150B415	500	918**	213	315/415	-	2	75,8
AMF150*	500	350	213	160	110	1	22,3
AMF150S + A150B**	500	655**	213	160	110	2	46,3

\*Available up to 320 mm height.

\*\*The sump unit can be higher incorporating an intermediate unit.

## BUCKET

Code**
-
C150
-
C150

\*\* Only applicable if 2 sump units are installed.

# F150MF

## OPEN END CAP

Channel	Code	Ø mm
F150K00R	T150K00A	160
F150K10R	T150K10A	160
F150K20R	T150K20A	160
F150K30R	T150K30A	160

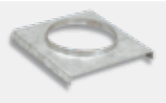

## CLOSED END CAP

Code
T150K00C
T150K10C
T150K20C
T150K30C

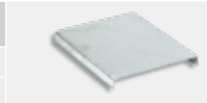

## STEP UNITS

Code
CE150



To install in the changes of height with cascaded slope.

## SLOPE DESIGNS

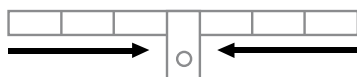

WITHOUT SLOPE

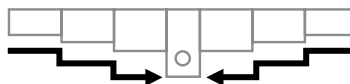

CASCADED SLOPE





**Load Class  
up to F900**  
EN-1433 Standard

# F200K



ULMA Linear Drainage Channel type F200K: External width 262 mm; Internal width 200 mm; Available with overall heights between 263 mm and 363 mm. Suitable for cascaded type slope to collect rainwater in 1 metre long units. Safe locking system consists of eight bolts per LM; Integrated galvanised steel edges for lateral protection.

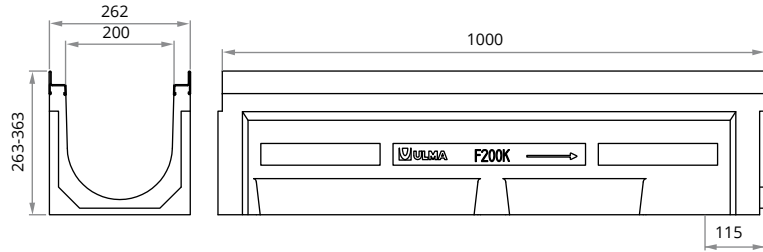

## CHANNELS

Code Channel	L mm	H mm	Width mm		Ø Outlet* mm		Hydraul. Section cm <sup>2</sup>	Pcs. pallet	Weight Kg	Qref l/s
			Ext.	Int.	Vert.	Hor.				
F200K00R	1000	263	262	200	160	-	374	28	43,8	21,37
F200K10R	1000	313	262	200	160	160	473	21	48,0	30,75
F200K20R	1000	363	262	200	160	160	571	21	53,8	41,49

\* Vert. and horiz. outlets on order.

## GRATINGS

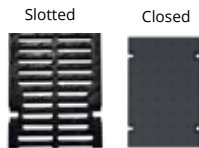

Material	Design	Load	Code	L mm	Width mm	Opening mm	Weight Kg	Intake area cm <sup>2</sup> /ml	HOW TO FIX	
									Code	Units ml
DUCTILE IRON	SLOTTED	D400	FNX200FTDM	500	251	13,75	8,3	552	TF1023 + TP	8 + 8
	SLOTTED	E600	FNX200FTEM	500	251	13,75	10,1	552	TF1023 + TP	8 + 8
	SLOTTED	F900	FNX200FTFM	500	251	19	10,1	920	TF1023 + TP	8 + 8
	CLOSED	F900	FC200FTFM	500	251	-	13,3	-	TF1023 + TP	8 + 8

## HOW TO FIX

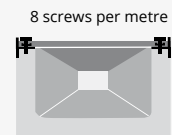

## SUMP UNITS

Code	L mm	H mm	Width mm	Lateral outlets Ø mm	Front outlet Ø mm	Sump units	Weight Kg
AF200	500	363	262	160/200	-	1	34,4
AF200S + A200B	500	705*	262	160/200	-	2	53,5

\* The sump unit can be higher incorporating an intermediate unit.

## BUCKET

Code**
C200

\*\* Only applicable if 2 sump units are installed.

## OPEN END CAP

Channel	Code	Ø mm
F200K00R	T200K00A	200
F200K10R	T200K10A	200
F200K20R	T200K20A	200

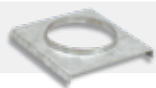

## CLOSED END CAP

Code
T200K00C
T200K10C
T200K20C

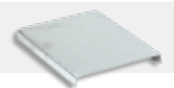

## STEP UNITS

Code
CE200



To install in the changes of height with cascaded slope.

## SLOPE DESIGNS



**Load Class  
up to F900**  
EN-1433 Standard

# F200MF

CE

ULMA Linear Drainage Channel type F200MF: External width 266 mm; Internal width 200 mm; Available with overall heights between 263 mm and 363 mm. Suitable for cascaded type slope to collect rainwater in 1 metre long units. Safe locking system consists of eight bolts per LM; Integrated galvanised steel edges for lateral protection.

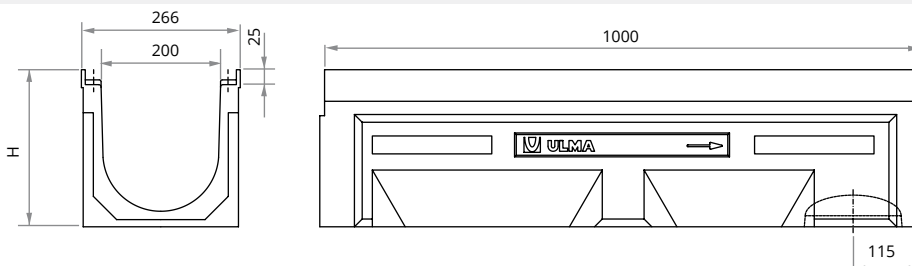

## CHANNELS

Code Channel	L mm	H mm	Width mm		Ø Outlet* mm		Hydraul. Section cm <sup>2</sup>	Pcs. pallet	Weight Kg	Qref l/s
			Ext.	Int.	Vert.	Hor.				
F200MF00R	1000	263	266	200	160	-	374	28	42,4	21,37
F200MF10R	1000	313	266	200	160	160	473	21	49,7	30,75
F200MF20R	1000	363	266	200	160	160	571	21	55,8	41,49

\* Vert. and horiz. outlets on order.

## GRATINGS

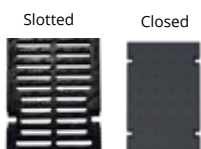

Material	Design	Load	Code	L mm	Width mm	Opening mm	Weight Kg	Intake area cm <sup>2</sup> /ml
DUCTILE IRON	SLOTTED	D400	FNX200FTDM	500	251	13,75	8,3	552
	SLOTTED	E600	FNX200FTEM	500	251	13,75	10,1	552
	SLOTTED	F900	FNX200FTFM	500	251	19	10,1	920
	CLOSED	F900	FC200FTFM	500	251	-	13,3	-

## HOW TO FIX

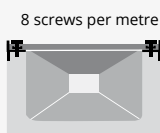

Code	Units ml
TF1023 + TP	8 + 8
TF1023 + TP	8 + 8
TF1023 + TP	8 + 8
TF1023 + TP	8 + 8

## SUMP UNITS



Code	L mm	H mm	Width mm	Lateral outlets Ø mm	Front outlet Ø mm	Sump units	Weight Kg
AMF200	500	363	266	160/200	-	1	35,3
AMF200S + A200B	500	705*	266	160/200	-	2	56,4

\* The sump unit can be higher incorporating an intermediate unit.

## BUCKET



Code\*\*  
C200

\*\* Only applicable if 2 sump units are installed.

## OPEN END CAP

Channel	Code	Ø mm
F200MF00R	T200K00A	200
F200MF10R	T200K10A	200
F200MF20R	T200K20A	200

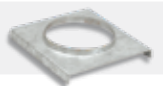

## CLOSED END CAP

Code
T200K00C
T200K10C
T200K20C

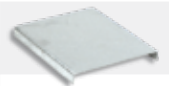

## STEP UNITS

Code
CE200



To install in the changes of height with cascaded slope.

## SLOPE DESIGNS

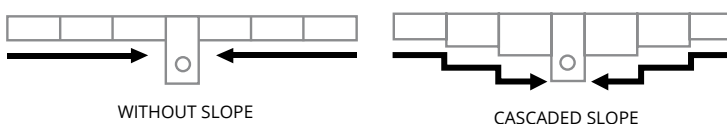

Load Class  
up to F900  
EN-1433 Standard

# F250K

SLOPE  
**2,5%** CE

ULMA Linear Drainage Channel type F250K: External width 312 mm; Internal width 250 mm; Available with overall heights between 150 mm and 650 mm. Suitable for 2,5% presloped, cascaded or mixed slope, to collect rainwater in 1 metre long units. Safe locking system consists of eight bolts per LM; Integrated galvanised steel\* edges for lateral protection.

\* Also available with cast iron edges.

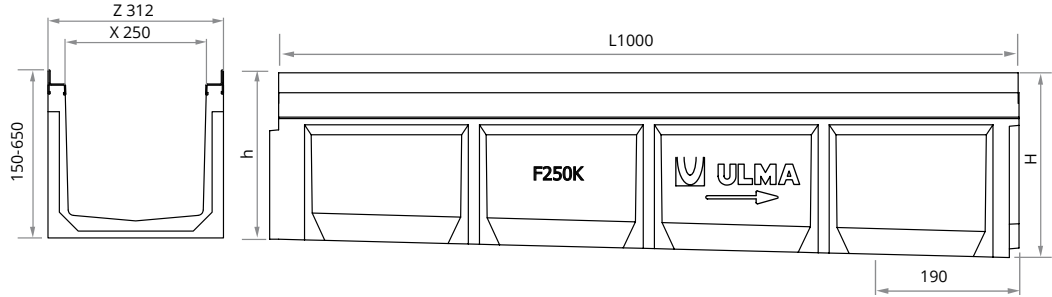

## CHANNELS

Code Channel	L mm	H mm		Width mm		Ø Outlet* mm		Hydraul. Section cm <sup>2</sup>	Pcs. pallet	Weight Kg	Qref l/s
		h	H	Z	X	Vert.	Hor.				
F250K01RM	500	150	150	312	250	-	-	220	-	19,8	-
F250K01	1000	150	175	312	250	-	-	280	-	34,4	-
F250K02	1000	175	200	312	250	-	-	340	-	38,1	-
F250K03	1000	200	225	312	250	-	-	400	-	40,7	-
F250K04	1000	225	250	312	250	-	-	460	-	42,3	-
F250K05	1000	250	275	312	250	-	-	520	-	44,3	-
F250K06	1000	275	300	312	250	-	-	580	-	46,8	-
F250K00R	1000	300	300	312	250	250	200	580	28	47,1	38,57
F250K07	1000	300	325	312	250	-	-	640	-	48,2	-
F250K08	1000	325	350	312	250	-	-	700	-	52,8	-
F250K10R	1000	350	350	312	250	250	200	700	28	49,6	51,52
F250K09	1000	350	375	312	250	-	-	760	-	55,1	-
F250K10	1000	375	400	312	250	-	-	820	-	57,7	-
F250K20R	1000	400	400	312	250	250	200	820	21	55,0	65,68
F250K11	1000	400	425	312	250	-	-	870	-	69,6	-
F250K12	1000	425	450	312	250	-	-	930	-	73,3	-
F250K30R	1000	450	450	312	250	-	-	935	14	63,2	80,98
F250K13	1000	450	475	312	250	-	-	985	-	77,5	-
F250K14	1000	475	500	312	250	-	-	1045	-	79,8	-
F250K15	1000	500	525	312	250	-	-	1100	-	83,7	-
F250K16	1000	525	550	312	250	-	-	1160	-	87,9	-
F250K17	1000	550	575	312	250	-	-	1215	-	90,0	-
F250K18	1000	575	600	312	250	-	-	1270	-	94,2	-
F250K19	1000	600	625	312	250	-	-	1320	-	98,4	-
F250K20	1000	625	650	312	250	-	-	1380	-	103,6	-
F250K40R	1000	650	650	312	250	250	-	1383	8	91,1	151,7

\* Vert. outlets on order.

## CONTINUOUS PRESLOPED OF 2,5%

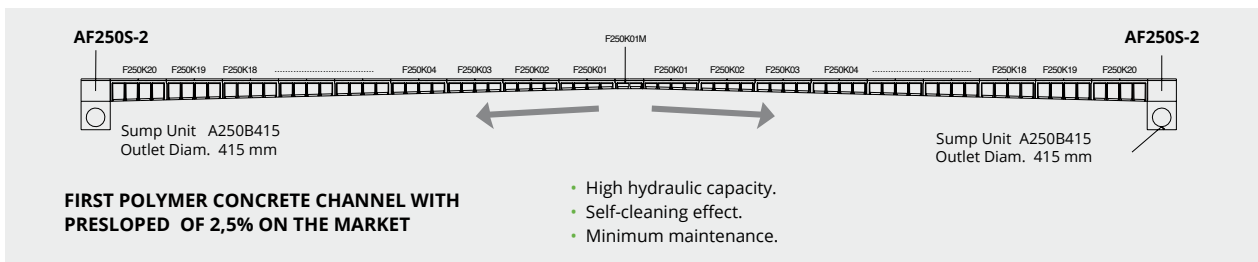

**FIRST POLYMER CONCRETE CHANNEL WITH PRESLOPED OF 2,5% ON THE MARKET**

- High hydraulic capacity.
- Self-cleaning effect.
- Minimum maintenance.

# F250K

## GRATINGS

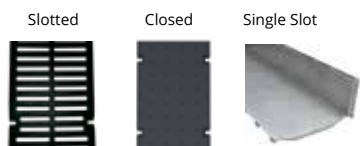

Material	Design	Load	Code	L mm	Width mm	Opening mm	Weight Kg	Intake area cm <sup>2</sup> /ml
DUCTILE IRON	SLOTTED	C250	FNX250FTCM	500	301	13,75	11,3	1146
	SLOTTED	D400	FNX250FTDM	500	301	13,75	13,2	1146
	SLOTTED	F900	FNX250FTFM	500	301	19	20,4	1185
	CLOSED	F900	FC250FTFM	500	301	-	23,9	-
GALVANISED STEEL	SINGLE SLOT	D400	GRL250FOD	1000	301	18 / H150	22,9	180

## HOW TO FIX

8 screws per metre



Code	Units ml
TF1023 + TP	8 + 8
TF1023 + TP	8 + 8
TF1023 + TP	8 + 8
TF1023 + TP	8 + 8
(1)	(1)

(1) Click. Without screws.

## SUMP UNITS



Code	L mm	H mm	Width mm	Lateral outlets Ø mm	Front outlet Ø mm	Sump units	Weight Kg
AF250*	500	400	316	160/200	-	1	38,6
AF250-65	500	680	312	415	-	1	67,4
AF250S + A250B**	500	750*	316	160/200	-	2	88,8
AF250S - 65 + A250B415	500	1183*	316	415	200	2	133,7
F250K40RS+ A250B415	1000	1155	316	415	200	2	116,5

\* The sump unit can be higher incorporating an intermediate unit.

\*\* Available up to 400 mm height.

## BUCKET



\*\* Only applicable if 2 sump units are installed.

## OPEN END CAP

Channel	Code	Ø mm
F250K00R	T250K00A	200
F250K10R	T250K10A	200
F250K20R	T250K20A	200
F250K30R	T250K30A	200
F250K40R	T250K40A	200

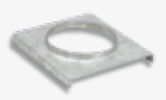

## CLOSED END CAP

Code
T250K00C
T250K10C
T250K20C
T250K30C
T250K40C

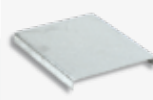

## STEP UNITS

Code
CE250



To install in the changes of height with cascaded slope.

## SLOPE DESIGNS

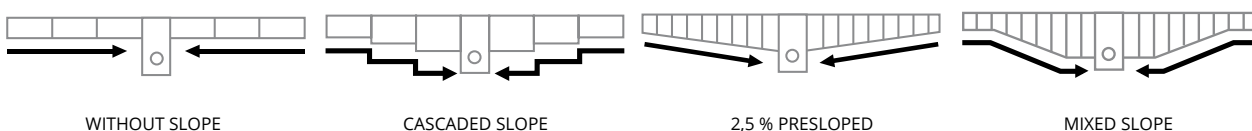

WITHOUT SLOPE

CASCADED SLOPE

2,5 % PRESLOPED

MIXED SLOPE

Load Class  
up to F900  
EN-1433 Standard

# F250MF



ULMA Linear Drainage Channel type F250MF: External width 316 mm; Internal width 250 mm; Available with overall heights between 150 mm and 650 mm. Suitable for cascaded slope, to collect rainwater in 1 metre long units. Safe locking system consists of eight bolts per LM; Integrated galvanised steel edges for lateral protection.

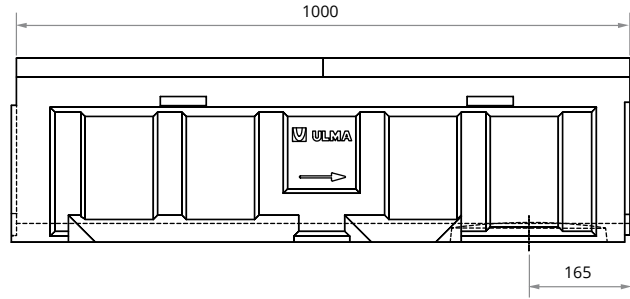
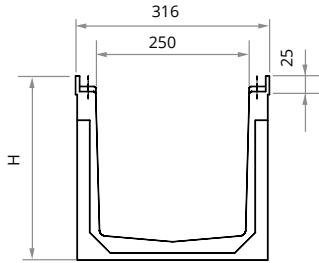

## CHANNELS

Code Channel	L mm	H mm	Width mm		Ø Outlet* mm		Hydraul. Section cm <sup>2</sup>	Pcs. pallet	Weight Kg	Qref l/s
			Z	X	Vert.	Hor.				
F250MF01RM	500	150	316	250	-	-	220	-	20,6	-
F250MF00R	1000	300	316	250	250	-	580	28	50,4	38,57
F250MF10R	1000	350	316	250	250	-	700	28	54,6	51,52
F250MF20R	1000	400	316	250	250	-	820	21	59,0	65,68
F250MF30R	1000	450	316	250	-	-	935	14	64,8	80,98
F250MF40R	1000	650	316	250	250	-	1383	8	84,6	151,7

\* \*Vert. outlets on order.

## GRATINGS

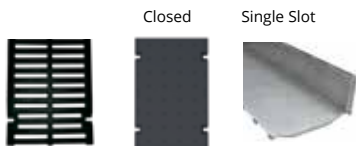

Material	Design	Load	Code	L mm	Width mm	Opening mm	Weight Kg	Intake area cm <sup>2</sup> /ml
DUCTILE IRON	SLOTTED	C250	FNX250FTCM	500	301	13,75	11,3	1146
	SLOTTED	D400	FNX250FTDM	500	301	13,75	13,2	1146
	SLOTTED	F900	FNX250FTFM	500	301	19	20,4	1185
	CLOSED	F900	FC250FTFM	500	301	-	23,9	-
GALVANISED STEEL	SINGLE SLOT	D400	GRL250FOD	1000	301	18 / H150	22,9	180

## HOW TO FIX

8 screws per metre



Code	Units ml
TF1023 + TP	8 + 8
TF1023 + TP	8 + 8
TF1023 + TP	8 + 8
TF1023 + TP	8 + 8
(1)	(1)

(1) Click. Without screws.

## SUMP UNITS

Code	L mm	H mm	Width mm	Lateral outlets Ø mm	Front outlet Ø mm	Sump units	Weight Kg
AMF250*	500	400	316	160/200	-	1	39,4
AMF250-65	500	680	316	415	-	1	74,9
AMF250S + A250B**	500	750*	316	160/200	-	2	68,2
F250MF40RS+ A250B415	1000	1155	316	415	200	2	129,5

\* The sump unit can be higher incorporating an intermediate unit.

\*\* Available up to 400 mm height.

## BUCKET

Code**
C250

\*\* Only applicable if 2 sump units are installed.

# F250MF

## OPEN END CAP

Channel	Code	Ø mm
F250MF00R	T250K00A	200
F250MF10R	T250K10A	200
F250MF20R	T250K20A	200
F250MF30R	T250K30A	200
F250MF40R	T250K40A	200

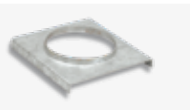

## CLOSED END CAP

Code
T250K00C
T250K10C
T250K20C
T250K30C
T250K40C



## STEP UNITS

Code
CE250



To install in the changes of height with cascaded slope.

## SLOPE DESIGNS



WITHOUT SLOPE

CASCADED SLOPE



Load Class  
up to F900  
EN-1433 Standard

# F300K



ULMA Linear Drainage Channel type F300K: External width 362 mm; Internal width 300 mm; Available with overall heights between 300 mm and 750 mm. Suitable for cascaded type slope to collect rainwater in 1 metre long units. Safe locking system consists of eight bolts per LM; Integrated galvanised steel edges for lateral protection.

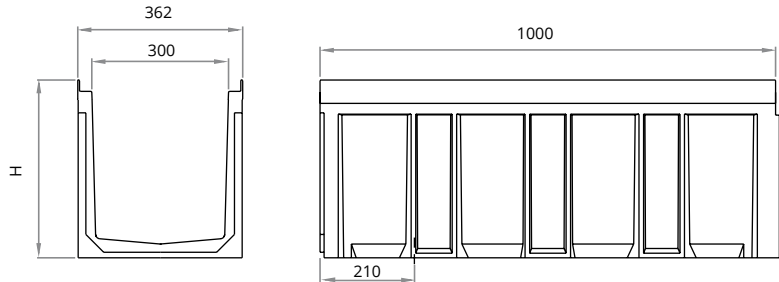

## CHANNELS

Code Channel	L mm	H mm	Width mm		Ø Outlet* mm		Hydraul. Section cm <sup>2</sup>	Pcs. pallet	Weight Kg	Qref l/s
			Ext.	Int.	Vert.	Hor.				
F300K00R	1000	300	362	300	250	-	710	15	54,3	46,44
F300K00R	1000	390	362	300	200	-	975	9	62,0	77,50
F300K10R	1000	440	362	300	200	-	1110	9	70,4	94,20
F300K20R	1000	490	362	300	200	-	1240	9	75,9	113,89
F300K60R	1000	600	362	300	-	-	1525	9	96,1	163,86
F300K75R	1000	750	394	300	-	-	1933	4	112,0	230,23

\* Vert. outlets on order.

## GRATINGS

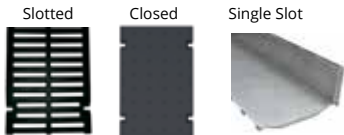

Material	Design	Load	Code	L mm	Width mm	Opening mm	Weight Kg	Intake area cm <sup>2</sup> /ml
DUCTILE IRON	SLOTTED	C250	FNX300FTCM	500	351	17,75	13,2	1351
	SLOTTED	D400	FNX300FTDM	500	351	13,75	17,8	1340
	SLOTTED	F900	FNX300FTFM	500	351	14	27,1	1371
	CLOSED	D400	FC300FTDM	500	351	-	16,3	-
	CLOSED	F900	FC300FTFM	500	351	-	29,4	-
GALVANISED STEEL	SINGLE SLOT	D400	GRL300FOD	1000	351	18 / H150	26,0	180

## HOW TO FIX

8 screws per metre



Code	Units ml
TF1023 + TP	8 + 8
TF1023 + TP	8 + 8
TF1023 + TP	8 + 8
TF1023 + TP	8 + 8
TF1023 + TP	8 + 8
(1)	(1)

(1) Click. Without screws.

## SUMP UNITS

Code	L mm	H mm	Width mm	Lateral outlets Ø mm	Front outlet Ø mm	Sump units	Weight Kg
AF300 *	500	390	362	200	-	1	42,8
AF300S + A300B **	500	730**	362	200	-	2	71,0
F300K60RS + UNIS60**	1000	1148**	362	200/400	200	2	120,2
F300K75RS + UNIS60**	1000	1298**	362	200/400	200	2	136,5

\* Available up to 390 mm height. (F300K00R)

\*\* The sump unit can be higher incorporating an intermediate unit.

## BUCKET

Code**
C250

\*\* Only applicable if 2 sump units are installed.

## OPEN END CAP

Channel	Code	Ø mm
F300K00R	T300K00A	315
F300K00R	T300K00A	315
F300K10R	T300K10A	315
F300K20R	T300K20A	315
F300K60R	T300K60A	315

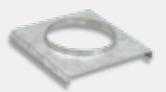

## CLOSED END CAP

Code
T300K00C
T300K00C
T300K10C
T300K20C
T300K60C

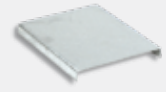

## STEP UNITS

Code
CE300



To install in the changes of height with cascaded slope.

## SLOPE DESIGNS

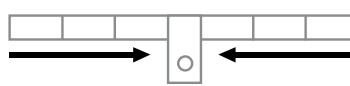

WITHOUT SLOPE

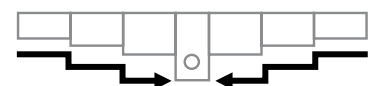

CASCADED SLOPE

**Load Class**  
up to F900  
EN-1433 Standard

# F300MF



ULMA Linear Drainage Channel type F300MF: External width 366 mm; Internal width 300 mm; Available with overall heights between 300 mm and 750 mm. Suitable for cascaded type slope to collect rainwater in 1 metre long units. Safe locking system consists of eight bolts per LM; Integrated galvanised steel edges for lateral protection.

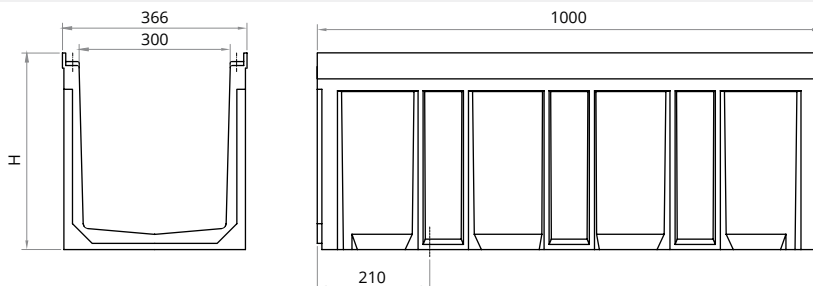

## CHANNELS

Code Channel	L mm	H mm	Width mm		Ø Outlet* mm		Hydraul. Section cm²	Pcs. pallet	Weight Kg	Qref l/s
			Ext.	Int.	Vert.	Hor.				
F300MF00R	1000	300	366	300	250	-	710	15	56,0	46,44
F300MF00R	1000	390	366	300	200	-	975	15	62,2	77,50
F300MF10R	1000	440	366	300	200	-	1110	10	69,7	94,20
F300MF20R	1000	490	366	300	200	-	1240	10	77,6	113,89
F300MF60R	1000	600	366	300	-	-	1525	6	97,8	163,86
F300MFH75R	1000	750	394	300	-	-	1933	4	115,5	230,23

\* Vert. outlets on order.

## GRATINGS

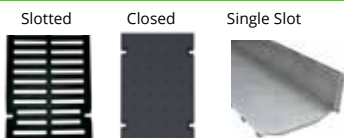

Material	Design	Load	Code	L mm	Width mm	Opening mm	Weight Kg	Intake area cm²/ml
DUCTILE IRON	SLOTTED	C250	FNX300FTCM	500	351	17,75	13,2	1351
	SLOTTED	D400	FNX300FTDM	500	351	13,75	17,8	1340
	SLOTTED	F900	FNX300FTFM	500	351	14	27,1	1371
	CLOSED	D400	FC300FTDM	500	351	-	16,3	-
	CLOSED	F900	FC300FTFM	500	351	-	29,4	-
GALVANISED STEEL	SINGLE SLOT	D400	GRL300FOD	1000	351	18 / H150	26,0	180

## HOW TO FIX

8 screws per metre



Code	Units ml
TF1023 + TP	8 + 8
TF1023 + TP	8 + 8
TF1023 + TP	8 + 8
TF1023 + TP	8 + 8
TF1023 + TP	8 + 8
(1)	(1)

(1) Click. Without screws.

## BUCKET

Code**
C250

\*\* Only applicable if 2 sump units are installed.

## SUMP UNITS

Code	L mm	H mm	Width mm	Lateral outlets Ø mm	Front outlet Ø mm	Sump units	Weight Kg
AMF300 *	500	390	366	200	-	1	43,6
AMF300S + A300B **	500	730**	366	200	-	2	71,8
F300MF60RS UNI560**	1000	1148**	366	200/400	200	2	120,3
F300MF75RS UNI560**	1000	1298**	394	200/400	200	2	136,5

\* Available up to 390 mm height. (F300MF00R)

\*\* The sump unit can be higher incorporating an intermediate unit.

## OPEN END CAP

Channel	Code	Ø mm
F300MF00R	T300K000A	315
F300MF00R	T300K00A	315
F300MF10R	T300K10A	315
F300MF20R	T300K20A	315
F300MF60R	T300K60A	315

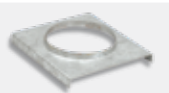

## CLOSED END CAP

Code
T300K000C
T300K00C
T300K10C
T300K20C
T300K60C

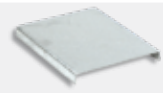

## STEP UNITS

Code
CE300



To install in the changes of height with cascaded slope.

## SLOPE DESIGNS

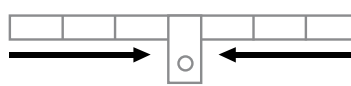

WITHOUT SLOPE

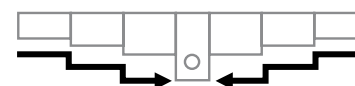

CASCADED SLOPE



Load Class  
up to F900  
EN-1433 Standard

# F400K



ULMA Linear Drainage Channel type F400K: External width between 462 mm and 494 mm; Internal width 400 mm; Available with overall heights between 400 mm and 700 mm to collect rainwater in 1 metre long units. Safe locking system consists of eight bolts per LM; Integrated galvanised steel edges for lateral protection.

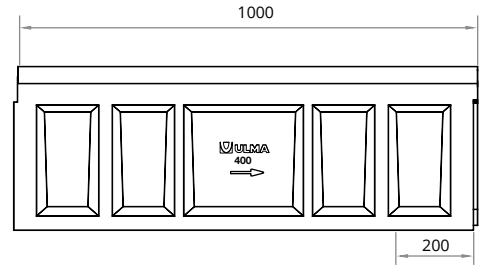
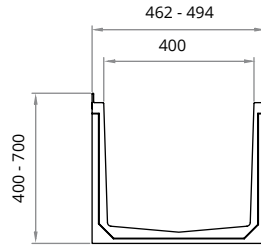

## CHANNELS

Code Channel	L mm	H mm	Width mm		Ø Outlet* mm		Hydraul. Section cm <sup>2</sup>	Pcs. pallet	Weight Kg	Qref l/s
			Ext.	Int.	Vert.	Hor.				
F400K00R	1000	400	462	400	315	-	1337	6	85,6	100,03
F400K40R	1000	700	494	400	315	-	2490	4	129,1	280,50

\*Vert. outlets on order.

## GRATINGS

Slotted



Material	Design	Load	Code	L mm	Width mm	Opening mm	Weight Kg	Intake area cm <sup>2</sup> /ml
DUCTILE IRON	SLOTTED	D400	FNX400FTDM	500	451	18,5	25,8	1604
	SLOTTED	F900	FNX400FTFM	500	451	18,5	30,3	1615

## HOW TO FIX

8 screws per metre



Code	Units ml
TF1023 + TP	8 + 8
TF1023 + TP	8 + 8

## SUMP UNITS

Code	L mm	H mm	Width mm	Lateral outlets Ø mm	Front outlet Ø mm	Sump units	Weight Kg
AF400	500	585	462	315	-	1	80,0
AF400S+ A400B*	500	1115	462	315	-	2	167,6
F400K40RS + A400B	1000	1285	494	315	-	2	211,1

\*The sump unit can be higher incorporating an intermediate unit.

## BUCKET

Code**
C400

\*\* Only applicable if 2 sump units are installed.

## OPEN END CAP

Channel	Code	Ø mm
F400K00R	T400K00A	315
F400K40R	T400K40A	315

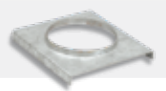

## CLOSED END CAP

Code
T400K00C
T400K40C

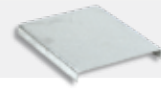

**Load Class  
up to F900**  
EN-1433 Standard

# F400MF



ULMA Linear Drainage Channel type F400MF: External width between 466 mm and 494 mm; Internal width 400 mm; Available with overall heights between 400 mm and 700 mm to collect rainwater in 1 metre long units. Safe locking system consists of eight bolts per LM; Integrated galvanised steel edges for lateral protection.

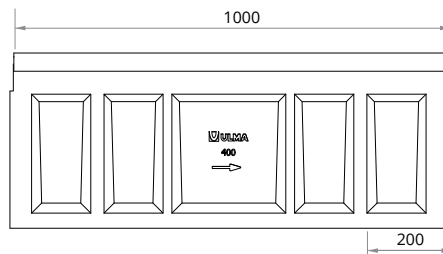
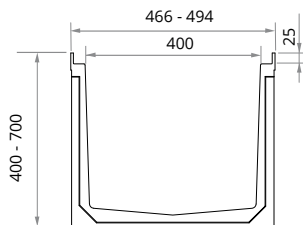

## CHANNELS

Code Channel	L mm	H mm	Width mm		Ø Outlet* mm		Hydraul. Section cm <sup>2</sup>	Pcs. pallet	Weight Kg	Qref l/s
			Ext.	Int.	Vert.	Hor.				
F400MF00R	1000	400	466	400	315	-	1337	6	87,3	100,03
F400MF40R	1000	700	494	400	315	-	2490	4	130,4	280,50

\*Vert. outlets on order.

## GRATINGS

Slotted



Material	Design	Load	Code	L mm	Width mm	Opening mm	Weight Kg	Intake area cm <sup>2</sup> /ml
DUCTILE IRON	SLOTTED	D400	FNX400FTDM	500	451	18,5	25,8	1604
	SLOTTED	F900	FNX400FTFM	500	451	18,5	30,3	1615

## HOW TO FIX

8 screws per metre



Code	Units ml
TF1023 + TP	8 + 8
TF1023 + TP	8 + 8

## SUMP UNITS

Code	L mm	H mm	Width mm	Lateral outlets Ø mm	Front outlet Ø mm	Sump units	Weight Kg
AMF400	500	585	466	315	-	1	80,8
AMF400S+ A400B*	500	1115	466	315	-	2	168,4
F400MF40RS + A400B	1000	1285	494	315	-	2	205,7

\*The sump unit can be higher incorporating an intermediate unit.

## BUCKET

Code**
C400

\*\* Only applicable if 2 sump units are installed.

## OPEN END CAP

Channel	Code	Ø mm
F400MF00R	T400K00A	315
F400MF40R	T400K40A	315

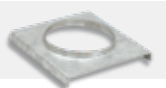

## CLOSED END CAP

Code
T400K00C
T400K40C



# SUMP UNITS

## AF100 / AMF100\*

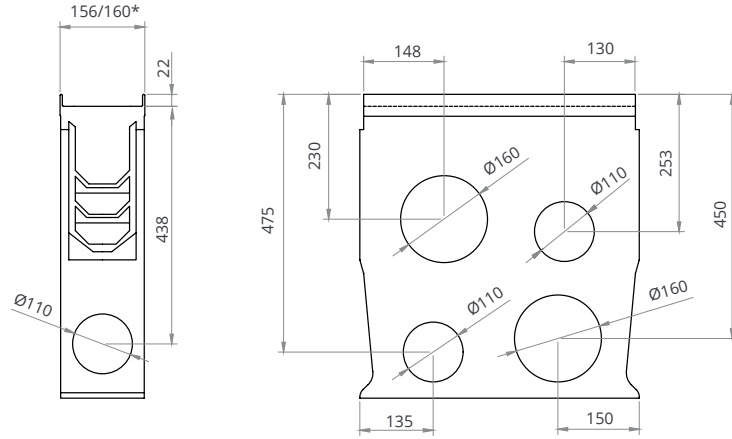

## AF150S + A150I + A150B / AMF150S + A150I + A150B\*

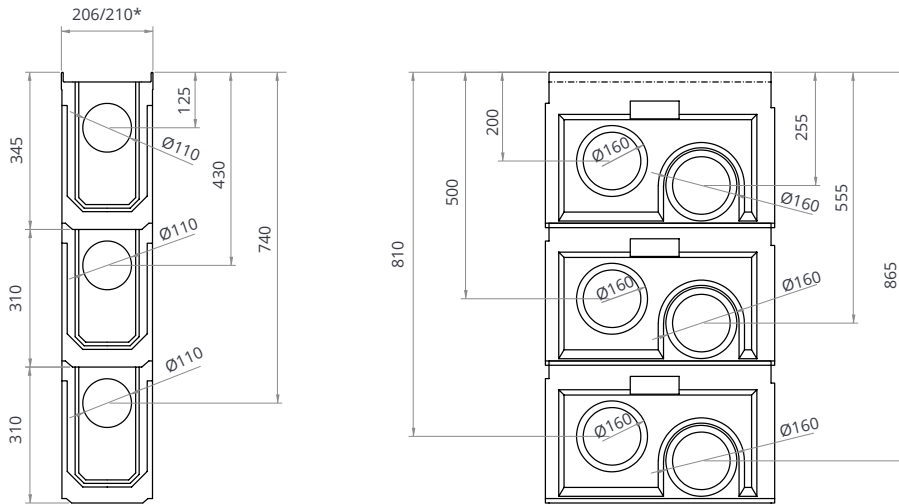

## AF150S-2 + A150I + A150B415 / AMF150-2 + A150I + A150B415\*

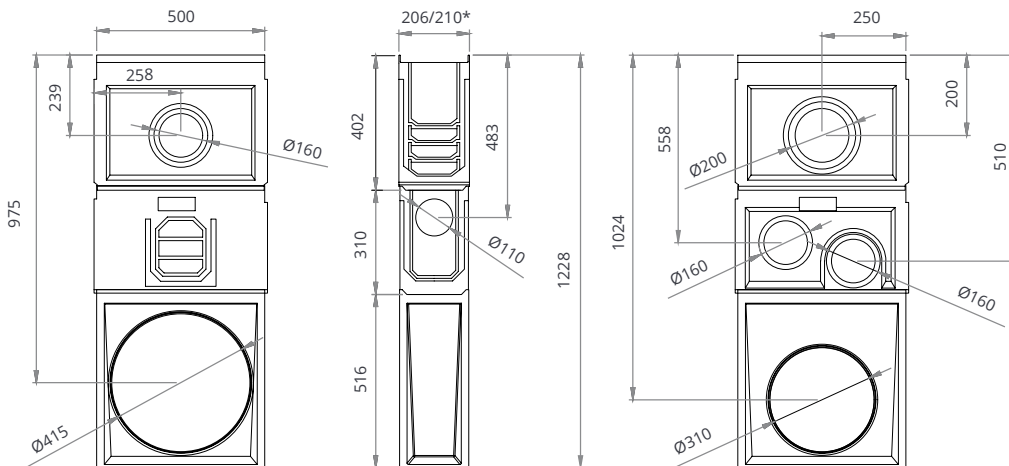

# SUMP UNITS

AF200S + A200I + A200B / AMF200S + A200I + A200B\*

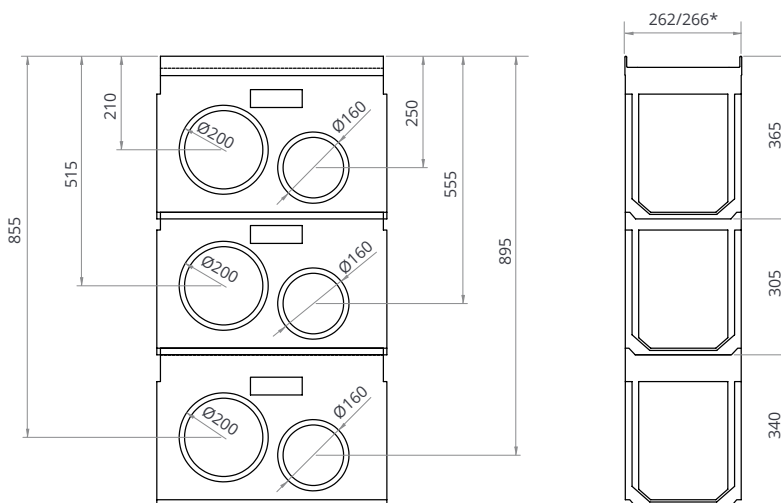

AF250S + A250I + A250B / AMF250S + A250I + A250B\*

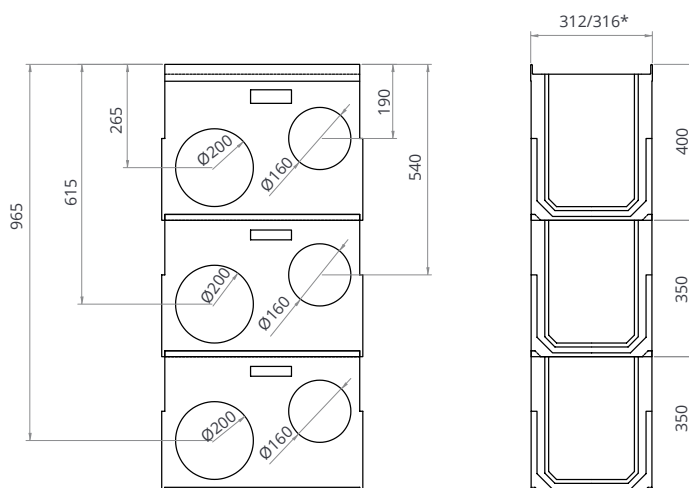

AF250-65 + A250B415 / AMF250-65 + A250B415\*

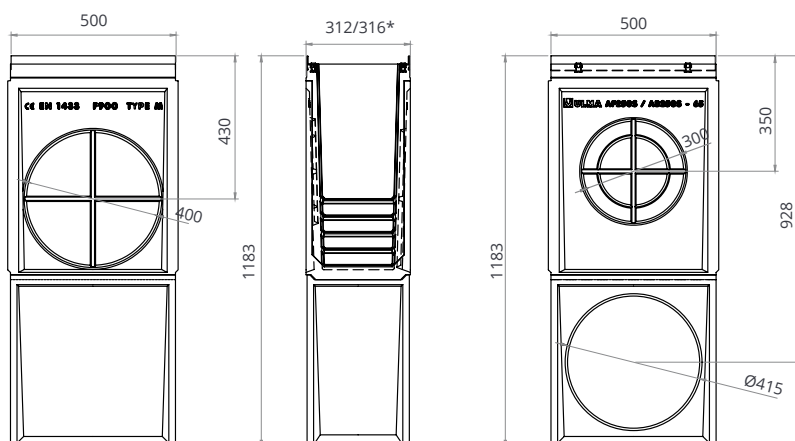

# SUMP UNITS

F250K40RS + A250B415 / F250MF40RS + A250B415\*

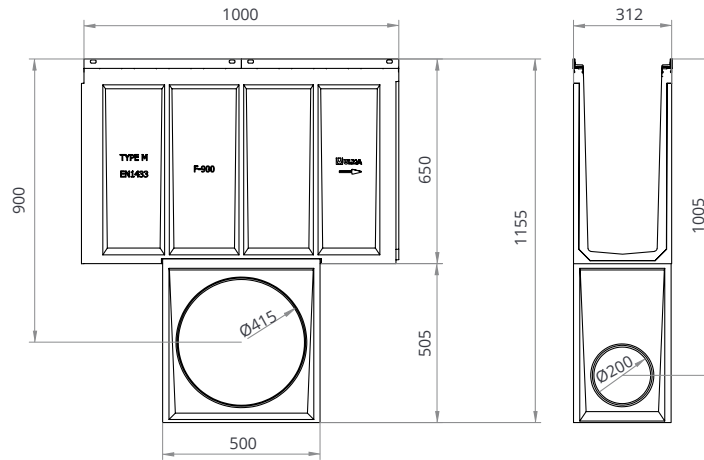

AF300+A300B / AMF300+A300B\*

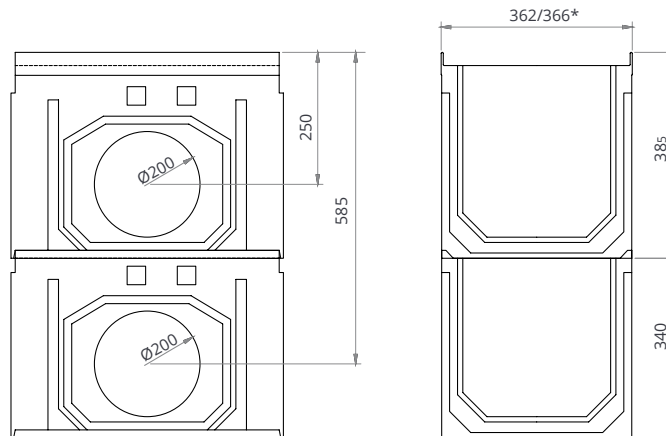

Code channel	a mm	b mm	c mm	d mm	e mm
AF300S+A300B	250	585	385	340	362

F300K60RS + UNI560 / F300MF60RS + UNI560 / F300K75RS + UNI560 / F300MF75RS + UNI560

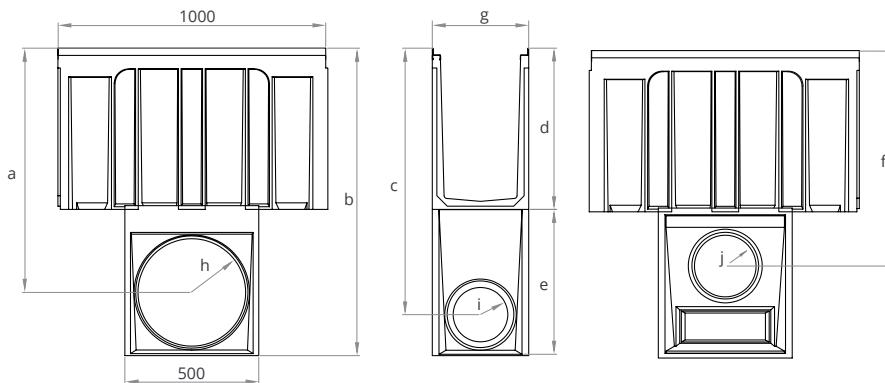

Code channel	a mm	b mm	c mm	d mm	e mm	f mm	g mm	h mm	i mm	j mm
F300K60RS+UNI560/F300MF60RS+UNI560	910	1148	995	600	540	805	362	400	200	200
F300K75RS+UNI560/F300MF75RS+UNI560	1060	1298	1145	750	540	955	362	400	200	200

# SUMP UNITS

AF400+A400B / AMF400+A400B\*

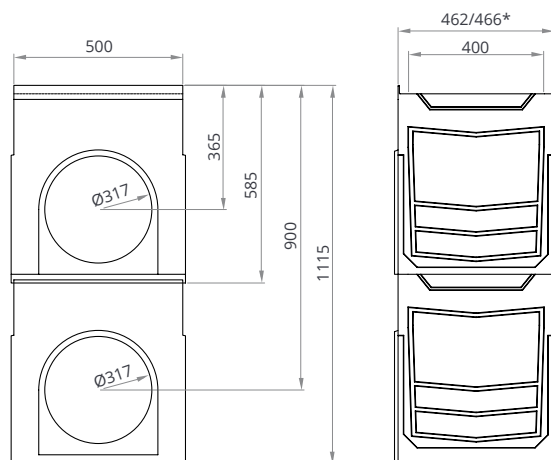

F400K40RS + A400B / F400MF40RS + A400B

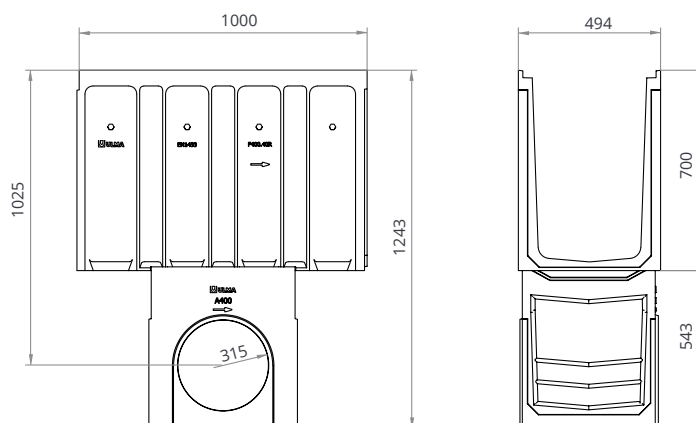

Code channel	a mm	b mm	c mm	d mm	e mm
AF400S+A400B	365	950	580	535	462

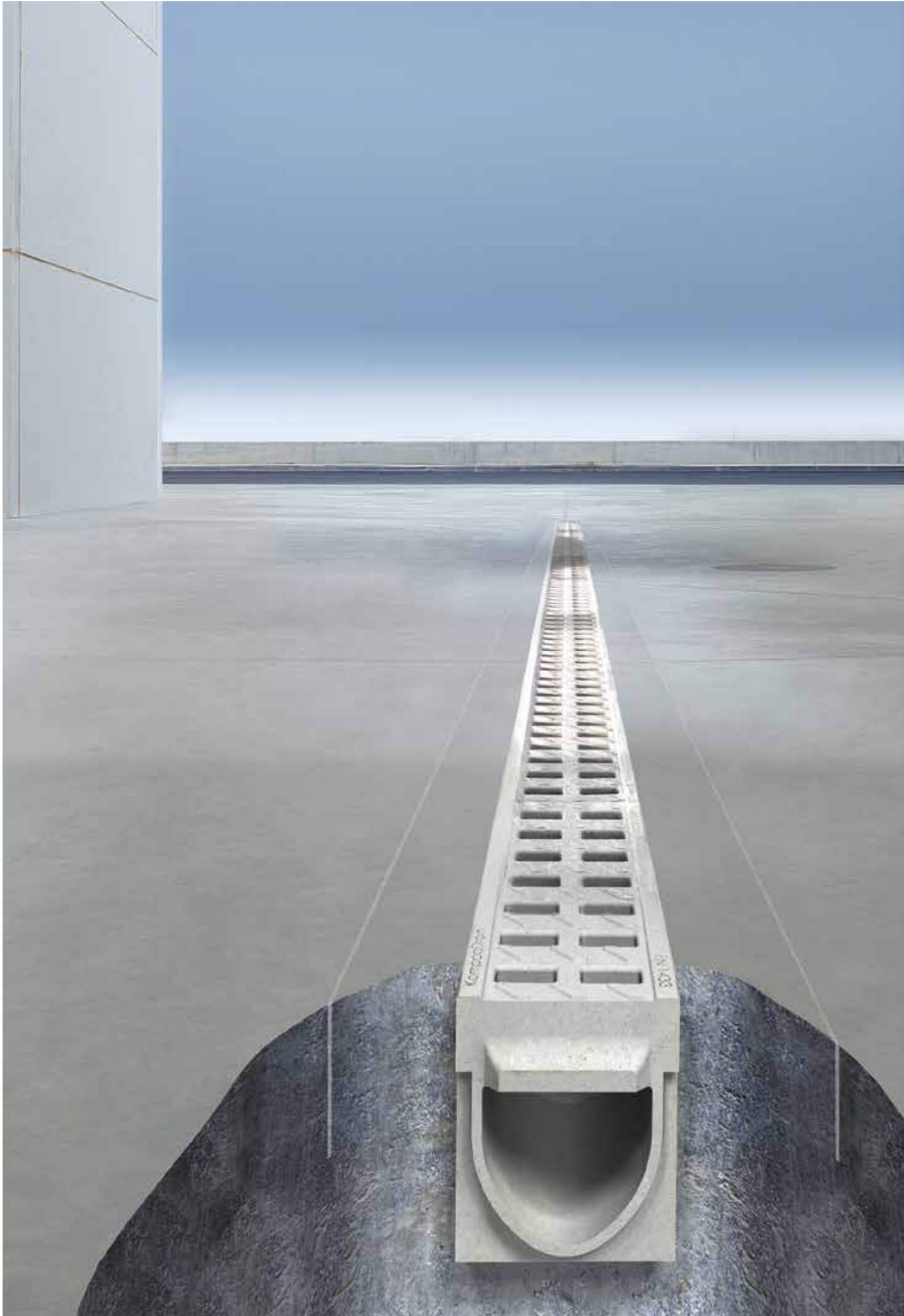

KOMPAQDRAIN®

CIVIL DRAINAGE

# KOMPAQDRAIN®

## SYSTEM

A monolithic system specially designed for areas with high traffic density by ULMA Architectural Solutions, specialists in drainage system, this novel compact channel made of polymer concrete, is suitable up to load class F900, according to standard EN-1433.

Motorways, airports, service stations and other intense traffic areas require high drainage and maximum safety, requirements to which **KOMPAQDRAIN®** responds with a combination of features that make it unique on the market.

These channels offer different surfaces according to its use.



### CITY

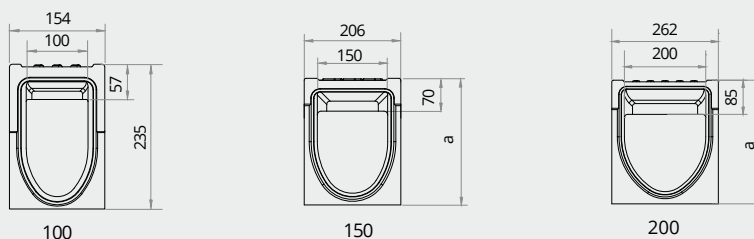

### TRAFFIC

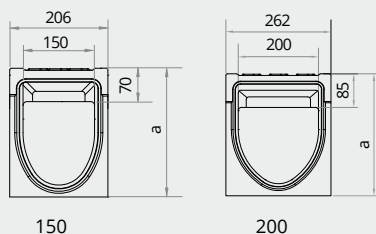

### INDUSTRY

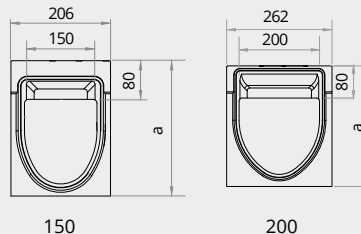

### CIVIL

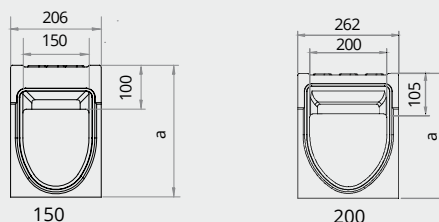



# KOMPAQDRAIN® ADVANTAGES

## Long-lasting and resistant

It is manufactured in **polymer concrete**, an anti-corrosive material, which offers great durability and exceptional resistance. Suitable to all class of loads.

## It is compact

Channel and grating form a **one-piece unit**, ensuring greater **rigidity**. Ideal for areas with maximum safety requirements.

## Directional elements

Drive water inwards, increasing intake.

## Non - slippery surface

**Special geometry** to improve the grip.

## Quick installation

Its **compactness enables an easier and faster installation**, reducing significantly the associated costs and maintenance.

## Maximum security

Motorways, airports, service stations and other intense traffic areas require **maximum safety**, requirements to which **KOMPAQDRAIN®** responds presenting the channel and grating in one piece.

## Self-cleaning

Its **"V" optimized shape** for greater hydraulic efficiency, avoid dirt blockage and ensures an efficient self-cleaning effect.

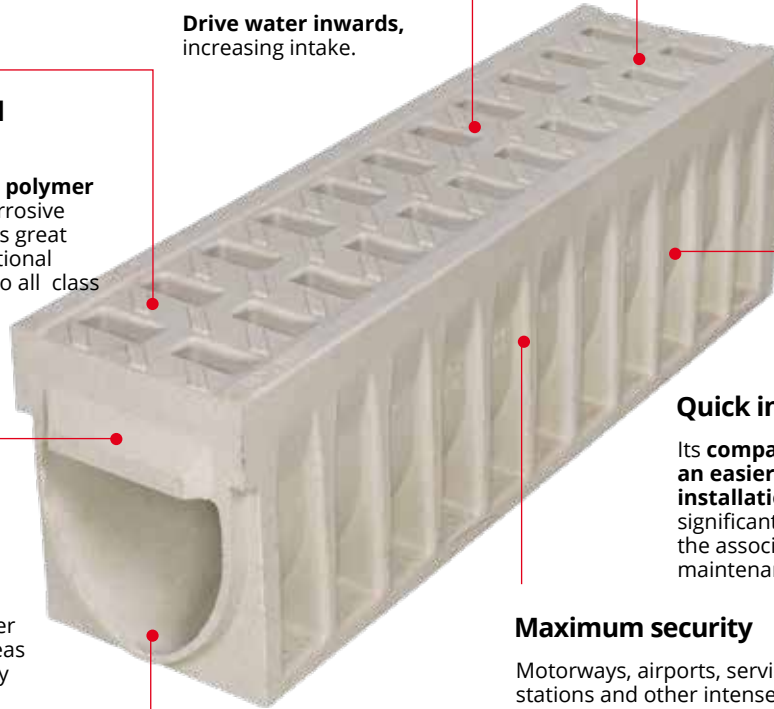

# ACCES UNIT

Stainless steel, GALVANISED steel or ductile iron edges available

Perimetral preformed groove to facilitate joint sealing in 360°

Both sides pre-marking for horizontal outlets with rapid opening geometry

Pre-marking for vertical outlet with rapid opening geometry (at register unit's bottom)

Both sides pre-markings for L, T and + connections

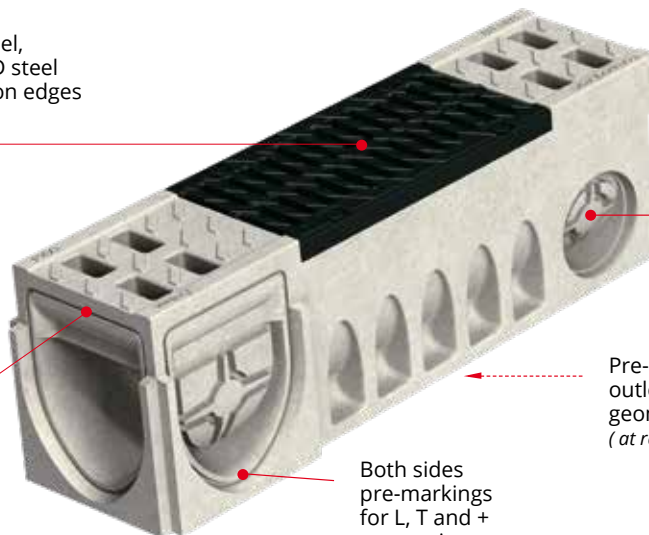

# MAX FLOW® SYSTEM

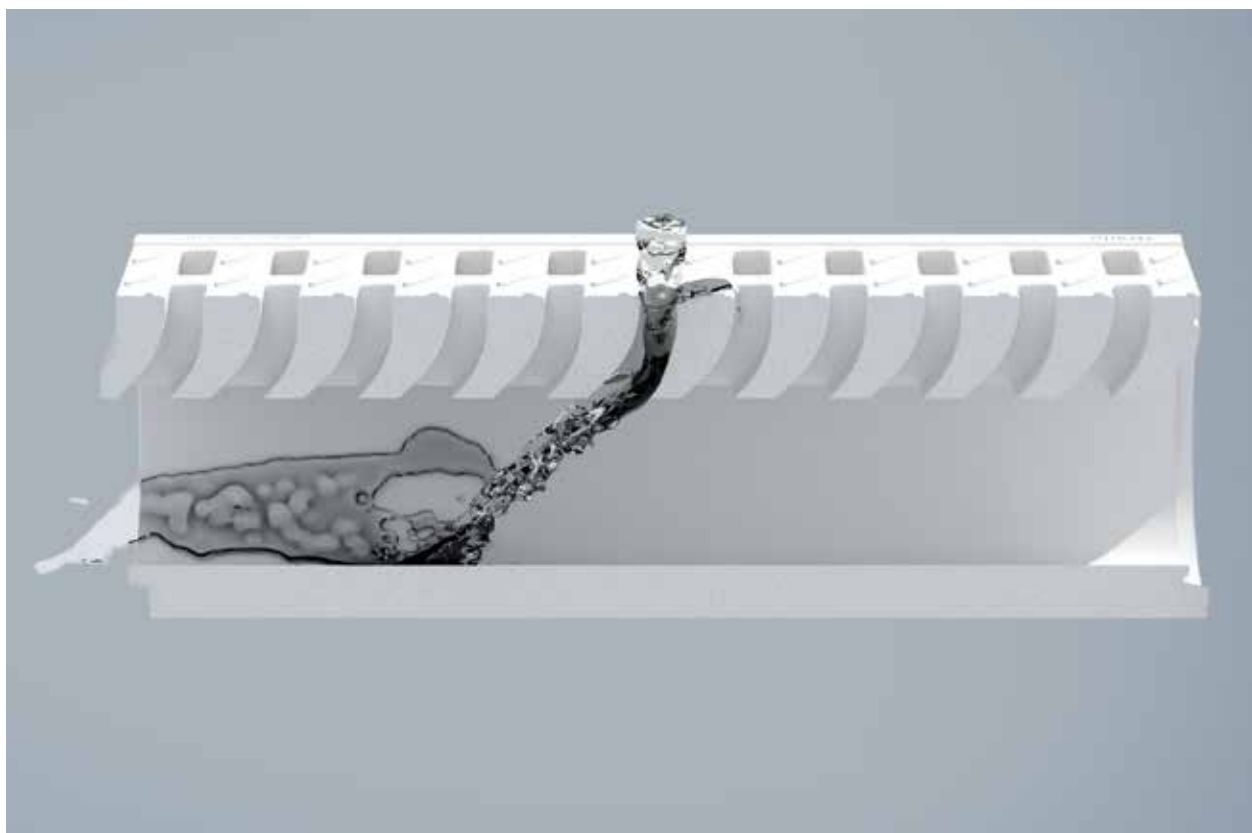

The original curved design of the inlets, together with the non-slip surface and water router, achieve the novel **Max Flow®** effect, **increasing the water speed and the drainage capacity**. Moreover, the progressive widening of the orifices helps the waste pass through more easily. Therefore **KOMPAQDRAIN®** can drain the same volume of water with a smaller channel.

**KOMPAQDRAIN®** meets all requirements of the EN-1433 international standard of quality and reliability.



CURVED DESIGN OF THE INLETS

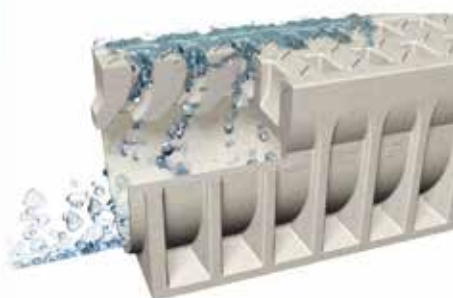

IT INCREASES THE WATER ENTRY SPEED AND THE DRAINAGE CAPACITY

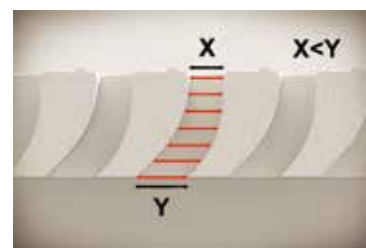

PROGRESSIVE WIDENING TO PREVENT DIRT BLOCKAGE

# KOMPAQDRAIN® OVERVIEW

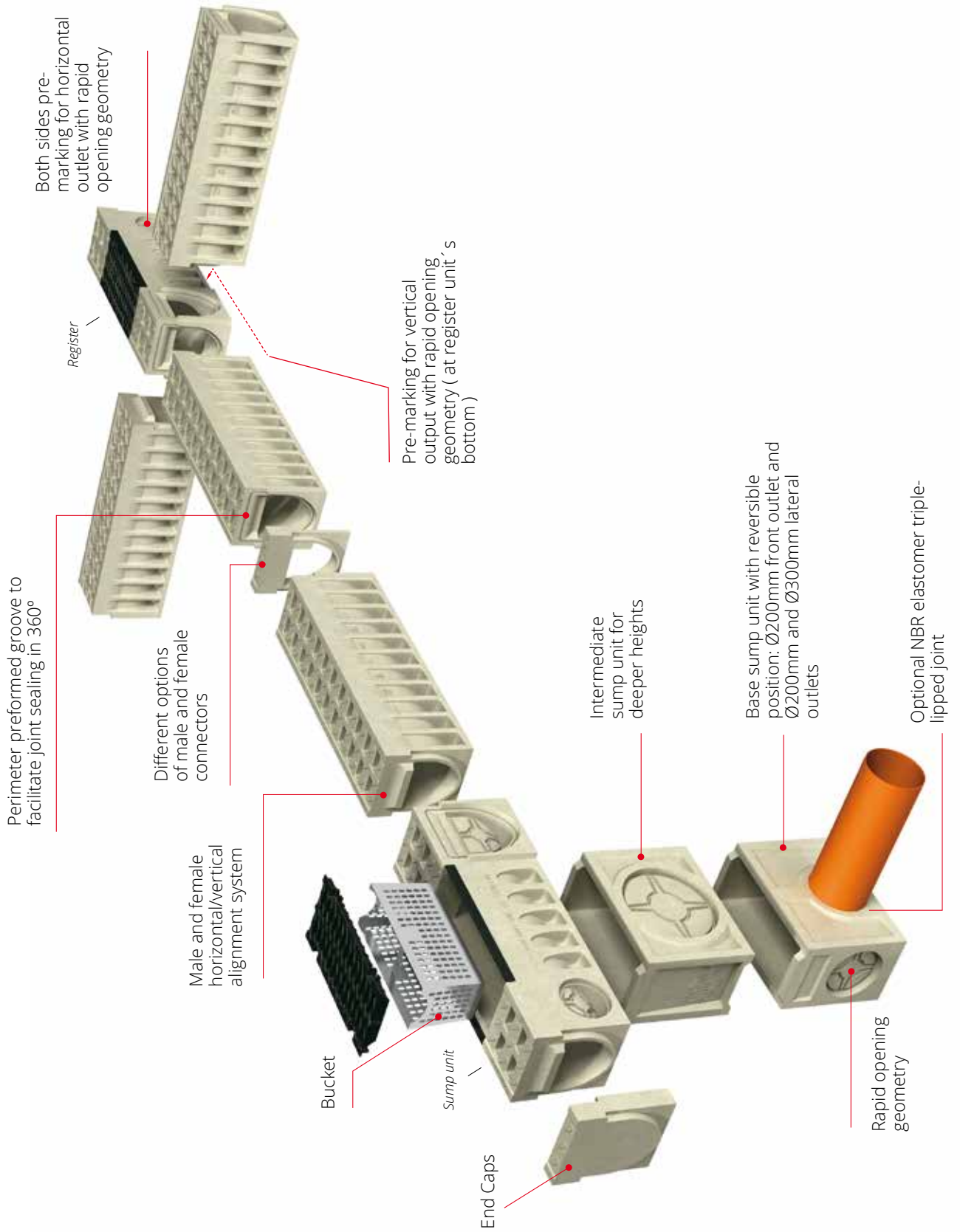

**Load Class**  
up to D400  
EN-1433 Standard

# KOMPAQ100 CITY CE

Linear Drainage Channel model **ULMA KompaqDrain® City KVDH100**, with an integral grating, presented in one-piece and manufactured by high resistant Polymer Concrete. Vandal – proof and corrosion resistant. Load class up to D-400, for all type of vehicles crossing and with reduced capture holes of 8 mm. With "V" optimized shaped and capture holes with MAX-FLOW® geometry: self-cleaning effect at a low flow, increase at maximum flow and positive opening in order to avoid dirt blockage, for areas without slope. Active surface for cutting of water sheet and for its driving to uptake holes and with non-slippery protuberances. Male and female horizontal and vertical alignment and perimeter preformed groove to facilitate joint sealing in 360°.

The access unit and the sump unit include: cast iron grating FNHX100FTDM, lateral preforms for horizontal outlets on each side and lateral preforms for connections in T, L and in cross.

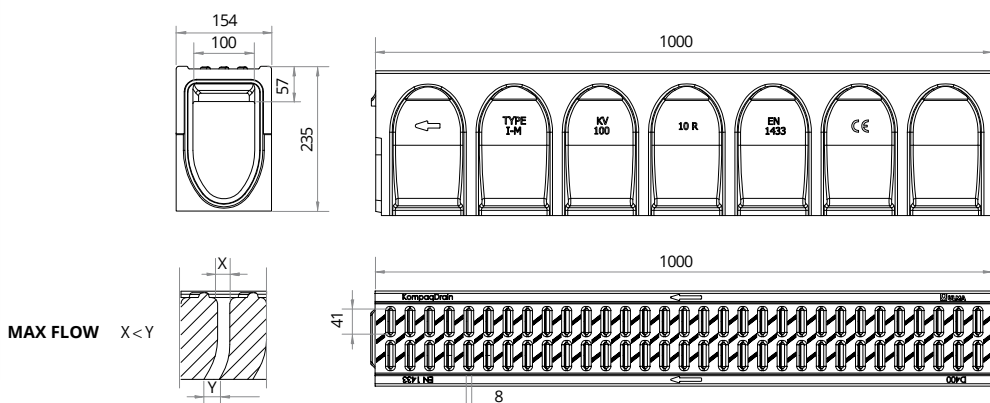

## CHANNELS

Channel code	L mm	Height mm	Channel width mm		Weight Kg	Hydraul. Section cm <sup>2</sup>	Pcs. x pallet	Intake area cm <sup>2</sup> /ml
			External	Internal				
KVDH100.10R	1000	235	154	100	32,6	139,5	28	198

## ACCESS UNITS

Channel code	L mm	Height mm	Channel width mm		Lateral Outlet mm	Vertical Outlet mm	T and + channel connection	Weight Kg	Hydraul. Section cm <sup>2</sup>	Pcs. x pallet	Intake area cm <sup>2</sup> /ml	
			Ext.	Int.								
AKVDH100MF10R	1000	235	154	100	110	110	110	Yes	40	139,5	28	159

\* Standard cast iron edges, GALVANISED and stainless steel edges available.

AKVDH100MF10R



## SUMP UNITS

Sump Unit Code	L mm	Height mm	Width mm		Frontal Outlet mm	Lateral Outlet mm	Weight Kg	Hydraul. Section cm <sup>2</sup>	Pcs. x pallet	Galva. steel bucket	Intake area cm <sup>2</sup> /ml	
			Ext.	Int.								
AKVDH100MF10RS	1000	235	154	100	-	110	110	-	139,5	28	-	159
AKVD100I	500	260	154	100	110	160	110	17	-	24	CKV100	-
AKVD100B	500	260	154	100	110	160	110	19	-	24	CKV100	-

\*\* The Sump unit can be higher incorporating an intermediate unit of 260mm. AKVD100I.

\*\*\* More info about sump units and registers on page 150

AKVDH100MF10RS



AKVD100B

## END CAPS



RC

RAJ

Channel	Code	Ø mm
KVDH100.10R	TKVDH100.10RC	-
	TKVDH100.10RAJ	90

## CONNECTORS



FFA

MMA

Channel	Code
KVDH100.10R	TCKVDH100.10RFFA
	TCKVDH100.10RMMA

## BUCKET



Code
CKV100

## SLOPE DESIGNS

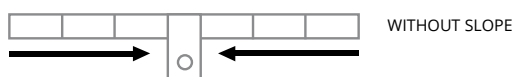

Load Class  
up to D400  
EN-1433 Standard

# KOMPAQ150

CITY CE

Linear Drainage Channel model **ULMA KompaqDrain® City KVFDH150**, with an integral grating, presented in one-piece and manufactured by high resistant Polymer Concrete. Vandal – proof and corrosion resistant. Load class up to D-400, for all type of vehicles crossing and with reduced capture holes of 13 mm. With “V” optimized shaped and capture holes with MAX-FLOW® geometry: self-cleaning effect at a low flow, increase at maximum flow and positive opening in order to avoid dirt blockage, for areas without slope. Active surface for cutting of water sheet and for its driving to uptake holes and with non-slippery protuberances. Male and female horizontal and vertical alignment and perimeter preformed groove to facilitate joint sealing in 360°.

The access unit and the sump unit include: cast iron grating FNHX150FTDM, lateral preforms for horizontal outlets on each side and lateral preforms for connections in T, L and in cross.

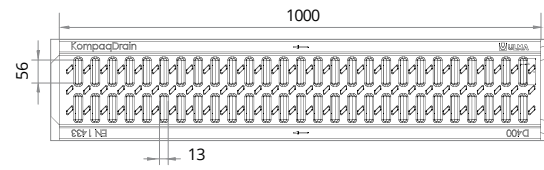
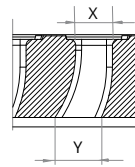
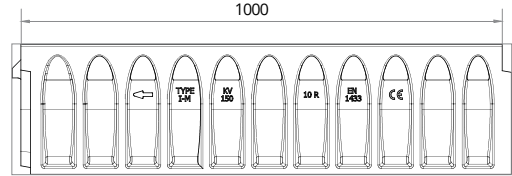
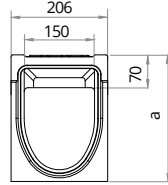

## CHANNELS

Channel code	L mm	Height mm	Channel width mm		Weight Kg	Hydraul. Section cm <sup>2</sup>	Pcs. x pallet	Intake area cm <sup>2</sup> /ml
			External	Internal				
KVFDH150.10R	1000	270	206	150	60	227	12	379
KVFDH150.20R	1000	370	206	150	70	377	12	379
KVFDH150.30R	1000	470	206	150	79	527	8	379

## ACCESS UNIT

Channel code	L mm	Height mm	Channel width mm		Lateral Outlet mm	Vertical Outlet mm	T and + channel connection	Weight Kg	Hydraul. Section cm <sup>2</sup>	Pcs. x pallet	Intake area cm <sup>2</sup> /ml
			Ext.	Int.							
AKVFDH150MF10R	1000	270	206	150	160 160	160	Yes	61	227	12	525
AKVFDH150MF20R	1000	370	206	150	200 200	160	Yes	71	377	12	525
AKVFDH150MF30R	1000	470	206	150	315 315	160	Yes	80	527	8	525

\* Standard cast iron edges, galvanised and stainless steel edges available.

AKVFDH150MF10R



## SUMP UNITS

Sump Unit Code	L mm	Height mm	Width mm		Frontal Outlet mm	Lateral Outlet mm	Weight Kg	Hydraul. Section cm <sup>2</sup>	Pcs. x pallet	Galva. steel bucket	Intake area cm <sup>2</sup> /ml
			Ext.	Int.							
AKVFDH150MF10RS	1000	270	206	150	-	160 160	58	227	12	-	525
AKVFDH150MF20RS	1000	370	206	150	-	200 200	67	377	12	-	525
AKVFDH150MF30RS	1000	470	206	150	-	315 315	76	527	8	-	525
AKVF150I	500	380	206	150	160	200 315	30	-	16	CKV150	-
AKVF150B	500	380	206	150	160	200 315	33	-	16	CKV150	-

\*\* The Sump unit can be higher incorporating an intermediate unit of 380 mm. AKVF150I

\*\*\* More info about sump units and registers on page 151

AKVFDH150MF10RS



AKVF150B

## END CAPS



RC



RAJ

## CONNECTORS



FFA



MMA

## BUCKET



CKV150

## STEP UNIT



CEKV150

Channel	Code	Ø mm
KVFDH150.10R	TKVFDH150.10RC	-
	TKVFDH150.10RAJ	110
KVFDH150.20R	TKVFDH150.20RC	-
	TKVFDH150.20RAJ	110
KVFDH150.30R	TKVFDH150.30RC	-
	TKVFDH150.30RAJ	110

Channel	Code
KVFDH150.10R	TCKVFDH150.10RFFA
	TCKVFDH150.10RMMA
KVFDH150.20R	TCKVFDH150.20RFFA
	TCKVFDH150.20RMMA
KVFDH150.30R	TCKVFDH150.30RFFA
	TCKVFDH150.30RMMA

To install in the changes of height with cascaded slope.

## SLOPE DESIGNS

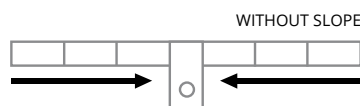

Load Class  
up to D400  
EN-1433 Standard

# KOMPAQ150 TRAFFIC CE

Linear Drainage Channel model **ULMA KompaqDrain® Traffic KVFD150**, with an integral grating, presented in one-piece and manufactured by high resistant Polymer Concrete. Vandal – proof and corrosion resistant. Load class up to D-400, for all type of vehicles crossing. With "V" optimized shaped and capture holes with MAX-FLOW® geometry: self-cleaning effect at a low flow, increase at maximum flow and positive opening in order to avoid dirt blockage, for areas without slope. Active surface for cutting of water sheet and for its driving to uptake holes and with non-slippery protuberances. Male and female horizontal and vertical alignment and perimeter preformed groove to facilitate joint sealing in 360°.

The access unit and the sump unit include: cast iron grating FN150FTDM, lateral preforms for horizontal outlets on each side and lateral preforms for connections in T, L and in cross.

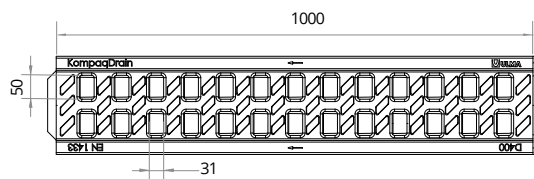
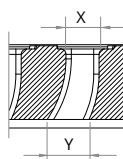
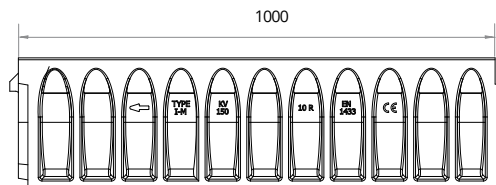
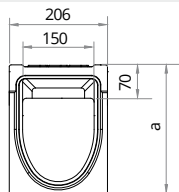

## CHANNELS

Channel code	L mm	Height mm	Channel width mm		Weigth Kg	Hydraul. Section cm²	Pcs. x pallet	Intake area cm²/ml
			External	Internal				
KVFD150.10R	1000	270	206	150	57	227	12	398
KVFD150.20R	1000	370	206	150	67	377	12	398
KVFD150.30R	1000	470	206	150	78	527	8	398

## ACCESS UNIT

Channel code	L mm	Height mm	Channel width mm		Lateral Outlet mm	Vertical Outlet mm	T and + channel connection	Weigth Kg	Hydraul. Section cm²	Pcs. x pallet	Intake area cm²/ml
			Ext.	Int.							
AKVFD150MF10R	1000	270	206	150	160 160	160	Yes	57,7	227	12	489
AKVFD150MF20R	1000	370	206	150	200 200	160	Yes	68	377	12	489
AKVFD150MF30R	1000	470	206	150	315 315	160	Yes	79	527	8	489

\* Standard cast iron edges, galvanised and stainless steel edges available.



## SUMP UNITS

Sump Unit Code	L mm	Height mm	Width mm		Frontal Outlet mm	Lateral Outlet mm	Weigth Kg	Hydraul. Section cm²	Pcs. x pallet	Galva. steel bucket	Intake area cm²/ml
			Ext.	Int.							
AKVFD150MF10RS	1000	270	206	150	-	160 160	54	227	12	-	489
AKVFD150MF20RS	1000	370	206	150	-	200 200	64	377	12	-	489
AKVFD150MF30RS	1000	470	206	150	-	315 315	75	527	8	-	489
AKVF150I	500	380	206	150	160	200 315	30	-	16	CKV150	-
AKVF150B	500	380	206	150	160	200 315	33	-	16	CKV150	-

\*\* The Sump unit can be higher incorporating an intermediate unit of 380 mm. AKVF150I  
 \*\*\* More info about sump units and registers on page 151



## END CAPS



RC



RAJ



FFA



MMA

Channel	Code	Ø mm
KVFD150.10R	TKVFD150.10RC	-
	TKVFD150.10RAJ	110
KVFD150.20R	TKVFD150.20RC	-
	TKVFD150.20RAJ	110
KVFD150.30R	TKVFD150.30RC	-
	TKVFD150.30RAJ	110

## CONNECTORS



Channel	Code
KVFD150.10R	TCKVFD150.10RFFA
	TCKVFD150.10RMMA
KVFD150.20R	TCKVFD150.20RFFA
	TCKVFD150.20RMMA
KVFD150.30R	TCKVFD150.30RFFA
	TCKVFD150.30RMMA

## BUCKET



Code
CKV150

## STEP UNIT



Code
CEKV150

To install in the changes of height with cascaded slope.

## SLOPE DESIGNS



Load Class  
up to E600  
EN-1433 Standard

# KOMPAQ150 INDUSTRY CE

Linear Drainage Channel model **ULMA KompaqDrain® Industry KVE150**, with an integral grating, presented in one-piece and manufactured by high resistant Polymer Concrete. Vandal – proof and corrosion resistant. Load class up to E-600 with surface design without protuberances to avoid vibrations in crossing vehicles, 30 x 25 mm uptake holes. With "V" optimized shaped and capture holes with MAX-FLOW® geometry: self-cleaning effect at a low flow, increase at maximum flow and positive opening in order to avoid dirt blockage, for areas without slope. Active surface for cutting of water sheet and for its driving to uptake holes. Male and female horizontal and vertical alignment and perimeter preformed groove to facilitate joint sealing in 360°.

The access unit and the sump unit include: cast iron grating FN150FTEM, lateral preforms for horizontal outlets on each side and lateral preforms for connections in T, L and in cross.

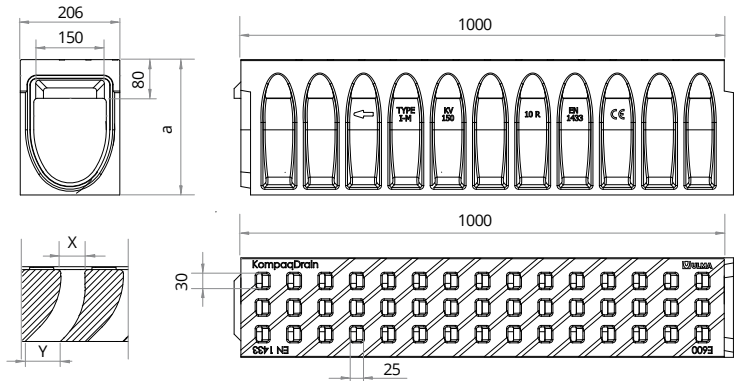
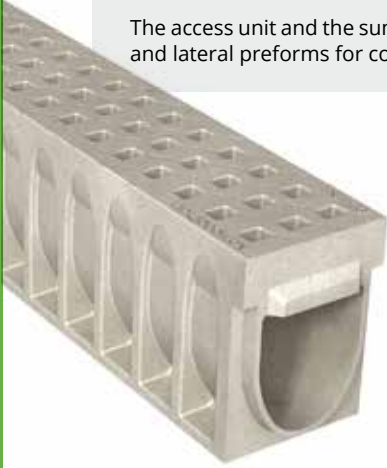

## CHANNELS

Channel code	L mm	Height mm	Channel width mm		Weight Kg	Hydraul. Section cm <sup>2</sup>	Pcs. x pallet	Intake area cm <sup>2</sup> /ml
			External	Internal				
KVE150.10R	1000	280	206	150	59	227	12	360
KVE150.20R	1000	380	206	150	69	377	12	360
KVE150.30R	1000	480	206	150	80	527	8	360

## ACCESS UNIT

Channel code	L mm	Height mm	Channel width mm		Lateral Outlet mm	Vertical Outlet mm	T and + channel connection	Weight Kg	Hydraul. Section cm <sup>2</sup>	Pcs. x pallet	Intake area cm <sup>2</sup> /ml
			Ext.	Int.							
AKVE150MF10R	1000	280	206	150	160 160	160	Yes	59	227	12	529
AKVE150MF20R	1000	380	206	150	200 200	160	Yes	70	377	12	529
AKVE150MF30R	1000	480	206	150	315 315	160	Yes	80	527	8	529

\* Standard cast iron edges, galvanised and stainless steel edges available.



## SUMP UNITS

Sump Unit Code	L mm	Height mm	Width mm		Frontal Outlet mm	Lateral Outlet mm	Weight Kg	Hydraul. Section cm <sup>2</sup>	Pcs. x pallet	Galva. steel bucket	Intake area cm <sup>2</sup> /ml
			Ext.	Int.							
AKVE150MF10RS	1000	280	206	150	-	160 160	56	227	12	-	529
AKVE150MF20RS	1000	380	206	150	-	200 200	67	377	12	-	529
AKVE150MF30RS	1000	480	206	150	-	315 315	77	527	8	-	529
AKVF150I	500	380	206	150	160	200 315	30	-	16	CKV150	-
AKVF150B	500	380	206	150	160	200 315	33	-	16	CKV150	-

\*\* The Sump unit can be higher incorporating an intermediate unit of 380 mm. AKVF150I

\*\*\* More info about sump units and registers on page 151



## END CAPS



Channel	Code	Ø mm
KVE150.10R	TKVE150.10RC	-
	TKVE150.10RAJ	110
KVE150.20R	TKVE150.20RC	-
	TKVE150.20RAJ	110
KVE150.30R	TKVE150.30RC	-
	TKVE150.30RAJ	110

## CONNECTORS

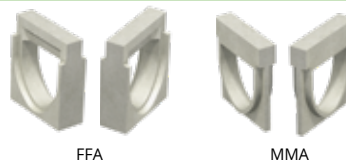

Channel	Code
KVE150.10R	TCKVE150.10RFFA
	TCKVE150.10RMMA
KVE150.20R	TCKVE150.20RFFA
	TCKVE150.20RMMA
KVE150.30R	TCKVE150.30RFFA
	TCKVE150.30RMMA

## BUCKET



Code
CKV150

## STEP UNIT



Code
CEKV150

To install in the changes of height with cascaded slope.

## SLOPE DESIGNS



Load Class  
up to F900  
EN-1433 Standard

# KOMPAQ150

CIVIL



Linear Drainage Channel model **ULMA KompaqDrain® Civil KVF150**, with an integral grating, presented in one-piece and manufactured by high resistant Polymer Concrete. Vandal - proof and corrosion resistant. Load class up to F-900, for heavy loads. With "V" optimized shaped and capture holes with MAX-FLOW® geometry: self-cleaning effect at a low flow, increase at maximum flow and positive opening in order to avoid dirt blockage, for areas without slope. Active surface for cutting of water sheet and for its driving to uptake holes and with non-slippery protuberances. Male and female horizontal and vertical alignment and perimeter preformed groove to facilitate joint sealing in 360°.

The access unit and the sump unit include: cast iron grating FN150FTFM, lateral preforms for horizontal outlets on each side and lateral preforms for connections in T, L and in cross.

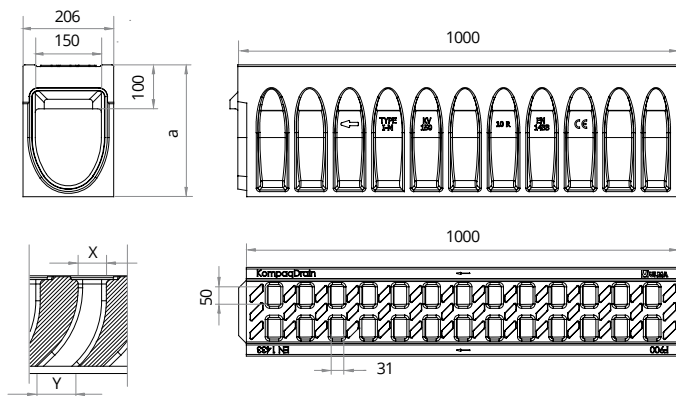

## CHANNELS

Channel code	L mm	Height mm	Channel width mm		Weight Kg	Hydraul. Section cm <sup>2</sup>	Pcs. x pallet	Intake area cm <sup>2</sup> /ml
			External	Internal				
KVF150.10R	1000	300	206	150	65	227	12	398
KVF150.20R	1000	400	206	150	75	377	12	398
KVF150.30R	1000	500	206	150	84	527	8	398

## ACCESS UNIT

Channel code	L mm	Height mm	Channel width mm		Lateral Outlet mm	Vertical Outlet mm	T and + channel connection	Weight Kg	Hydraul. Section cm <sup>2</sup>	Pcs. x pallet	Intake area cm <sup>2</sup> /ml
			Ext.	Int.							
AKVF150MF10R	1000	300	206	150	160	160	Yes	69	227	12	514
AKVF150MF20R	1000	400	206	150	200	200	Yes	79	377	12	514
AKVF150MF30R	1000	500	206	150	315	315	Yes	89	527	8	514

\* Standard cast iron edges, galvanised and stainless steel edges available.

AKVF150MF10R



## SUMP UNITS

Sump Unit Code	L mm	Height mm	Width mm		Frontal Outlet mm	Lateral Outlet mm	Weight Kg	Hydraul. Section cm <sup>2</sup>	Pcs. x pallet	Galva. steel bucket	Intake area cm <sup>2</sup> /ml	
			Ext.	Int.								
AKVF150MF10RS	1000	300	206	150	-	160	160	66	227	12	-	514
AKVF150MF20RS	1000	400	206	150	-	200	200	76	377	12	-	514
AKVF150MF30RS	1000	500	206	150	-	315	315	86	527	8	-	514
AKVF150I	500	380	206	150	160	200	315	30	-	16	CKV150	-
AKVF150B	500	380	206	150	160	200	315	33	-	16	CKV150	-

\*\* The Sump unit can be higher incorporating an intermediate unit of 380 mm. AKVF150I

\*\*\* More info about sump units and registers on page 151

AKVF150MF10RS



AKVF150B



## END CAPS



RC



RAJ

## CONNECTORS



FFA



MMA

## BUCKET



CKV150

## STEP UNIT



CEKV150

Channel	Code	Ø mm
KVF150.10R	TKVF150.10RC	-
	TKVF150.10RAJ	110
KVF150.20R	TKVF150.20RC	-
	TKVF150.20RAJ	110
KVF150.30R	TKVF150.30RC	-
	TKVF150.30RAJ	110

Channel	Code
KVF150.10R	TCKVF150.10RFFA
	TCKVF150.10RMMA
KVF150.20R	TCKVF150.20RFFA
	TCKVF150.20RMMA
KVF150.30R	TCKVF150.30RFFA
	TCKVF150.30RMMA

To install in the changes of height with cascaded slope.

## SLOPE DESIGNS

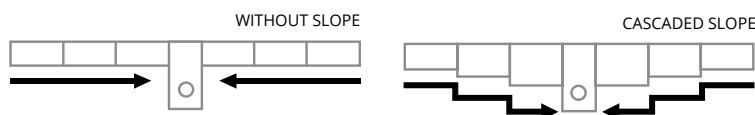



Load Class  
up to D400  
EN-1433 Standard

# KOMPAQ200 CITY CE

Linear Drainage Channel model **ULMA KompaqDrain® City KVFDH200** with an integral grating, presented in one-piece and manufactured by high resistant Polymer Concrete. Vandal – proof and corrosion resistant. Load class up to D-400, for all type of vehicles crossing and with reduced capture holes of 16mm. With “V” optimized shaped and capture holes with MAX-FLOW® geometry: self-cleaning effect at a low flow, increase at maximum flow and positive opening in order to avoid dirt blockage, for areas without slope. Active surface for cutting of water sheet and for its driving to uptake holes and with non-slippery protuberances. Male and female horizontal and vertical alignment and perimeter preformed groove to facilitate joint sealing in 360°.

The access unit and the sump unit include: cast iron grating FNX200FTDM, lateral preforms for horizontal outlets on each side and lateral preforms for connections in T, L and in cross.

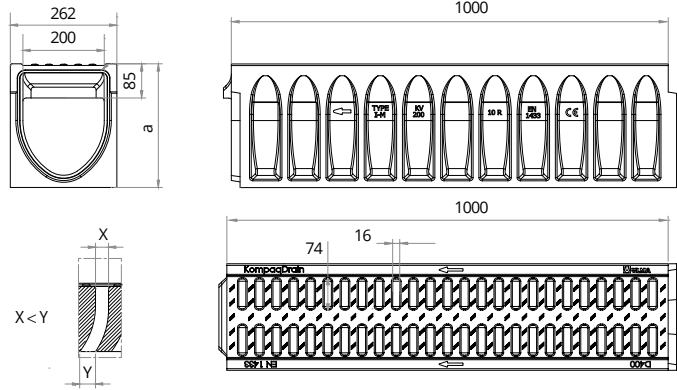

MAX FLOW X < Y

## CHANNELS

Channel code	L mm	Height mm	Channel width mm		Weight Kg	Hydraul. Section cm²	Pcs. x pallet	Intake area cm²/ml
			External	Internal				
KVFDH200.10R	1000	305	262	200	79	318	12	573
KVFDH200.30R	1000	505	262	200	101	718	8	573
KVFDH200.50R	1000	705	262	200	131	1118	8	573

## ACCESS UNIT

Channel code	L mm	Height mm	Channel width mm		Lateral Outlet mm	Vertical Outlet mm	T and + channel connection	Weight Kg	Hydraul. Section cm²	Pcs. x pallet	Intake area cm²/ml
			Ext.	Int.							
AKVFDH200MF10R	1000	305	262	200	160 160	160	Yes	81	318	12	528
AKVFDH200MF30R	1000	505	262	200	315 315	200	Yes	105	718	8	528
AKVFDH200MF50R	1000	705	262	200	400 400	200	Yes	135	1118	8	528

\* Standard cast iron edges, galvanised and stainless steel edges available.

AKVFDH200MF10R



## SUMP UNITS

Sump Unit Code	L mm	Height mm	Width mm		Frontal Outlet mm	Lateral Outlet mm	Weight Kg	Hydraul. Section cm²	Pcs. x pallet	Galva. steel bucket	Intake area cm²/ml
			Ext.	Int.							
AKVFDH200MF10RS	1000	305	262	200	-	160 160	75	318	12	-	528
AKVFDH200MF30RS	1000	505	262	200	-	315 315	99	718	8	-	528
AKVFDH200MF50RS	1000	705	262	200	-	400 400	129	1118	8	-	528
AKVF200I	500	380	262	200	200	200 315	34	-	16	CKV200	-
AKVF200B	500	380	262	200	200	200 315	38	-	16	CKV200	-

\*\* The Sump unit can be higher incorporating an intermediate unit of 380 mm. AKVF200I.

\*\*\* More info about sump units and registers on page 152

AKVFDH200MF10RS



AKVF200B

## END CAPS



RC

RAJ

Channel	Code	Ø mm
KVFDH200.10R	TKVFDH200.10RC	-
	TKVFDH200.10RAJ	160
KVFDH200.30R	TKVFDH200.30RC	-
	TKVFDH200.30RAJ	200
KVFDH200.50R	TKVFDH200.50RC	-

## CONNECTORS



FFA

MMA

Channel	Code
KVFDH200.10R	TCKVFDH200.10RFFA
	TCKVFDH200.10RMMA
KVFDH200.30R	TCKVFDH200.30RFFA
	TCKVFDH200.30RMMA
KVFDH200.50R	TCKVFDH200.50RFFA
	TCKVFDH200.50RMMA

## BUCKET



Code  
CKV200

## STEP UNIT



Code  
CEKV200

To install in the changes of height with cascaded slope.

## SLOPE DESIGNS



**Load Class**  
up to **D400**  
EN-1433 Standard

# KOMPAQ200 TRAFFIC CE

Linear Drainage Channel model **ULMA KompaqDrain® Traffic KVFD200**, with an integral grating, presented in one-piece and manufactured by high resistant Polymer Concrete. Vandal – proof and corrosion resistant. Load class up to D-400, for all type of vehicles crossing. With “V” optimized shaped and capture holes with **MAX-FLOW®** geometry: self-cleaning effect at a low flow, increase at maximum flow and positive opening in order to avoid dirt blockage, for areas without slope. Active surface for cutting of water sheet and for its driving to uptake holes and with non-slippery protuberances. Male and female horizontal and vertical alignment and perimeter preformed groove to facilitate joint sealing in 360°.

The access unit and the sump unit include: cast iron grating **FNX200FTDM**, lateral preforms for horizontal outlets on each side and lateral preforms for connections in T, L and in cross.

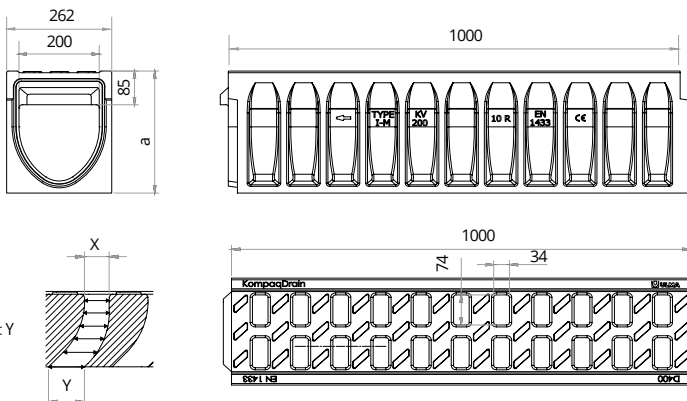

## CHANNELS

Channel code	L mm	Height mm	Channel width mm		Weight Kg	Hydraul. Section cm <sup>2</sup>	Pcs. x pallet	Intake area cm <sup>2</sup> /ml
			External	Internal				
KVFD200.10R	1000	305	262	200	78	318	12	577
KVFD200.30R	1000	505	262	200	101	718	8	577
KVFD200.50R	1000	705	262	200	131	1118	8	577

## ACCESS UNIT

Channel code	L mm	Height mm	Channel width mm		Lateral Outlet mm	Vertical Outlet mm	T and + channel connection	Weight Kg	Hydraul. Section cm <sup>2</sup>	Pcs. x pallet	Intake area cm <sup>2</sup> /ml
			Ext.	Int.							
AKVFD200MF10R	1000	305	262	200	160 160	160	Yes	80	318	12	486
AKVFD200MF30R	1000	505	262	200	315 315	200	Yes	104	718	8	486
AKVFD200MF50R	1000	705	262	200	400 400	200	Yes	135	1118	8	486

\* Standard cast iron edges, galvanised and stainless steel edges available.



## SUMP UNITS

Sump Unit Code	L mm	Height mm	Width mm		Frontal Outlet mm	Lateral Outlet mm	Weight Kg	Hydraul. Section cm <sup>2</sup>	Pcs. x pallet	Galva. steel bucket	Intake area cm <sup>2</sup> /ml
			Ext.	Int.							
AKVFD200MF10RS	1000	305	262	200	-	160 160	74	318	12	-	486
AKVFD200MF30RS	1000	505	262	200	-	315 315	98	718	8	-	486
AKVFD200MF50RS	1000	705	262	200	-	400 400	128	1118	8	-	486
AKVF200I	500	380	262	200	200	200 315	34	-	16	CKV200	-
AKVF200B	500	380	262	200	200	200 315	38	-	16	CKV200	-

\*\* The Sump unit can be higher incorporating an intermediate unit of 380 mm. AKVF200I.

\*\*\* More info about sump units and registers on page 152



## END CAPS



Channel	Code	Ø mm
KVFD200.10R	TKVFD200.10RC	-
	TKVFD200.10RAJ	160
KVFD200.30R	TKVFD200.30RC	-
	TKVFD200.30RAJ	200
KVFD200.50R	TKVFD200.50RC	-

## CONNECTORS



Channel	Code
KVFD200.10R	TCKVFD200.10RFFA
	TCKVFD200.10RMMA
KVFD200.30R	TCKVFD200.30RFFA
	TCKVFD200.30RMMA
KVFD200.50R	TCKVFD200.50RFFA
	TCKVFD200.50RMMA

## BUCKET



Code
CKV200

## STEP UNIT



Code
CEKV200

To install in the changes of height with cascaded slope.

## SLOPE DESIGNS



Load Class  
up to E600  
EN-1433 Standard

# KOMPAQ200 INDUSTRY CE

Linear Drainage Channel model **ULMA KompaqDrain® Industry KVE200**, with an integral grating, presented in one-piece and manufactured by high resistant Polymer Concrete. Vandal – proof and corrosion resistant. Load class up to E-600 with surface design without protuberances to avoid vibrations in crossing vehicles, 30 x 25 mm uptake holes. With “V” optimized shaped and capture holes with MAX-FLOW® geometry: self-cleaning effect at a low flow, increase at maximum flow and positive opening in order to avoid dirt blockage, for areas without slope. Active surface for cutting of water sheet and for its driving to uptake holes. Male and female horizontal and vertical alignment and perimeter preformed groove to facilitate joint sealing in 360°.

The access unit and the sump unit include: cast iron grating FNX200FTEM, lateral preforms for horizontal outlets on each side and lateral preforms for connections in T, L and in cross.

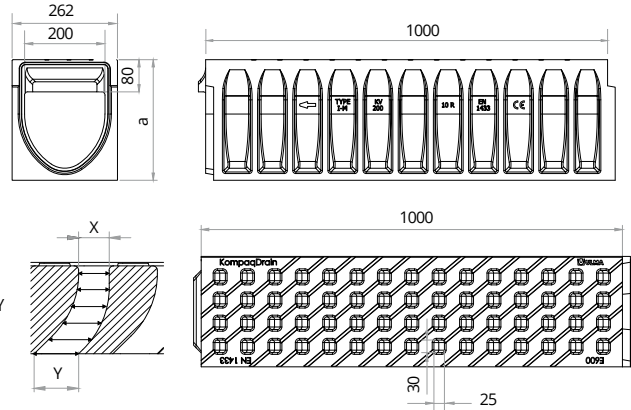
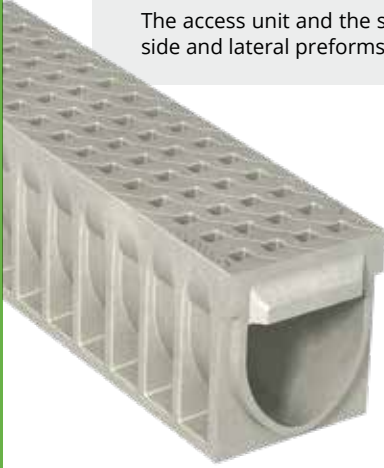

## CHANNELS

Channel code	L mm	Height mm	Channel width mm		Weigth Kg	Hydraul. Section cm²	Pcs. x pallet	Intake area cm²/ml
			External	Internal				
KVE200.10R	1000	300	262	200	81	318	12	480
KVE200.30R	1000	500	262	200	104	718	8	480
KVE200.50R	1000	700	262	200	134	1118	8	480

## ACCESS UNIT

Channel code	L mm	Height mm	Channel width mm		Lateral Outlet mm	Vertical Outlet mm	T and + channel connection	Weigth Kg	Hydraul. Section cm²	Pcs. x pallet	Intake area cm²/ml
			Ext.	Int.							
AKVE200MF10R	1000	300	262	200	160 160	160	Yes	82	318	12	500
AKVE200MF30R	1000	500	262	200	315 315	200	Yes	106	718	8	500
AKVE200MF50R	1000	700	262	200	400 400	200	Yes	137	1118	8	500

\* Standard cast iron edges, galvanised and stainless steel edges available.

AKVE200MF10R



## SUMP UNITS

Sump Unit Code	L mm	Height mm	Width mm		Frontal Outlet mm	Lateral Outlet mm	Weigth Kg	Hydraul. Section cm²	Pcs. x pallet	Galva. steel bucket	Intake area cm²/ml
			Ext.	Int.							
AKVE200MF10RS	1000	300	262	200	-	160 160	76	318	12	-	500
AKVE200MF30RS	1000	500	262	200	-	315 315	100	718	8	-	500
AKVE200MF50RS	1000	700	262	200	-	400 400	130	1118	8	-	500
AKVF200I	500	380	262	200	200	200 315	34	-	16	CKV200	-
AKVF200B	500	380	262	200	200	200 315	38	-	16	CKV200	-

\*\* The Sump unit can be higher incorporating an intermediate unit of 380 mm. AKVF200I.

\*\*\* More info about sump units and registers on page 152

AKVE200MF10RS



AKVF200B

## END CAPS



Channel	Code	Ø mm
KVE200.10R	TKVE200.10RC	-
	TKVE200.10RAJ	160
KVE200.30R	TKVE200.30RC	-
	TKVE200.30RAJ	200
KVE200.50R	TKVE200.50RC	-

## CONNECTORS

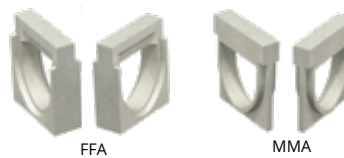

Channel	Code
KVE200.10R	TCKVE200.10RFFA
	TCKVE200.10RMMA
KVE200.30R	TCKVE200.30RFFA
	TCKVE200.30RMMA
KVE200.50R	TCKVE200.50RFFA
	TCKVE200.50RMMA

## BUCKET



Code
CKV200

## STEP UNIT



Code
CEKV200

To install in the changes of height with cascaded slope.

## SLOPE DESIGNS



**Load Class  
up to F900**  
EN-1433 Standard

# KOMPAQ200

**CIVIL**



Linear Drainage Channel model **ULMA KompaqDrain® Civil KVF200**, with an integral grating, presented in one-piece and manufactured by high resistant Polymer Concrete. Vandal – proof and corrosion resistant. Load class up to F-900 for high loads. With “V” optimized shaped and capture holes with MAX-FLOW® geometry: self-cleaning effect at a low flow, increase at maximum flow and positive opening in order to avoid dirt blockage, for areas without slope. Active surface for cutting of water sheet and for its driving to uptake holes and with non-slippery protuberances. Male and female horizontal and vertical alignment and perimeter preformed groove to facilitate joint sealing in 360°.

The access unit and the sump unit include cast iron grating FNX200FTFM, lateral preforms for horizontal outlets on each side and lateral preforms for connections in T, L and in cross.

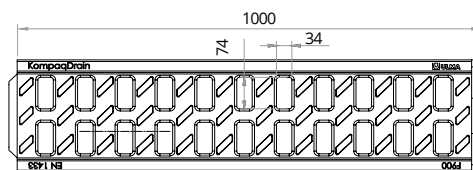
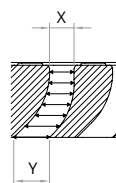
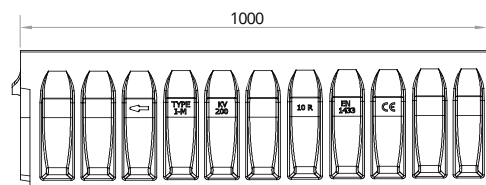
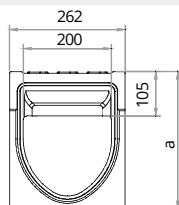

## CHANNELS

Channel code	L mm	Height mm	Channel width mm		Weight Kg	Hydraul. Section cm <sup>2</sup>	Pcs. x pallet	Intake area cm <sup>2</sup> /ml
			External	Internal				
KVF200.10R	1000	325	262	200	88	318	12	577
KVF200.30R	1000	525	262	200	111	718	8	577
KVF200.50R	1000	725	262	200	141	1118	8	577

## ACCESS UNIT

Channel code	L mm	Height mm	Channel width mm		Lateral Outlet mm	Vertical Outlet mm	T and + channel connection	Weight Kg	Hydraul. Section cm <sup>2</sup>	Pcs. x pallet	Intake area cm <sup>2</sup> /ml	
			Ext.	Int.								
AKVF200MF10R	1000	325	262	200	160	160	160	Yes	90	318	12	670
AKVF200MF30R	1000	525	262	200	315	315	200	Yes	115	718	8	670
AKVF200MF50R	1000	725	262	200	400	400	200	Yes	145	1118	8	670

\* Standard cast iron edges, galvanised and stainless steel edges available.

AKVF200MF10R



## SUMP UNITS

Sump Unit Code	L mm	Height mm	Width mm		Frontal Outlet mm	Lateral Outlet mm	Weight Kg	Hydraul. Section cm <sup>2</sup>	Pcs. x pallet	Galva. steel bucket	Intake area cm <sup>2</sup> /ml	
			Ext.	Int.								
AKVF200MF10RS	1000	325	262	200	-	160	160	84	318	12	-	670
AKVF200MF30RS	1000	525	262	200	-	315	315	108	718	8	-	670
AKVF200MF50RS	1000	725	262	200	-	400	400	138	1118	8	-	670
AKVF200I	500	380	262	200	200	200	315	34	-	16	CKV200	-
AKVF200B	500	380	262	200	200	200	315	38	-	16	CKV200	-

\*\* The Sump unit can be higher incorporating an intermediate unit of 380 mm. AKVF200I.

\*\*\* More info about sump units and registers on page 152

AKVF200MF10RS



AKVF200B

## END CAPS



RC



RAJ

Channel	Code	Ø mm
KVF200.10R	TKVF200.10RC	-
	TKVF200.10RAJ	160
KVF200.30R	TKVF200.30RC	-
	TKVF200.30RAJ	200
KVF200.50R	TKVF200.50RC	-

## CONNECTORS



FFA



MMA

Channel	Code
KVF200.10R	TCKVF200.10RFFA
	TCKVF200.10RMMA
KVF200.30R	TCKVF200.30RFFA
	TCKVF200.30RMMA
KVF200.50R	TCKVF200.50RFFA
	TCKVF200.50RMMA

## BUCKET



Code
CKV200

## STEP UNIT



Code
CEKV200

To install in the changes of height with cascaded slope.

## SLOPE DESIGNS

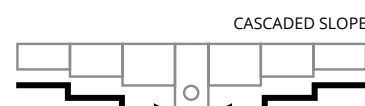
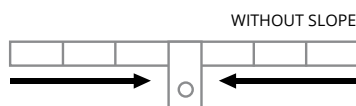

# SUMP UNITS

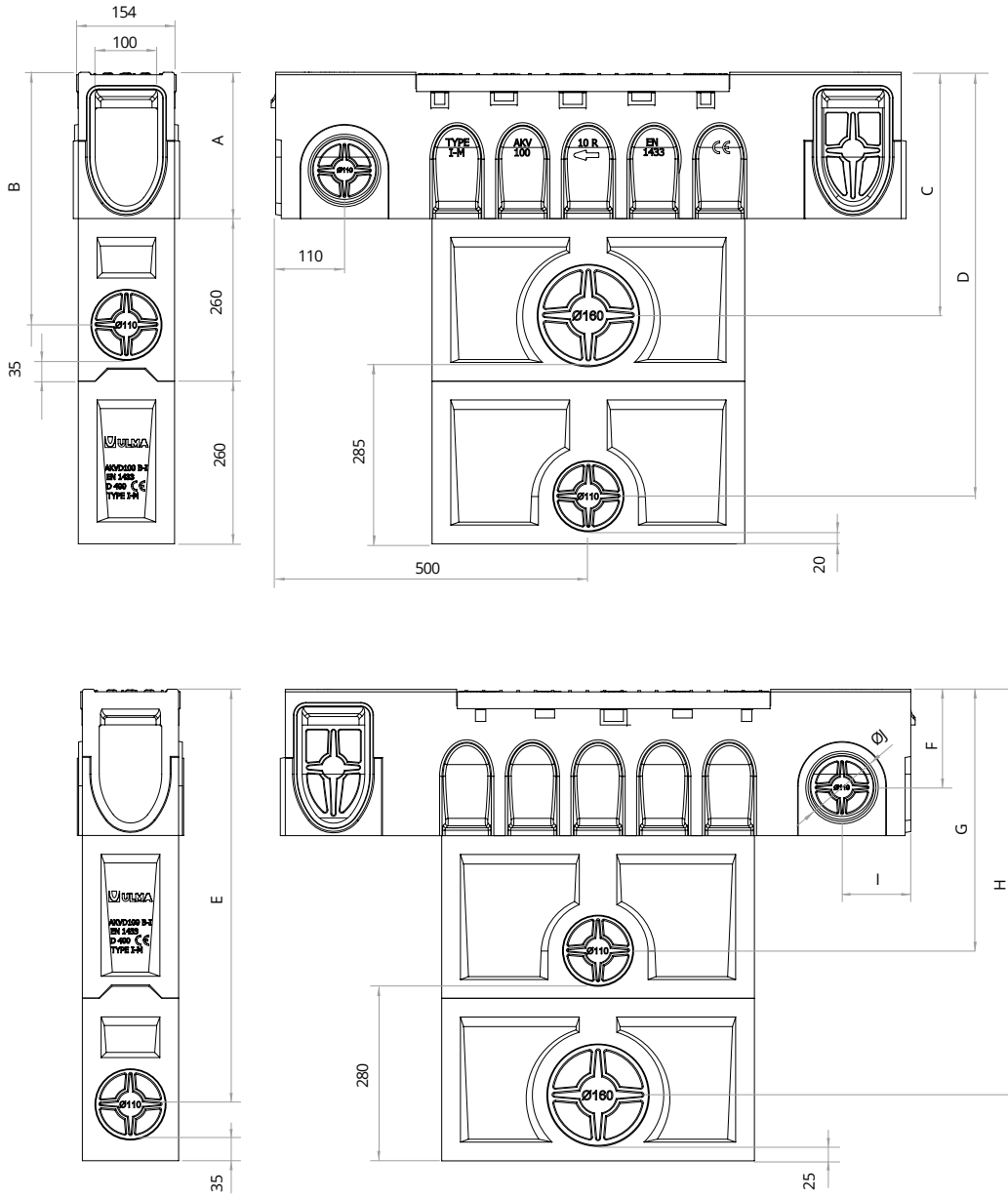

Sump Units Superior	A	B	C	D	E	F	G	H	I	J
	mm	mm	mm	mm	mm	mm	mm	mm	mm	mm
AKVDH100MF10RS	235	403	388	677	663	157	417	648	110	110

Possibility of installing upper body plus base or upper body, plus intermediate, plus base.

# SUMP UNITS

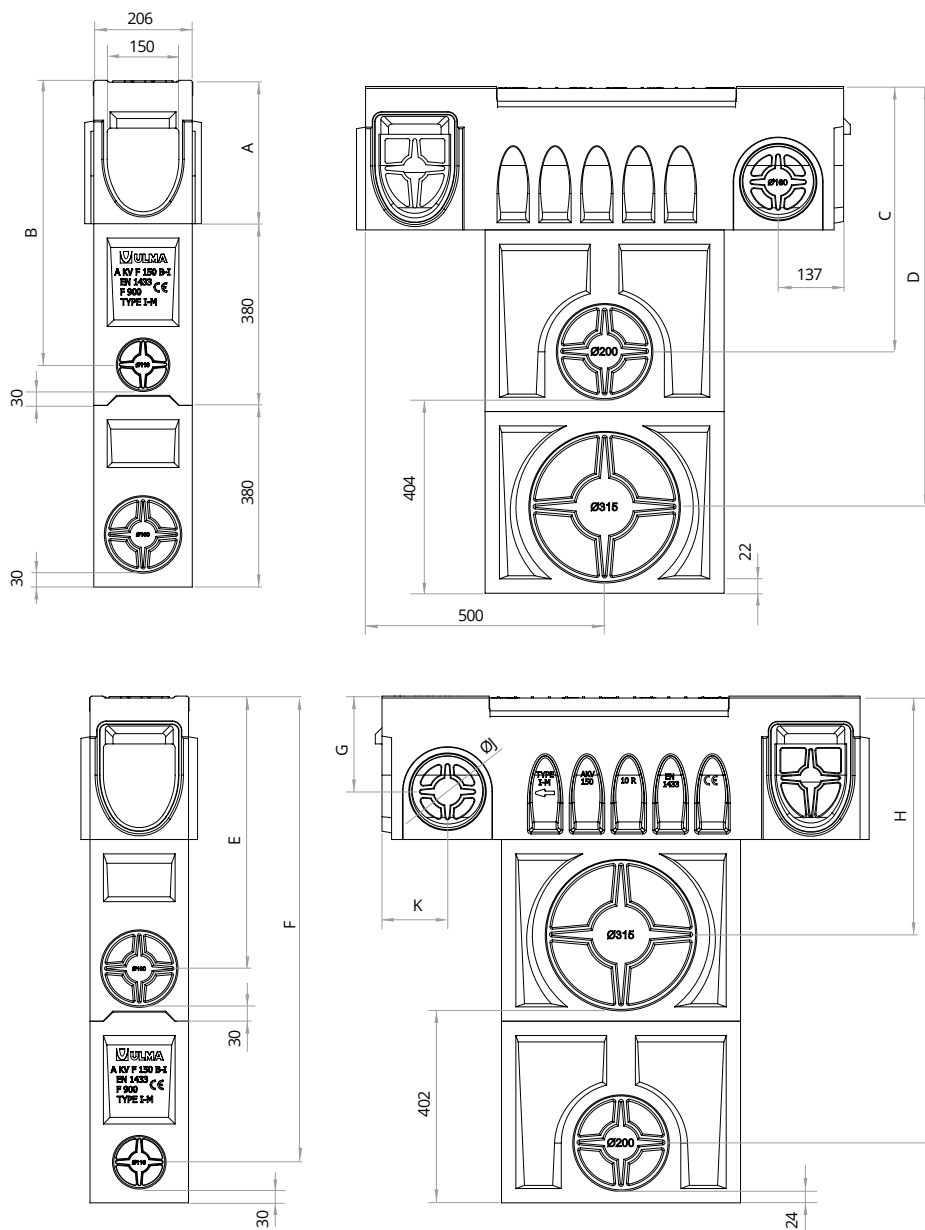

	Sump Units Superior	A mm	B mm	C mm	D mm	E mm	F mm	G mm	H mm	I mm	J mm	K mm
CITY	AKVFDH150MF10RS	270	564	523	848	539	944	170	469	903	160	137
	AKVFDH150MF20RS	370	664	623	948	639	1044	250	569	1003	200	162
	AKVFDH150MF30RS	470	764	723	1048	739	1144	291	669	1103	315	203
TRAFFIC	AKVFD150MF10RS	270	564	523	848	539	944	170	469	903	160	137
	AKVFD150MF20RS	370	664	623	948	639	1044	250	569	1003	200	162
	AKVFD150MF30RS	470	764	723	1048	739	1144	291	669	1103	315	203
INDUSTRY	AKVE150MF10RS	280	574	533	858	549	954	180	479	913	160	137
	AKVE150MF20RS	380	674	633	958	649	1054	260	579	1013	200	162
	AKVE150MF30RS	480	774	733	1058	749	1154	301	679	1113	315	203
CIVIL	AKVF150MF10RS	300	594	553	878	569	974	200	499	933	160	137
	AKVF150MF20RS	400	694	653	978	669	1074	280	599	1033	200	162
	AKVF150MF30RS	500	794	753	1078	769	1174	321	699	1133	315	203

Possibility of installing upper body plus base or upper body, plus intermediate, plus base.

# SUMP UNITS

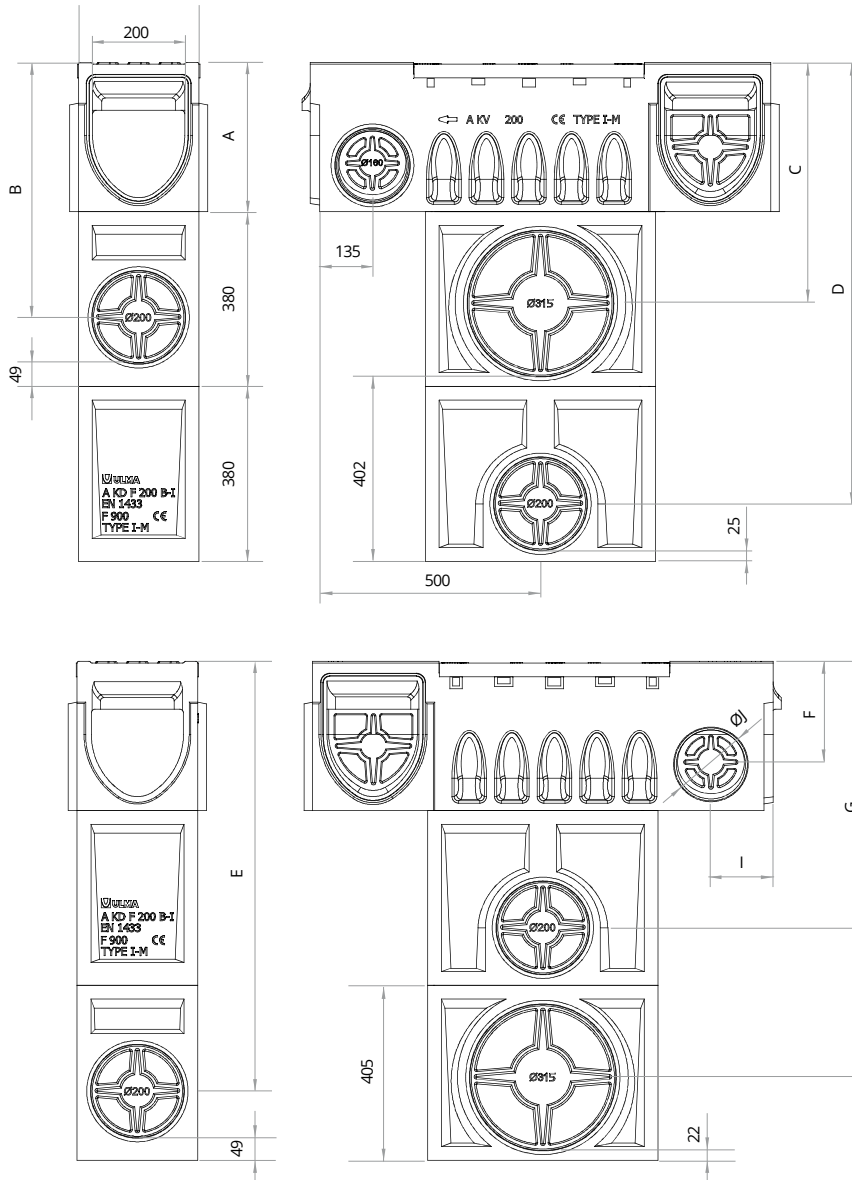

	Sump Units Superior	A mm	B mm	C mm	D mm	E mm	F mm	G mm	H mm	I mm	J mm
CITY	AKVFDH200MF10RS	305	532	502	937	912	199	557	882	135	160
	AKVFDH200MF30RS	505	732	702	1137	1112	301	757	1082	203	315
	AKVFDH200MF50RS	705	932	902	1337	1312	473	957	1282	253	400
TRAFFIC	AKVFD200MF10RS	305	532	502	937	912	199	557	882	135	160
	AKVFD200MF30RS	505	732	702	1137	1112	301	757	1082	203	315
	AKVFD200MF50RS	705	932	902	1337	1312	473	957	1282	253	400
INDUSTRY	AKVE200MF10RS	300	527	497	932	907	194	552	877	135	160
	AKVE200MF30RS	500	727	697	1132	1107	296	752	1077	203	315
	AKVE200MF50RS	700	927	897	1332	1307	468	952	1277	253	400
CIVIL	AKVF200MF10RS	325	552	522	957	932	219	577	902	135	160
	AKVF200MF30RS	525	752	722	1157	1132	321	777	1102	203	315
	AKVF200MF50RS	725	952	922	1357	1332	493	988	1302	253	400

Possibility of installing upper body plus base or upper body, plus intermediate, plus base.





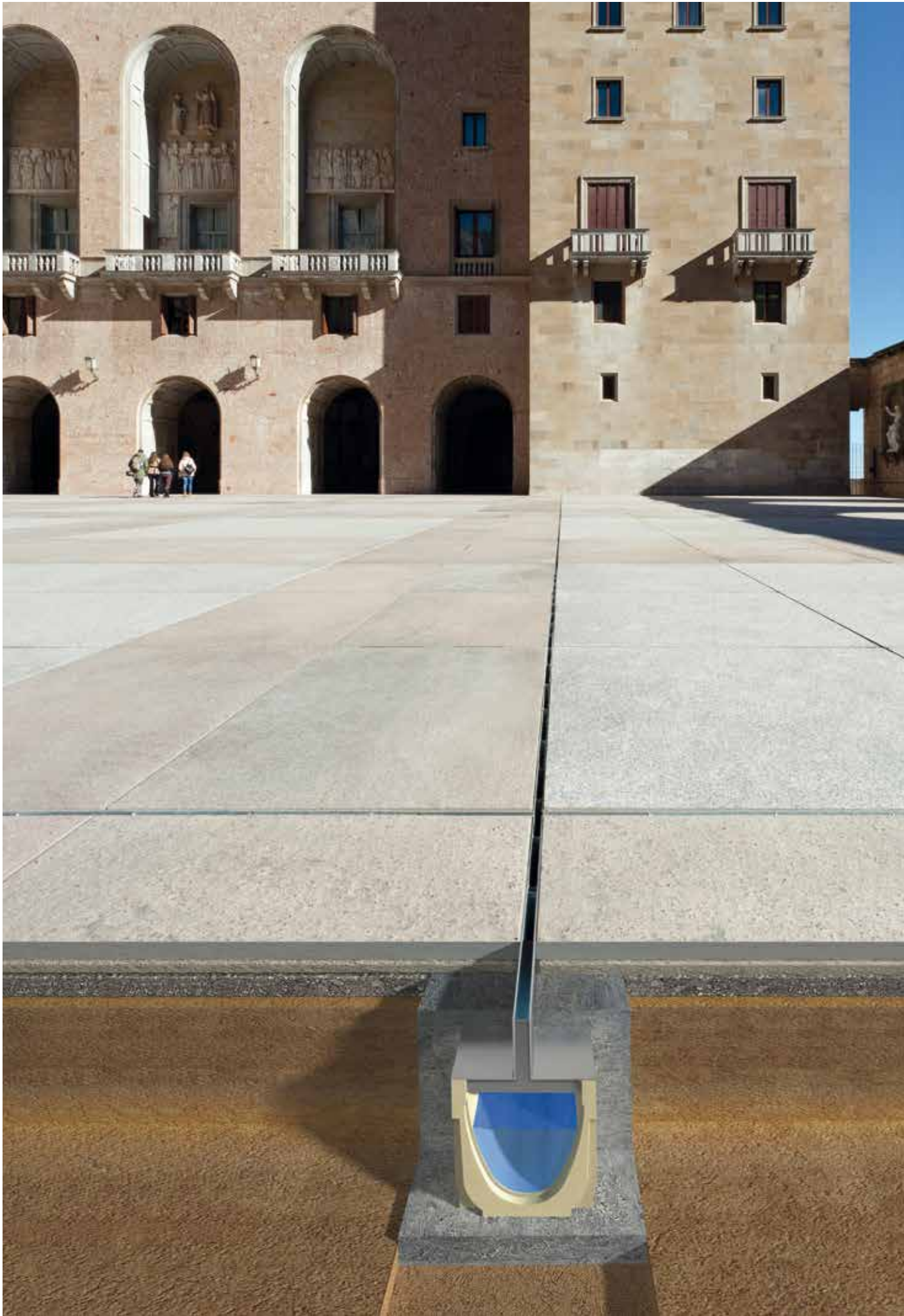

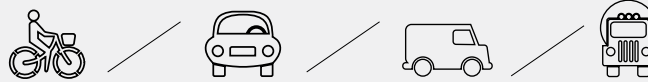

# SLOT

## GRATINGS

The SLOT Drainage is part of an integral system, consisting of a discrete slot, a channel body and an access unit for an optimal maintenance of the drainage system. It is an inverted "T" or "L" shaped grating model, that stands out mainly for its aesthetics, since it integrates perfectly in the pavement (either concrete, paving stone or tiles) achieving a total blend with the urban landscape.

Supports a load class up to D-400 according to Standard EN1433.

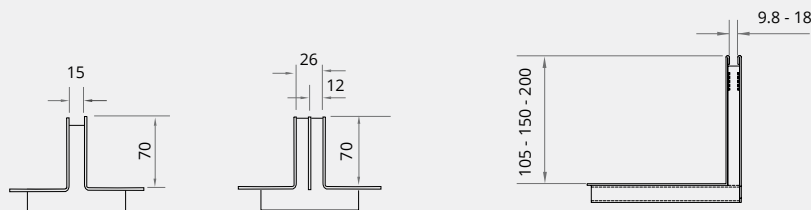

Width 100 / 150 / 200

Width 100 / 150 / 200

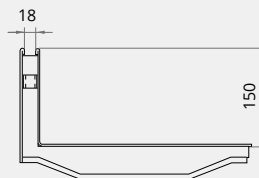

Width 250 / 300

# GRATINGS CLASSES

The grating can be either single or double slot for greater hydraulic efficiency, and offset to install close to walls.



**SINGLE SLOT**  
Aesthetic solution.



**DOUBLE SLOT**  
Same solution with greater hydraulic capacity.



**OFFSET SLOT GRATE**  
Ideal solution for areas near walls.

# MATERIAL

Available in GALVANIZED STEEL as well as in STAINLESS STEEL (AISI 304 and AISI 316L) for the most demanding of hygiene.



Please consult our technical department with any queries regarding the application of materials and installation.

# DRAINAGE SYSTEM

## WITH SLOT GRATING

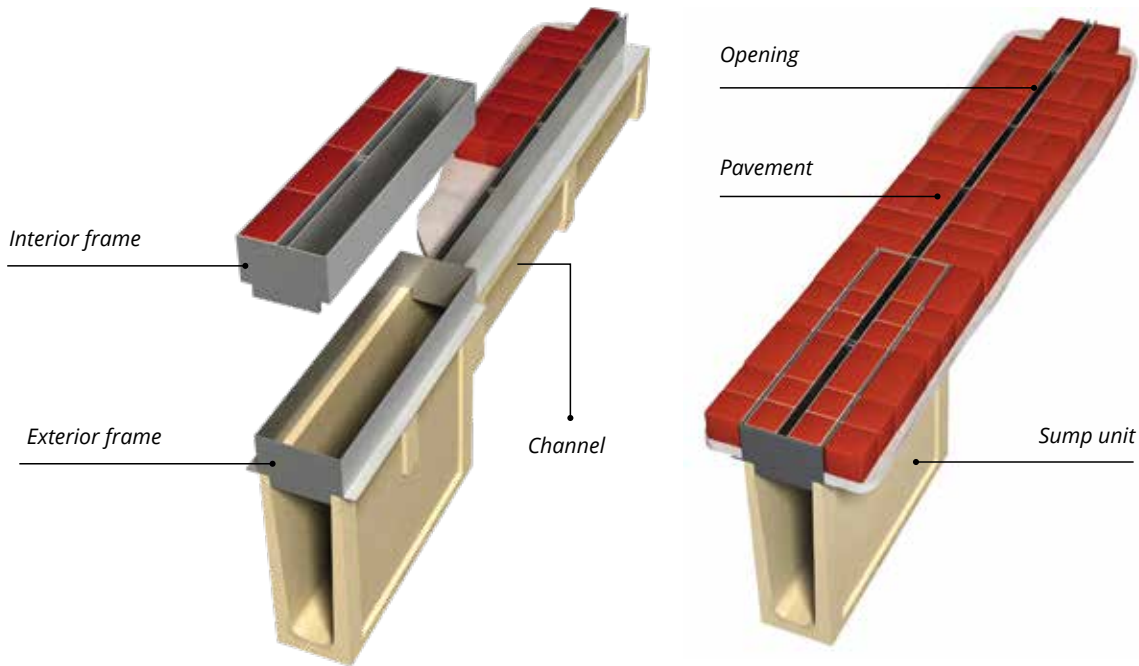

# MAINTENANCE

Steps to follow for the correct removal of the access unit and cleaning of the drainage system.

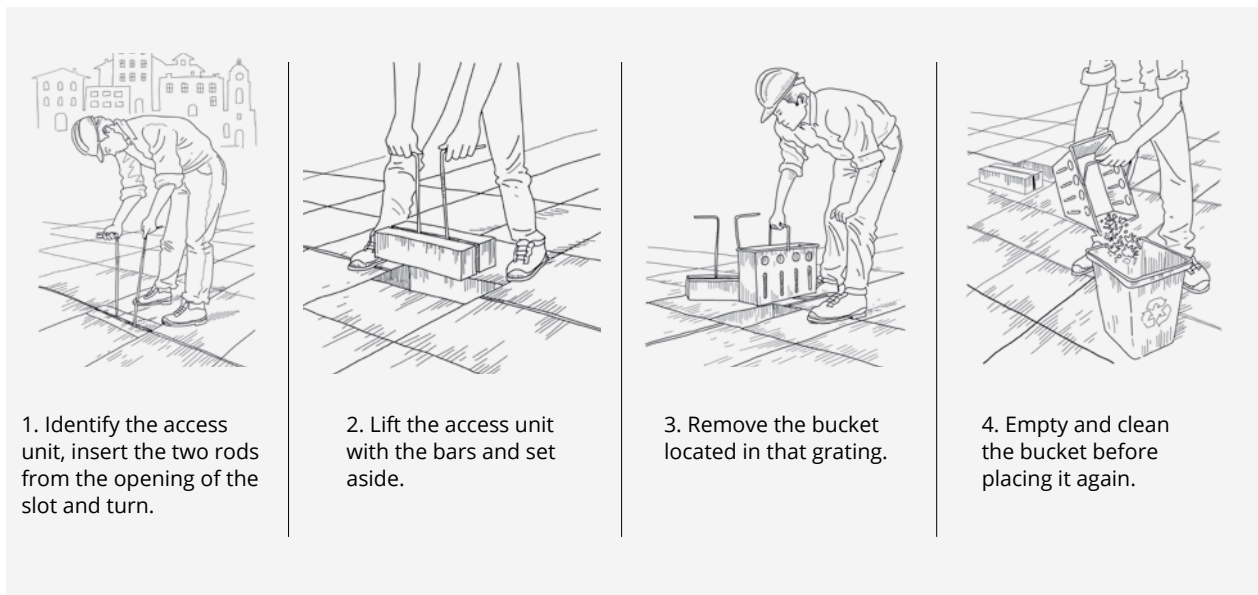

# INSTALLATION DETAILS

## URBAN PAVER

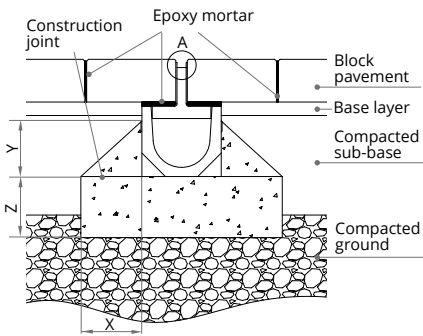

**A15 - B125 - C250**

Load class EN 1433 Standard		A15	B125	C250
Type of concrete EN 206-1 Standard		HM-25 (X0)	HM-25 (X0)	HM-25 (X0)
Minimum distances (mm)	X	100	100	150
	Y	100*	100*	100*
	Z	100	100	150

\* In case of an incorrect compaction of the soil, the concrete embracement must be made up to the pavement level.

## ASPHALT

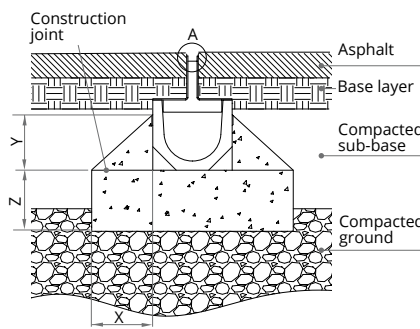

## CONCRETE

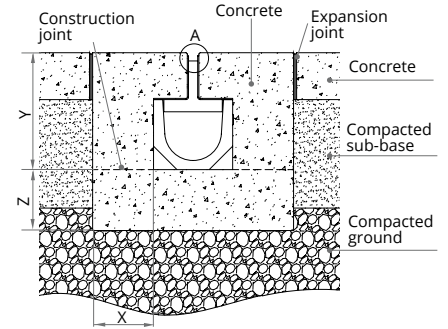

**A15 - B125 - C250**

Load class EN 1433 Standard		A15	B125	C250
Type of concrete EN 206-1 Standard		HM-25 (X0)	HM-25 (X0)	HM-25 (X0)
Minimum distances (mm)	X	100	100	150
	Y	Channel height + grating + 3 - 5 mm		
	Z	100	100	150

## TRAFFIC PAVER

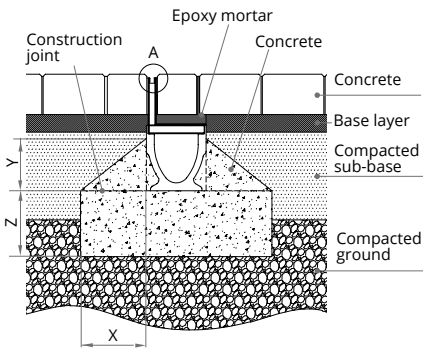

**A15 - B125 - C250**

Load class EN 1433 Standard		A15	B125	C250
Type of concrete EN 206-1 Standard		HM-25 (X0)	HM-25 (X0)	HM-25 (X0)
Minimum distances (mm)	X	100	100	150
	Y	Above the arcs*		
	Z	100	100	150

\* In case of an incorrect compaction of the soil, the concrete embracement must be made up to the pavement level.

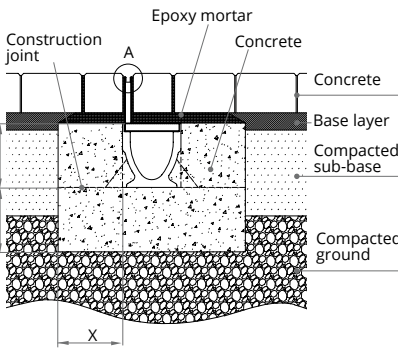

**D400**

Load class EN 1433 Standard		A15	B125	C250	D400
Type of concrete EN 206-1 Standard					HM-25 (X0)
Minimum distances (mm)	X				150
	Y				Up to the pavement level
	Z				150

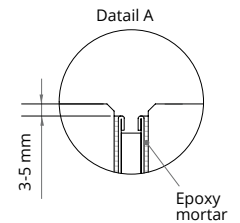

## TRAFFIC ASPHALT

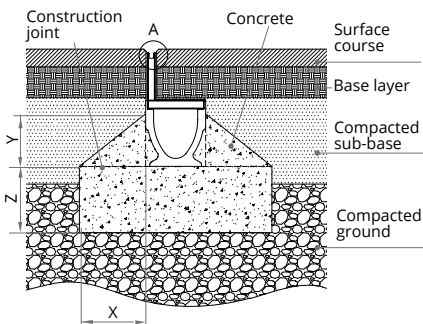

**A15 - B125 - C250**

Load class EN 1433 Standard		A15	B125	C250
Type of concrete EN 206-1 Standard		HM-25 (X0)	HM-25 (X0)	HM-25 (X0)
Minimum distances (mm)	X	100	100	150
	Y	Above the arcs*		
	Z	100	100	150

\* In case of an incorrect compaction of the soil, the concrete embracement must be made up to the pavement level.

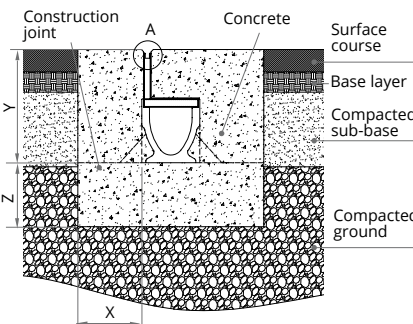

**D400**

Load class EN 1433 Standard		A15	B125	C250	D400
Type of concrete EN 206-1 Standard					HM-25 (X0)
Minimum distances (mm)	X				150
	Y				Channel height + grating + 3 - 5 mm
	Z				150

## CONCRETE

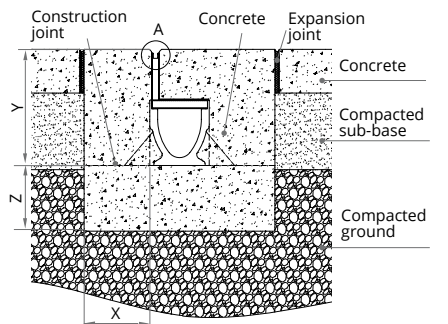

**D400**

Load class EN 1433 Standard		A15	B125	C250	D400
Type of concrete EN 206-1 Standard		HM-25 (X0)	HM-25 (X0)	HM-25 (X0)	HM-25 (X0)
Minimum distances (mm)	X	100	100	150	150
	Y	Channel height + grating + 3 - 5 mm			
	Z	100	100	150	150

Load Class  
up to C250  
EN-1433 Standard

# URBAN



Slot grating in an inverted "T" shape that stands out for its aesthetic, since it integrates perfectly in the pavement (concrete, paving stone or tile) achieving a total blend with the urban landscape. It can be a single slot or a double slot for greater hydraulic efficiency. Supports a load class up to C-250 according to Standard EN1433.

## GRATINGS

Material	Width mm	Code	Type	L mm	A mm	B mm	C mm	Intake area cm <sup>2</sup> /ml	Compatible system
GALVANISED STEEL	100	GR100UOC	SIMPLE	1000	130	15	70	150	SELF/U
		GDR100UOC	DOUBLE	1000	130	12 x 2	70	240	SELF/U
	150	GR150UOC	SIMPLE	1000	200	15	70	150	SELF/U
		GDR150UOC	DOUBLE	1000	200	12 x 2	70	240	SELF/U
	200	GR200UOC	SIMPLE	1000	260	15	70	150	SELF/U
		GDR200UOC	DOUBLE	1000	260	12 x 2	70	240	SELF/U
STAINLESS STEEL	100	IR100UOC	SIMPLE	1000	130	15	70	150	SELF/U
		IDR100UOC	DOUBLE	1000	130	12 x 2	70	240	SELF/U
	150	IR150UOC	SIMPLE	1000	200	15	70	150	SELF/U
		IDR150UOC	DOUBLE	1000	200	12 x 2	70	240	SELF/U
	200	IR200UOC	SIMPLE	1000	260	15	70	150	SELF/U
		IDR200UOC	DOUBLE	1000	260	12 x 2	70	240	SELF/U

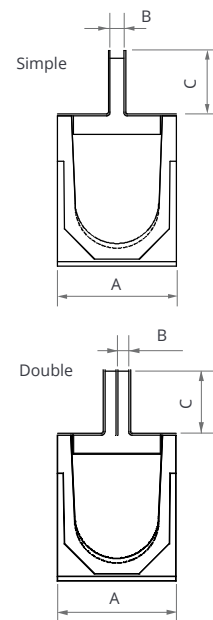

\*Customised options available

## ACCESS UNITS

Material	Width mm	Code	Type	L mm	A mm	B mm	C mm	Intake area cm <sup>2</sup> /ml	Compatible system
GALVANISED STEEL	100	GR100UOCMA	SIMPLE	500	178	15	70	150	SELF/U
		GDR100UOCMA	DOUBLE	500	178	12 x 2	70	240	SELF/U
	150	GR150UOCMA	SIMPLE	500	250	15	70	150	SELF/U
		GDR150UOCMA	DOUBLE	500	250	12 x 2	70	240	SELF/U
	200	GR200UOCMA	SIMPLE	500	310	15	70	150	SELF/U
		GDR200UOCMA	DOUBLE	500	310	12 x 2	70	240	SELF/U
STAINLESS STEEL	100	IR100UOCMA	SIMPLE	500	178	15	70	150	SELF/U
		IDR100UOCMA	DOUBLE	500	178	12 x 2	70	240	SELF/U
	150	IR150UOCMA	SIMPLE	500	250	15	70	150	SELF/U
		IDR150UOCMA	DOUBLE	500	250	12 x 2	70	240	SELF/U
	200	IR200UOCMA	SIMPLE	500	310	15	70	150	SELF/U
		IDR200UOCMA	DOUBLE	500	310	12 x 2	70	240	SELF/U

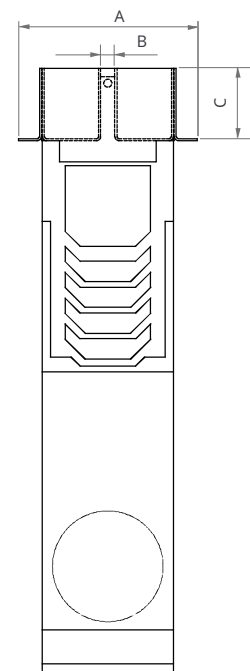

\*Customised options available



Application detail

Inverted "L" shape slot grating that stands out for its aesthetic, since it integrates perfectly in the pavement (concrete, paving stone or tile) achieving a total blend with the urban landscape. It is especially designed to be installed in areas close to walls. Supports a load class up to D-400 according to Standard EN1433.

## GRATINGS

Material	Width mm	Code	Type	L mm	A mm	B mm	C mm	Intake area cm <sup>2</sup> /ml	Compatible system		
GALVANISED STEEL	100	GRL100RODM	OFFSET	500	131	9,8	105	98	MULTIV100		
		GRL100ROD		1000	131	9,8	105	98	MULTIV100		
		GRL100RODE18		1000	131	18	105	180	MULTIV100		
		GRL100RODH150		1000	131	9,8	150	98	MULTIV100		
		GRL100RODH150E18		1000	131	18	150	180	MULTIV100		
		GRL100RODH200		1000	131	9,8	200	98	MULTIV100		
		GRL100RODH200E18		1000	131	18	200	180	MULTIV100		
	150	GRL150RODM		500	181	9,8	105	98	MULTIV150		
		GRL150ROD		1000	181	9,8	105	98	MULTIV150		
		GRL150RODE18		1000	181	18	105	180	MULTIV150		
		GRL150RODH150		1000	181	9,8	150	98	MULTIV150		
		GRL150RODH150E18		1000	181	18	150	180	MULTIV150		
		GRL150RODH200		1000	181	9,8	200	98	MULTIV150		
		GRL150RODH200E18		1000	181	18	200	180	MULTIV150		
	200	GRL200RODM		500	231	9,8	105	98	MULTIV200		
		GRL200ROD		1000	231	9,8	105	98	MULTIV200		
		GRL200RODE18		1000	231	18	105	180	MULTIV200		
		GRL200RODH150		1000	231	9,8	150	98	MULTIV200		
		GRL200RODH150E18		1000	231	18	150	180	MULTIV200		
		GRL200RODH200		1000	231	9,8	200	98	MULTIV200		
		GRL200RODH200E18		1000	231	18	200	180	MULTIV200		
	250	GRL250FOD		1000	305	18	150	180	S300F/F250K		
	300	GRL300FOD		1000	355	18	150	180	S350F/F300K		
	STAINLESS STEEL	100		IRL100RODM	OFFSET	500	131	9,8	105	98	MULTIV100
				IRL100ROD		1000	131	9,8	105	98	MULTIV100
				IRL100RODE18		1000	131	18	105	180	MULTIV100
				IRL100RODH150		1000	131	9,8	150	98	MULTIV100
				IRL100RODH150E18		1000	131	18	150	180	MULTIV100
IRL100RODH200			1000	131		9,8	200	98	MULTIV100		
IRL100RODH200E18			1000	131		18	200	180	MULTIV100		
150		IRL150RODM	500	181		9,8	105	98	MULTIV150		
		IRL150ROD	1000	181		9,8	105	98	MULTIV150		
		IRL150RODE18	1000	181		18	105	180	MULTIV150		
		IRL150RODH150	1000	181		9,8	150	98	MULTIV150		
		IRL150RODH150E18	1000	181		18	150	180	MULTIV150		
		IRL150RODH200	1000	181		9,8	200	98	MULTIV150		
		IRL150RODH200E18	1000	181		18	200	180	MULTIV150		
200		IRL200RODM	500	231		9,8	105	98	MULTIV200		
		IRL200ROD	1000	231		9,8	105	98	MULTIV200		
		IRL200RODE18	1000	231		18	105	180	MULTIV200		
		IRL200RODH150	1000	231		9,8	150	98	MULTIV200		
		IRL200RODH150E18	1000	231		18	150	180	MULTIV200		
		IRL200RODH200	1000	231		9,8	200	98	MULTIV200		
		IRL200RODH200E18	1000	231		18	200	180	MULTIV200		
250		IRL250FOD	1000	305		18	150	180	S300F/F250K		
300		IRL300FOD	1000	355		18	150	180	S350F/F300K		

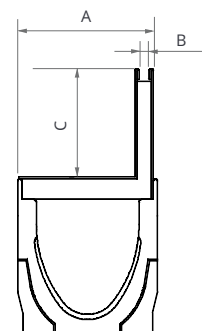

\*Customised options available

# ACCESS UNITS

Material	Width mm	Code	Type	L mm	A mm	B mm	C mm	Intake area cm <sup>2</sup> /ml	Compatible system
GALVANISED STEEL	100	GRL100RODMA	OFFSET	500	128	9,8	105	98	MULTIV100
		GRL100RODMAE18		500	128	18	105	180	MULTIV100
		GRL100RODMAH150		500	128	9,8	150	98	MULTIV100
		GRL100RODMAH150E18		500	128	18	150	180	MULTIV100
		GRL100RODMAH200		500	128	9,8	200	98	MULTIV100
		GRL100RODMAH200E18		500	128	18	200	180	MULTIV100
	150	GRL150RODMA		500	178	9,8	105	98	MULTIV150
		GRL150RODMAE18		500	178	18	105	180	MULTIV150
		GRL150RODMAH150		500	178	9,8	150	98	MULTIV150
		GRL150RODMAH150E18		500	178	18	150	180	MULTIV150
		GRL150RODMAH200		500	178	9,8	200	98	MULTIV150
		GRL150RODMAH200E18		500	178	18	200	180	MULTIV150
	200	GRL200RODMA		500	228	9,8	105	98	MULTIV200
		GRL200RODMAE18		500	228	18	105	180	MULTIV200
		GRL200RODMAH150		500	228	9,8	150	98	MULTIV200
		GRL200RODMAH150E18		500	228	18	150	180	MULTIV200
		GRL200RODMAH200		500	228	9,8	200	98	MULTIV200
		GRL200RODMAH200E18		500	228	18	200	180	MULTIV200
	250	GRL250FODMA		500	302	18	150	180	S300F/F250K
	300	GRL300FODMA		500	352	18	150	180	S350F/F300K
	STAINLESS STEEL	100		IRL100RODMA	OFFSET	500	128	9,8	105
IRL100RODMAE18			500	128		18	105	180	MULTIV100
IRL100RODMAH150			500	128		9,8	150	98	MULTIV100
IRL100RODMAH150E18			500	128		18	150	180	MULTIV100
IRL100RODMAH200			500	128		9,8	200	98	MULTIV100
IRL100RODMAH200E18			500	128		18	200	180	MULTIV100
150		IRL150RODMA	500	178		9,8	105	98	MULTIV150
		IRL150RODMAE18	500	178		18	105	180	MULTIV150
		IRL150RODMAH150	500	178		9,8	150	98	MULTIV150
		IRL150RODMAH150E18	500	178		18	150	180	MULTIV150
		IRL150RODMAH200	500	178		9,8	200	98	MULTIV150
		IRL150RODMAH200E18	500	178		18	200	180	MULTIV150
200		IRL200RODMA	500	228		9,8	105	98	MULTIV200
		IRL200RODMAE18	500	228		18	105	180	MULTIV200
		IRL200RODMAH150	500	228		9,8	150	98	MULTIV200
		IRL200RODMAH150E18	500	228		18	150	180	MULTIV200
		IRL200RODMAH200	500	228		9,8	200	98	MULTIV200
		IRL200RODMAH200E18	500	228		18	200	180	MULTIV200
250		IRL250FODAM	500	302		18	150	180	S300F/F250K
230		IRL300FODAM	500	352		18	150	180	S350F/F300K

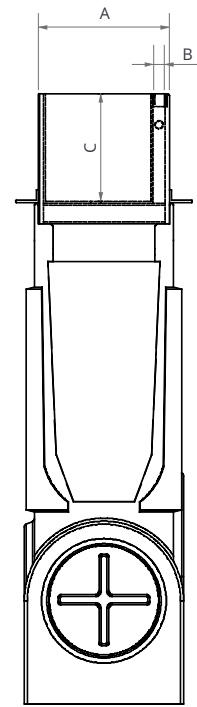

\*Customised options available



Application detail







Mahou  
SIN

adidas adidas adidas adidas

PREPÁRATE PREPÁRATE

Asociación de Fútbol Profesional



# OTHER SOLUTIONS

---

# BEACONS



# CABLE DUCTS



# DRAINAGE SOLUTIONS FOR TRAMS



# ELECTRICAL SUBSTATIONS



# INDUSTRIAL SKIRTING



# TRENCHES



# RUNWAY





# ULMA® DRAINAGE SYSTEM INSTALLATION INSTRUCTIONS

## 1. Initial conditions

The purpose of these instructions is to provide general information for successfully installing and operating ULMA Architectural Solutions' channel systems. The construction details refer to specific soil conditions, meaning professional advice is recommended for particular soils and/or local circumstances. We have a team of professionals with extensive experience that can provide advice and a personalised service to our customers in this regard.

The construction details presented are generic and aim to cover the broadest range of construction options, all with the highest guarantees possible. However, this does not exempt the Designer or Project Managers from checking these construction recommendations and making sure they are compatible with the nature of the soil.

This guide provides the basic instructions to ensure the correct operation of the system. Additional reinforcement may be required in special cases or soils with different characteristics, increasing the concrete bedding section or even installing rebars.

Seek advice from the engineering department in order to determine the size of any rebars and how they should be configured. ULMA Architectural Solutions' channelling system has been designed and tested under the stringent provisions of STANDARD EN1433, thus ensuring compliance with requirements for collecting and discharging surface water and absorbing loads generated on flooring. The following conditions must be met in order for the drainage channel system to work properly:

1. Correct design of the project
2. Proper on-site planning
3. Specialist installation
4. Regular maintenance

The following regulations apply to the installation of ULMA Architectural Solutions' drainage systems:

- **UNE EN 1433:2002 + DIN V 19580**  
"Drainage channel systems for circulation areas" with regard to classifying and installing the corresponding channel systems.
- **Structural Concrete Instruction (EHE)**, mandatory according to Royal Decree 2661/1998 of 11 December.
- **CE marking of drainage channel systems**, according to Resolution of 12 June 2003, of the Directorate General of Technology Policy. State Journal no. 165 for harmonised standard EN 1433.
- **Directive 89/106/EC** on construction product marking.
- **Technical Building Code According to Royal Decree 314/2006, of 17 March 2006**, on overall appearance, and specifically Basic Health Document part 5.

## 2. General installation instructions

### 2.1 PREPARATORY WORK

The soil must be in good condition, in order to avoid future problems of sinkage and breakage of the channels. The soil should be well compacted if there have been any earthworks, eliminating any soft areas.

The compaction level should be of over 90% of the Proctor standard test and a 95-100% degree of compaction will be required for airports and roads with intense, heavy traffic.

## 2.2. PREPARING THE TRENCH

Prepare the trench for the base. The trench should be excavated with levelling according to the slope in question, always taking into account dimensions X, Y, Z, as set out in the installation instructions for the channel used.

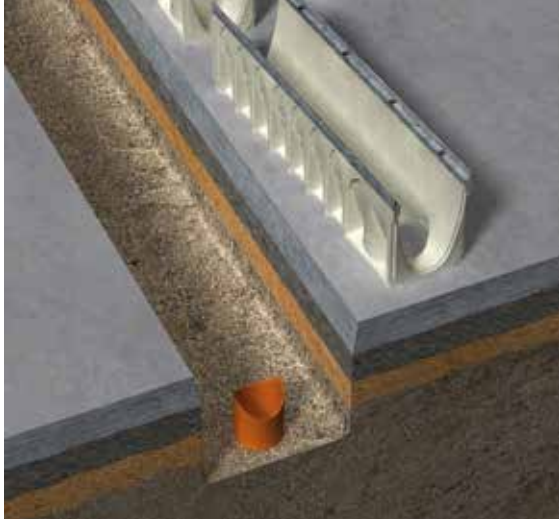

## 2.3. SUB-BASE CONCRETE LAYER

Install a sub-base concrete layer and/or a base waterproofing fabric for the channel's foundations.

## 2.4. POSITIONING THE CHANNELS

Establish an alignment line and prepare the channels along the trench. Check that the arrow on the sides of the channels points to the water discharge point

Open the outputs, always drilling the perimeter of the pre-marked output every 5-6 cm or cutting with an angle grinder.

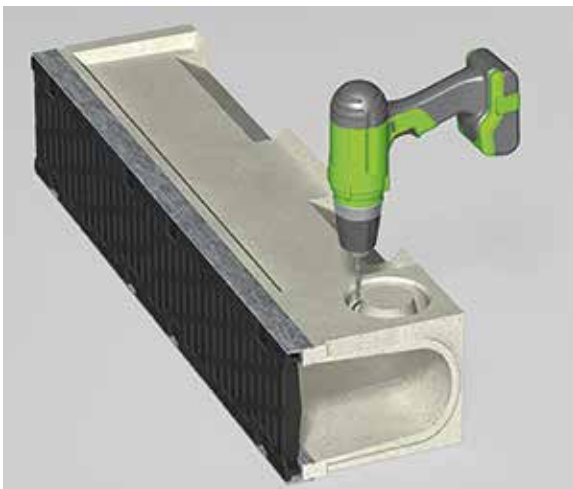

Pour the concrete (min. HM25) at the base of the trench, checking the thickness required in the relevant drawings, and position the channels before it starts to set. The choice of materials, especially the concrete, is determined by environmental conditions at the place of installation.

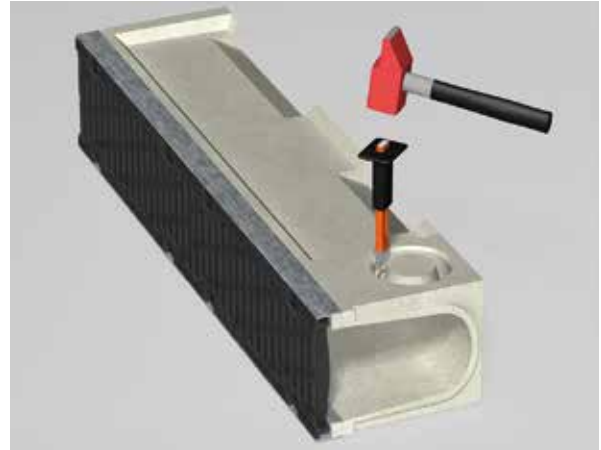

**The channels must be fitted on the concrete base without leaving any gaps**, taking into account the placement direction shown by the arrow moulded on the channel (=direction of flow).

Installation must begin at the lowest point, i.e. at the passage to the drain pipe or collector box, where appropriate.

Check the alignment along the trench.

See chapter **3.13 Sealing joints between channels** in these Installation Instructions. This procedure does not guarantee total waterproofing of the drainage line, meaning a waterproofing layer must be provided under the channel when installing in places with high waterproofing requirements, such as petrol stations or roofs of buildings. See chapter **3.4. Channels in places with high waterproofing requirements** in these Installation Instructions.

## 2.5. CONCRETE BEDDING

Before pouring the concrete for the reinforcement bedding, fit timber battens or protect the gratings with plastic in the channels, thus preventing deformation that will prevent the gratings from being installed.

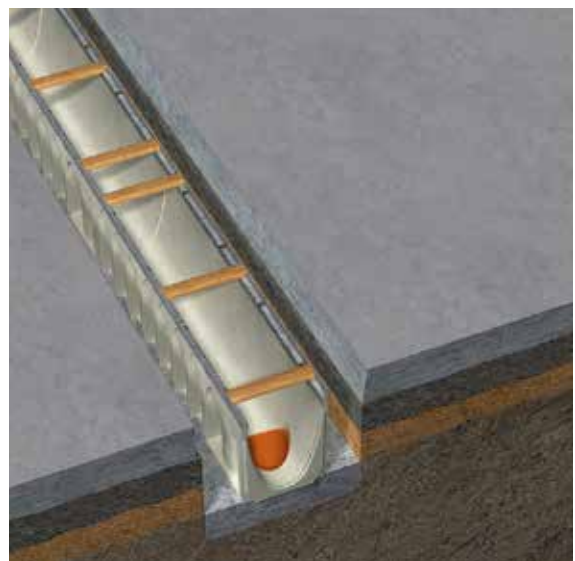

Pour the concrete through the sides of the channel, making the bedding as shown in the installation drawing.



It is very important to lay both layers within a reasonable time in order to ensure adhesion where two layers of concrete meet.

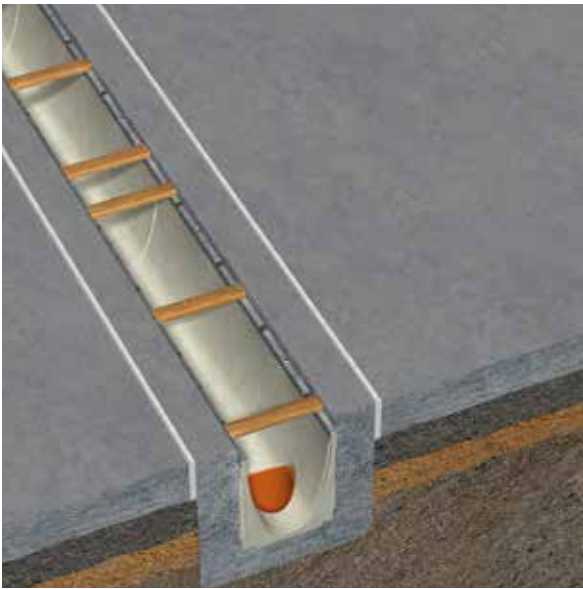

Where necessary, the “Y” measurement for the side height of the stabilising base relative to the channel body (as shown in the installation details established by ULMA Architectural Solutions) should be adapted on site, in accordance with the construction height of the channel body and the thickness of the flooring that follows it.

If necessary, install the mesh and pour the entire concrete bedding at once.

## 2.6. POSITIONING THE GRATINGS

Secure the gratings using their fixing system, applying a tightening torque to prevent the grating from moving after vehicles have passed over it. Installing the right fixing system for each use is essential to ensure that the system works correctly. See fixing systems.



## 2.7. SAFETY MEASURES

The channels must be duly reinforced against horizontal loads for the duration of flooring work on the adjacent sides of the channel, e.g. by installing gratings on the channels (if not already installed).

Mechanical damage to the channels must be avoided when finishing the surfaces adjacent to the channel. The movement of soil compacting elements must therefore be studied in detail before, during and after installing the channel's bedding.

Once finished, the flooring next to the channel must be 3 to 5 mm higher than the channel itself, including the thickness of the grating, and its surface must not cause any slippage.

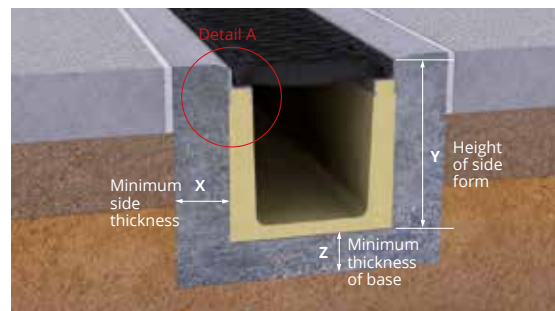

**Detail A**  
Channel with edge 3-5mm from the edge

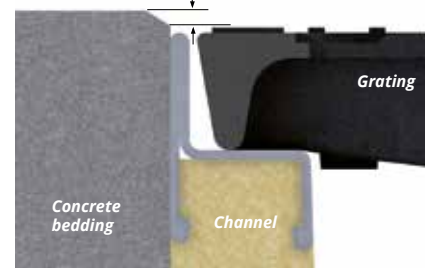

**Detail B**  
Channel without edge 3-5mm from the grating

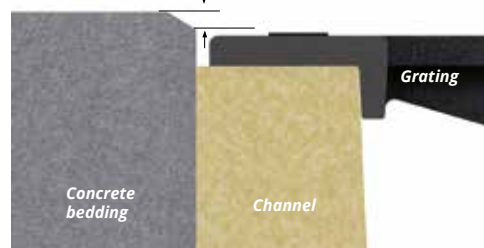

### 3. Special installation instructions

#### 3.1. EXPANSION AND CONTRACTION JOINTS

The Designer or Project Manager must draw up a suitable **joints plan** according to the construction details of the base slab and applicable standards and regulations, in order to avoid any tangential or perpendicular stress on the concrete bedding and channel assembly.

If the channels are installed on a concrete slab, expansion joints must be installed between the slab and the bedding in order to prevent expanding concrete from generating stresses on the sides of the channel.

Moreover, **expansion joints must be installed whenever paving, slabs** or asphalt are placed on top of a concrete slab, as described in the concrete installation instructions issued by ULMA Architectural Solutions.

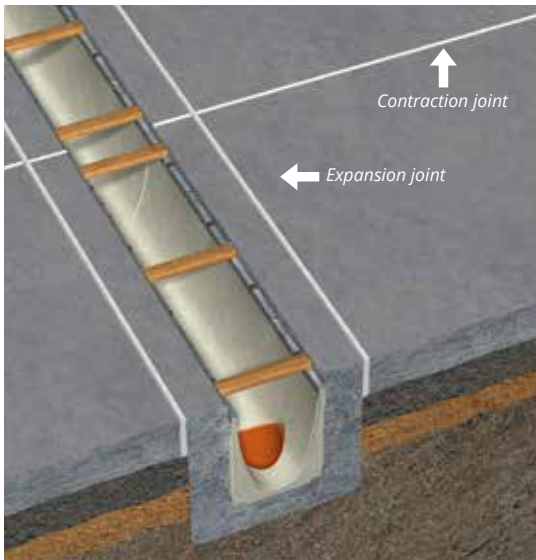

DO NOT place expansion joints **between the channel body and the adjacent flooring**. Such joints must always be between the bedding and the adjacent flooring.

On concrete floors, installing contraction joints every 6 or 7 metres is recommended in order to avoid uncontrolled cracking of the floor.

**All contraction joints running transversely to the channel** must coincide with the joint between the channels in order to avoid generating tangential forces.

#### 3.2. CHANNELS IN FLOORING WITH PAVING STONES

The joints between the channel body and large paving stones laid on a bed of sand must be **filled** in accordance with the installation details established by ULMA Architectural Solutions, and may use a high-strength material combined with cement or with a synthetic resin-based material, always in accordance with local requirements, in terms of load, strength, etc. Adhering the paving stones to the concrete means they will be an integral part of the channel. The size of the joint depends on the application instructions issued by the manufacturer.

#### 3.3. GROOVED CHANNELS

The **installation of channels with single-slot grating** on stone and/or tiled pavements will require the use of a reactive type epoxy adhesive (R) in the joints between the paving stone and grating, as well as in the points indicated in the construction details for this type of installation.

#### 3.4. CHANNELS IN SITES WITH HIGH WATERPROOFING REQUIREMENTS

Channels installed in places with high waterproofing requirements, such as filling stations, terraces, roofs, car parks, etc., must always be placed on a waterproofing layer and/or fabric, following the construction details for this type of installation.

#### 3.5. EXTENDING THE CONCRETE BEDDING

For better load distribution, we recommend extending the concrete bedding at the end of the channel section in longitudinal direction, as described below:

- Type of load A 15 - C 250  $\geq$  15.0 cm;
- Type of load D 400/E 600  $\geq$  25.0 cm;
- Type of load F 900  $\geq$  50.0 cm

#### 3.6. EXTREME LOADS

Areas subject to **extreme loads** include: Container terminals; truck operating areas; truck entrances to sites; busy loading and unloading areas with heavy duty trucks, and similar.

We recommend ULMA F 100 K - F 400 K or ULMA KompaqDrain® channel systems in these cases.

#### 3.7. CHANNELS IN MOTORWAYS AND HIGHWAYS

ULMA's KompaqDrain® system is the only valid system for areas that are transversal to traffic on motorways and highways.

#### 3.8. CHANNELS WITHOUT MESH

ULMA channels meet the requirements for load tests described in the standard, without the need for any reinforcements. Therefore, the minimum cross-sections required for installation do not require the use of reinforcements.

Reinforcements can be used to prevent any retraction of

the concrete bedding, thus ensuring the correct connection between the bedding and the channel in special situations of heavy loads or intense traffic. We recommend contacting the technical department if you have any doubts.

### 3.9. ZINC-COATED MATERIAL

We recommend not installing zinc-coated products in areas where contact with corrosive agents, such as cleaning products, chlorides, sulphates, acids, bleaches, etc. cannot be ruled out (e.g. swimming pools or marine environments).

### 3.10. STAINLESS STEEL

During installation, products made of stainless steel must be adequately protected against ferrous oxide dust in the environment, sparks caused by cutting metals, etc. The surfaces should be cleaned at regular intervals to maintain their appearance and prevent corrosion. The type of stainless steel will be chosen in accordance with environment where it is to be installed (AISI 304 for normal environments and AISI316 for marine environments).

### 3.11. CUTTING THE CHANNEL AND GRATING

All channel and grating elements can generally be cut to a suitable length on site. However, it should be remembered that at least one attachment point per grating should remain accessible. If necessary, remove the burrs from all cut metal edges and ensure there are no sharp edges.

Mitre joints are achieved by cutting the channels to the desired angle and abutting them or joining them with resin. Beveling channels for higher types of load (D400, E600 and F900) is NOT recommended. Mitre joints and couplings can be configured with connecting pipes.

### 3.12. MOULDED PREFORMS

In principle, vertical moulded preforms in polymer concrete will always be opened/hammered from inside to out. To do this, we recommend making a contour on the outside of the preform with boreholes, and hammering the weakened area with a mallet and chisel. Boreholes can be made with a hand drill.

### 3.13. SEALING JOINTS BETWEEN CHANNELS

#### PREPARING SURFACES

**Cleaning:** The polymer concrete substrate must be cleaned thoroughly before applying any of the sealing elements. The aim is to eliminate any elements that prevent direct contact between the sealing elements and the substrate.

All surfaces that are going to be in contact with the sealing elements must be cleaned (both the groove that will house the sealant and the two front faces of the channels to be joined).

There must be no dirt, dust, grease, oil or any other element wholly or partially covering the substrate and adversely affecting adhesion between the sealing elements and the substrate.

**Priming:** Applying a cleaning and activation product for priming is recommended once the sealing surfaces have been cleaned. There are specific products for each elastic sealant, which can be used to improve adhesion to the substrate.

It is usually enough to apply a coat of activating cleaner on the surfaces to be treated, and then leaving them to dry. This should be done using a brush, always following the manufacturer's instructions.

#### APPLYING SEALANT

Either a single-component product or a two-component product can be applied for elastic sealing.

The recommended single-component elastic sealant cures thanks to environmental humidity, and therefore has a variable curing period, depending on the humidity present in the environment.

The two-component elastic sealant recommended for this application is as valid as the single-component product, the only difference being the extra work involved in uniformly mixing the components beforehand, and the fact that workability and application time are limited.

**Single-component sealant:** Using a single-component sealant is recommended if curing time is not a critical element; in this case, the curing process can be around 2-3 mm after 24-48 hours, always depending on environmental humidity, and it can be applied without first mixing the components.

**Two-component sealant:** Applying a two-component sealant is recommended if a short or independent curing period is required, in this case consisting of the sealing element itself plus a product that accelerates the curing reaction.

#### REMARKS

Any action carried out with the recommended products must always be in keeping with the relevant Instructions, Technical Data Sheets and Safety Data Sheets issued by the manufacturer.

The reliability and durability of the sealing solution depend on the specific conditions of each work site: conception and design, conditions, care taken during installation, use and maintenance, local climatological conditions, etc.

Since ULMA Architectural Solutions has no influence over these aspects and cannot guarantee a working life for this sealant solution, it shall not be in any way liable in this regard, with its work being limited simply to recommending a suitable commercial sealant product.

# INSTALLATION DETAILS

## SELF System

EUROKIT | EUROSELF | EUROSELFV+ | DOMO | SELF | EUROSELF200 | SELF200 | SELF250 | SELF300

SELFK | SELF200K | SELF250K | SELF350K

### SELF PAVER

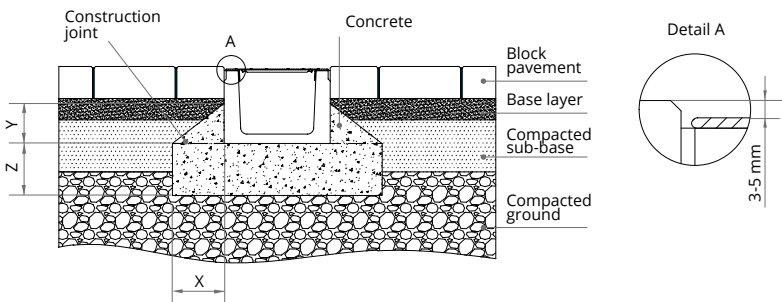

#### A15 - B125 - C250

Load class EN 1433 Standard	A15	B125	C250	D400	E600	F900
Type of concrete EN 206-1 Standard	HM-25 (X0)	HM-25 (X0)	HM-25 (X0)			
Minimum distances (mm)	X	100	100	150		
	Y	100*	100*	100*		
	Z	100	100	150		

\* In case of an incorrect compaction of the soil, the concrete embracement must be made up to the pavement level.

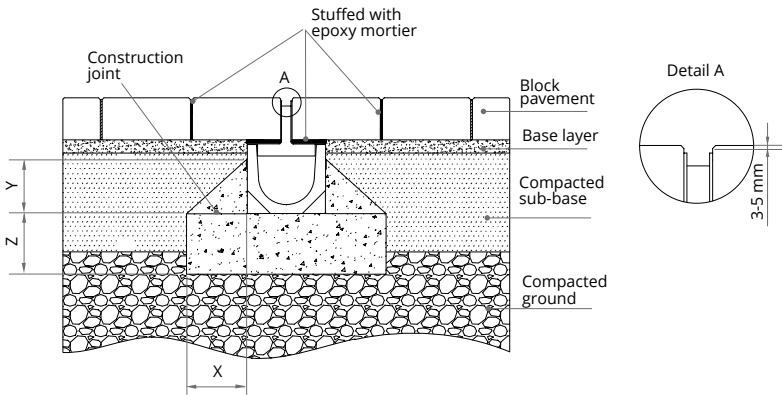

#### A15 - B125 - C250 with slot grating

Load class EN 1433 Standard	A15	B125	C250	D400	E600	F900
Type of concrete EN 206-1 Standard	HM-25 (X0)	HM-25 (X0)	HM-25 (X0)			
Minimum distances (mm)	X	100	100	150		
	Y	100*	100*	100*		
	Z	100	100	150		

\* In case of an incorrect compaction of the soil, the concrete embracement must be made up to the pavement level.

### SELF PAVER ONTO A LOAD-BEARING SLAB

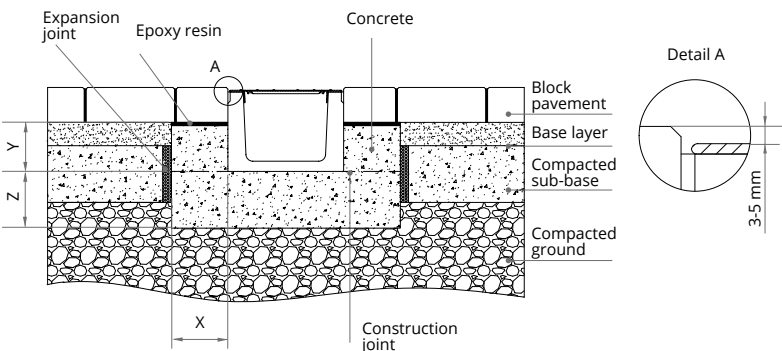

#### A15 - B125 - C250

Load class EN 1433 Standard	A15	B125	C250	D400	E600	F900
Type of concrete EN 206-1 Standard	HM-25 (X0)	HM-25 (X0)	HM-25 (X0)			
Minimum distances (mm)	X	100	100	150		
	Y	up to the pavement level				
	Z	100	100	150		

Installation minimal conditions. For more details, see installation instructions. It is the customer's responsibility to make sure that installation instructions are compatible with the type of soil.

# SELF ASPHALT

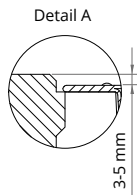
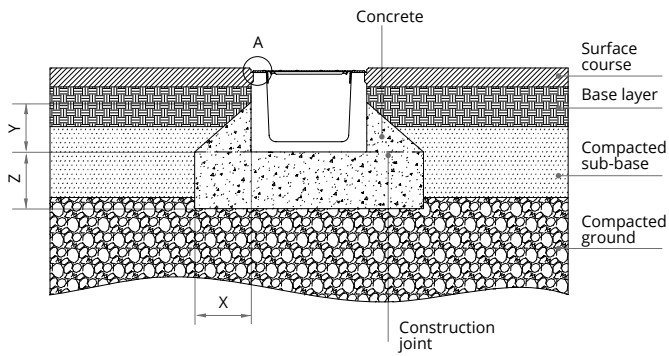

## A15 - B125 - C250

Load class EN 1433 Standard	A15	B125	C250	D400	E600	F900
Type of concrete EN 206-1 Standard	HM-25 (X0)	HM-25 (X0)	HM-25 (X0)			
Minimum distances (mm)	X	100	100	150		
	Y	100*	100*	100*		
	Z	100	100	150		

\* In case of an incorrect compaction of the soil, the concrete embracement must be made up to the pavement level.

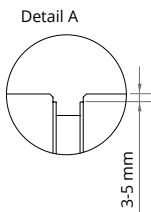
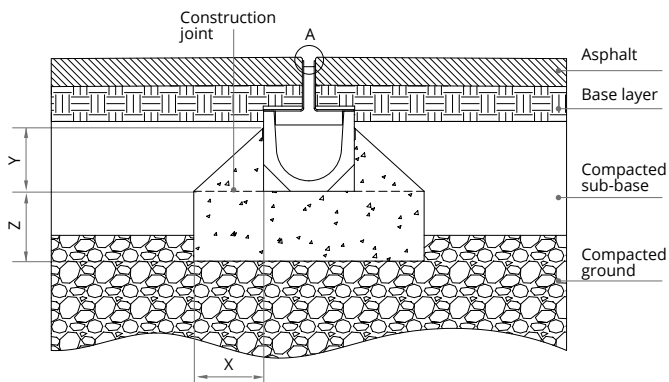

## A15 - B125 - C250 with slot grating

Load class EN 1433 Standard	A15	B125	C250	D400	E600	F900
Type of concrete EN 206-1 Standard	HM-25 (X0)	HM-25 (X0)	HM-25 (X0)			
Minimum distances (mm)	X	100	100	150		
	Y	100*	100*	100*		
	Z	100	100	150		

\* In case of an incorrect compaction of the soil, the concrete embracement must be made up to the pavement level.

# SELF CONCRETE

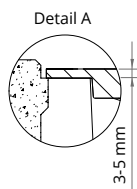
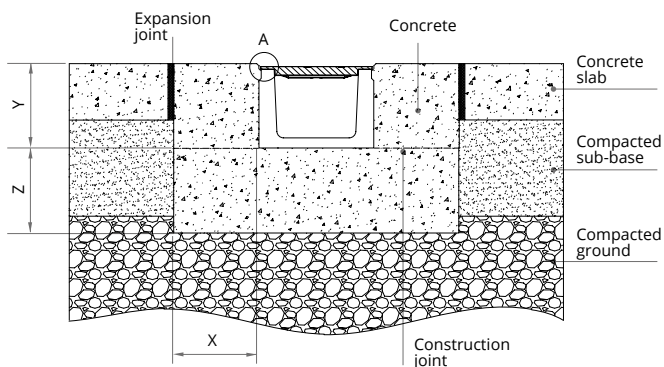

## A15 - B125 - C250

Load class EN 1433 Standard	A15	B125	C250	D400	E600	F900
Type of concrete EN 206-1 Standard	HM-25 (X0)	HM-25 (X0)	HM-25 (X0)			
Minimum distances (mm)	X	100	100	150		
	Y	channel height + grid + 3-5 mm				
	Z	100	100	150		

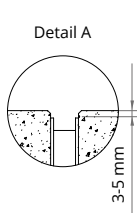
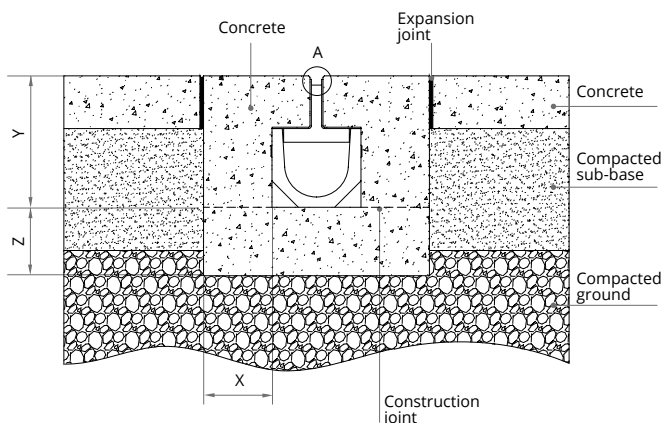

## A15 - B125 - C250 with slot grating

Load class EN 1433 Standard	A15	B125	C250	D400	E600	F900
Type of concrete EN 206-1 Standard	HM-25 (X0)	HM-25 (X0)	HM-25 (X0)			
Minimum distances (mm)	X	100	100	150		
	Y	channel height + grid + 3-5 mm				
	Z	100	100	150		

Installation minimal conditions. For more details, see installation instructions.

It is the customer's responsibility to make sure that installation instructions are compatible with the type of soil.

## SELFK PAVER

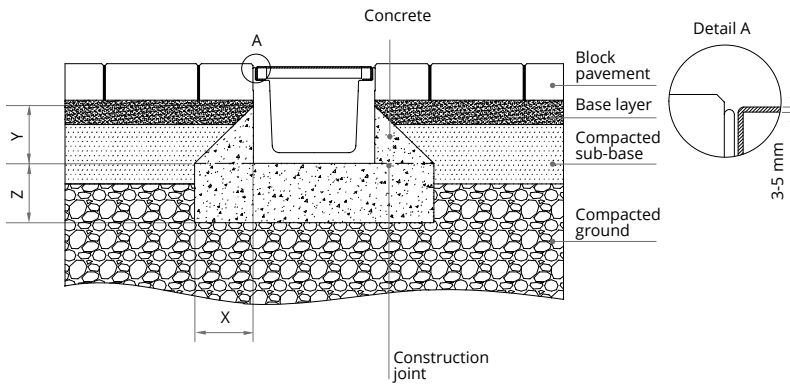

### A15 - B125 - C250

Load class EN 1433 Standard	A15	B125	C250	D400	E600	F900
Type of concrete EN 206-1 Standard	HM-25 (X0)	HM-25 (X0)	HM-25 (X0)			
Minimum distances (mm)	X	100	100	150		
	Y	100*	100*	100*		
	Z	100	100	150		

\* In case of an incorrect compactation of the soil, the concrete embracement must be made up to the pavement level.

## SELFK PAVER ONTO A LOAD-BEARING SLAB

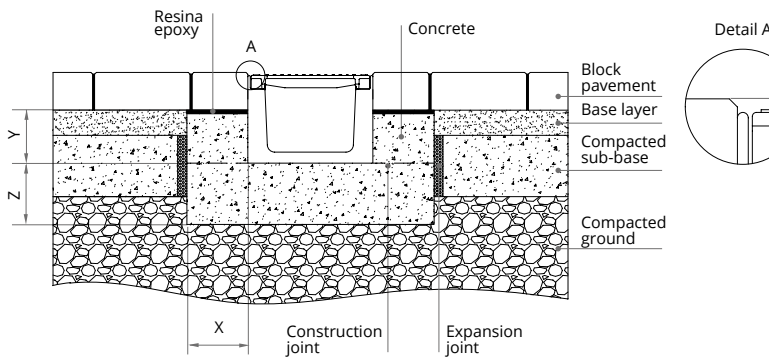

### A15 - B125 - C250

Load class EN 1433 Standard	A15	B125	C250	D400	E600	F900
Type of concrete EN 206-1 Standard	HM-25 (X0)	HM-25 (X0)	HM-25 (X0)			
Minimum distances (mm)	X	100	100	150		
	Y	up to the pavement level				
	Z	100	100	150		

## SELFK ASPHALT

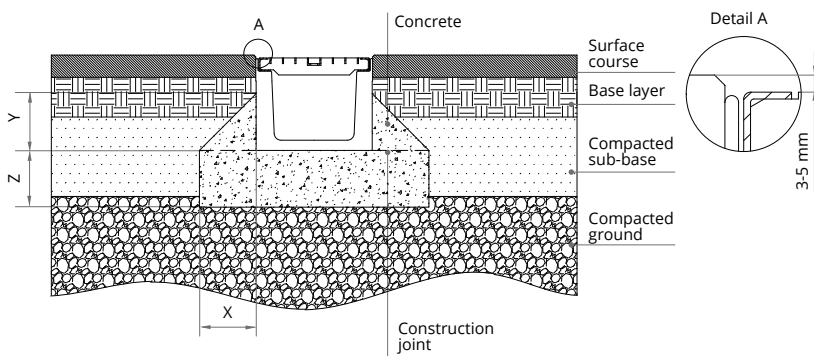

### A15 - B125 - C250

Load class EN 1433 Standard	A15	B125	C250	D400	E600	F900
Type of concrete EN 206-1 Standard	HM-25 (X0)	HM-25 (X0)	HM-25 (X0)			
Minimum distances (mm)	X	100	100	150		
	Y	100 *	100 *	100 *		
	Z	100	100	150		

\* In case of an incorrect compactation of the soil, the concrete embracement must be made up to the pavement level.

## SELFK CONCRETE

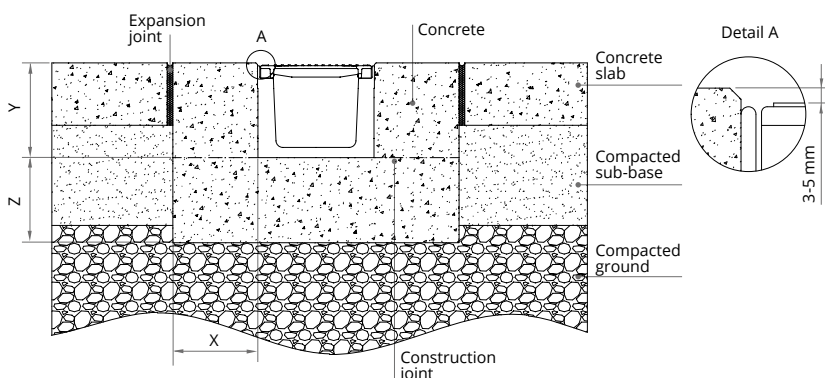

### A15 - B125 - C250

Load class EN 1433 Standard	A15	B125	C250	D400	E600	F900
Type of concrete EN 206-1 Standard	HM-25 (X0)	HM-25 (X0)	HM-25 (X0)			
Minimum distances (mm)	X	100	100	150		
	Y	channel height + grid + 3-5 mm				
	Z	100	100	150		

Installation minimal conditions. For more details, see installation instructions. It is the customer's responsibility to make sure that installation instructions are compatible with the type of soil.

# MINI System

MINIKIT | M100 | M100K | M100V | M150 | M150K | M200 | M200K | M300K

## MINI PAVER

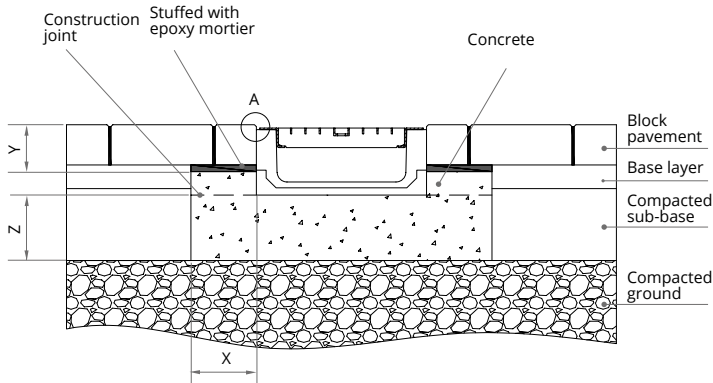

Detail A

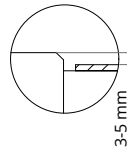

### A15 - B125 - C250

Load class EN 1433 Standard	A15	B125	C250	D400	E600	F900
Type of concrete EN 206-1 Standard	HM-25 (X0)	HM-25 (X0)	HM-25 (X0)			
Minimum distances (mm)	X	100	100	150		
	Y	up to the pavement level				
	Z	100	100	150		

## MINI ASPHALT

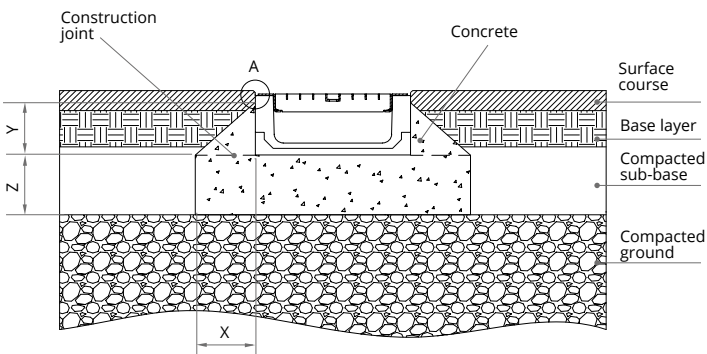

Detail A

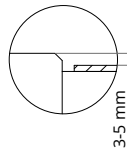

### A15 - B125 - C250

Load class EN 1433 Standard	A15	B125	C250	D400	E600	F900
Type of concrete EN 206-1 Standard	HM-25 (X0)	HM-25 (X0)	HM-25 (X0)			
Minimum distances (mm)	X	100	100	150		
	Y	100*	100*	100*		
	Z	100	100	150		

\* In case of an incorrect compaction of the soil, the concrete embracement must be made up to the pavement level.

## MINI CONCRETE

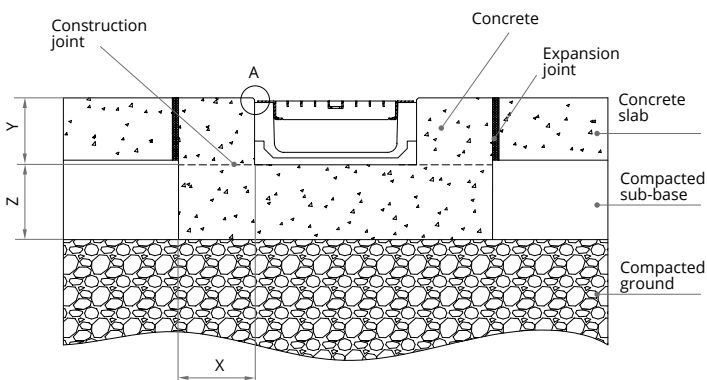

Detail A

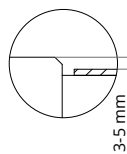

### A15 - B125 - C250

Load class EN 1433 Standard	A15	B125	C250	D400	E600	F900
Type of concrete EN 206-1 Standard	HM-25 (X0)	HM-25 (X0)	HM-25 (X0)			
Minimum distances (mm)	X	100	100	150		
	Y	channel height + grid + 3-5 mm				
	Z	100	100	150		

Installation minimal conditions. For more details, see installation instructions.

It is the customer's responsibility to make sure that installation instructions are compatible with the type of soil.

# URBAN System

U100 | U150 | U200 | U250  
 U100K | U150K | U200K | U300K

## URBAN PAVER

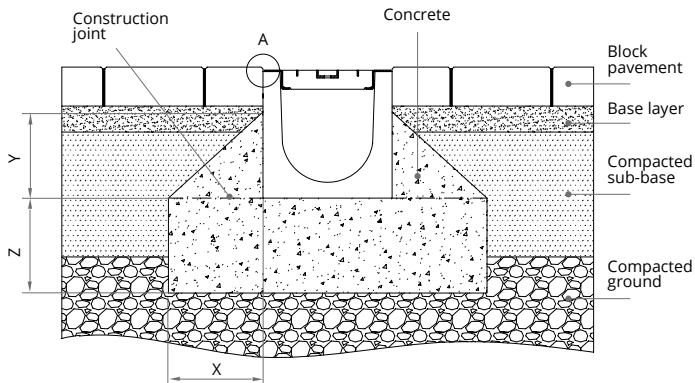

### A15 - B125 - C250

Load class EN 1433 Standard	A15	B125	C250	D400	E600	F900
Type of concrete EN 206-1 Standard	HM-25 (X0)	HM-25 (X0)	HM-25 (X0)			
Minimum distances (mm)	X	100	100	150		
	Y	above the arcs*				
	Z	100	100	150		

\* In case of an incorrect compaction of the soil, the concrete embracement must be made up to the pavement level.

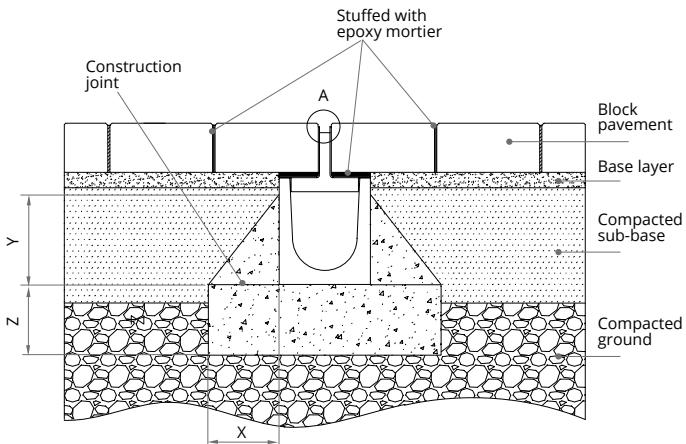

### A15 - B125 - C250 with slot grating

Load class EN 1433 Standard	A15	B125	C250	D400	E600	F900
Type of concrete EN 206-1 Standard	HM-25 (X0)	HM-25 (X0)	HM-25 (X0)			
Minimum distances (mm)	X	100	100	150		
	Y	above the arcs*				
	Z	100	100	150		

\* In case of an incorrect compaction of the soil, the concrete embracement must be made up to the pavement level.

## URBAN PAVER ONTO A LOAD-BEARING SLAB

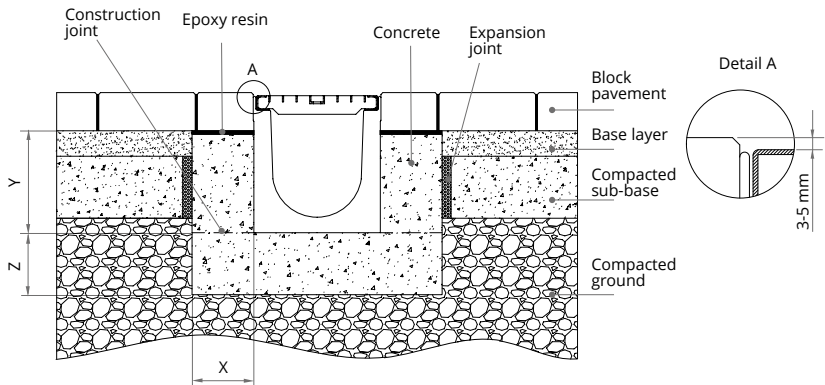

### A15 - B125 - C250

Load class EN 1433 Standard	A15	B125	C250	D400	E600	F900
Type of concrete EN 206-1 Standard	HM-25 (X0)	HM-25 (X0)	HM-25 (X0)			
Minimum distances (mm)	X	100	100	150		
	Y	up to the pavement level				
	Z	100	100	150		

Installation minimal conditions. For more details, see installation instructions. It is the customer's responsibility to make sure that installation instructions are compatible with the type of soil.



## URBAN ASPHALT

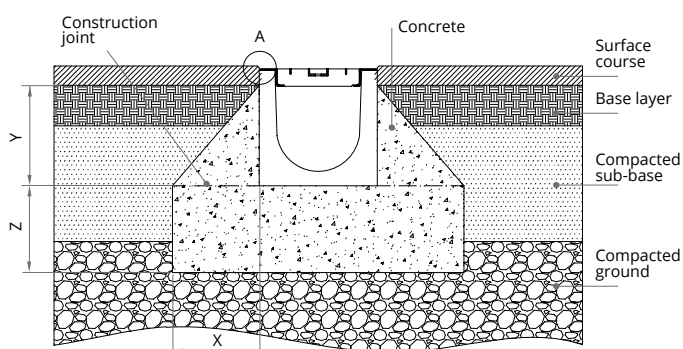

### A15 - B125 - C250

Load class EN 1433 Standard	A15	B125	C250	D400	E600	F900
Type of concrete EN 206-1 Standard	HM-25 (X0)	HM-25 (X0)	HM-25 (X0)			
Minimum distances (mm)	X	100	100	150		
	Y	above the arcs*				
	Z	100	100	150		

\* In case of an incorrect compaction of the soil, the concrete embracement must be made up to the pavement level.

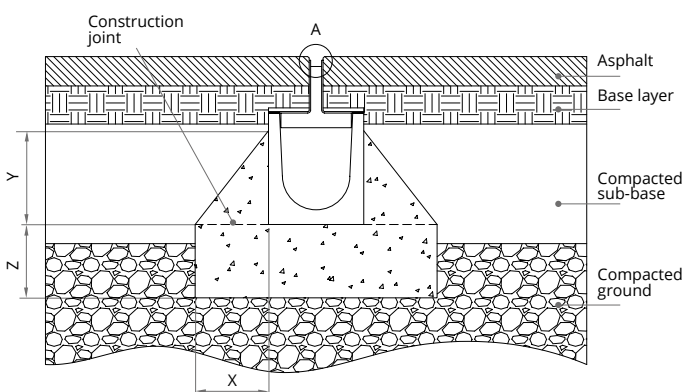

### A15 - B125 - C250 with slot grating

Load class EN 1433 Standard	A15	B125	C250	D400	E600	F900
Type of concrete EN 206-1 Standard	HM-25 (X0)	HM-25 (X0)	HM-25 (X0)			
Minimum distances (mm)	X	100	100	150		
	Y	above the arcs*				
	Z	100	100	150		

\* In case of an incorrect compaction of the soil, the concrete embracement must be made up to the pavement level.

## URBAN CONCRETE

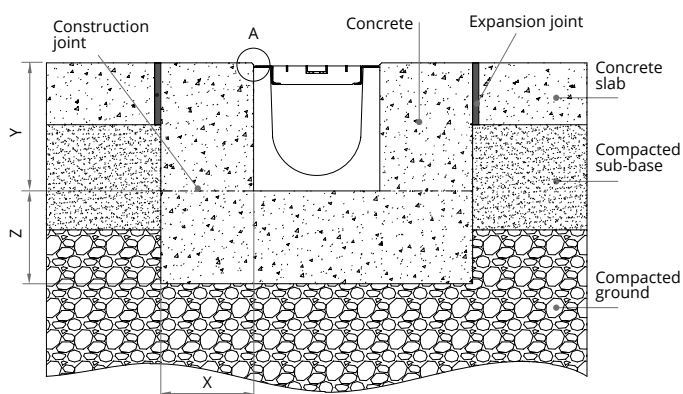

### A15 - B125 - C250

Load class EN 1433 Standard	A15	B125	C250	D400	E600	F900
Type of concrete EN 206-1 Standard	HM-25 (X0)	HM-25 (X0)	HM-25 (X0)			
Minimum distances (mm)	X	100	100	150		
	Y	channel height + grid + 3-5 mm				
	Z	100	100	150		

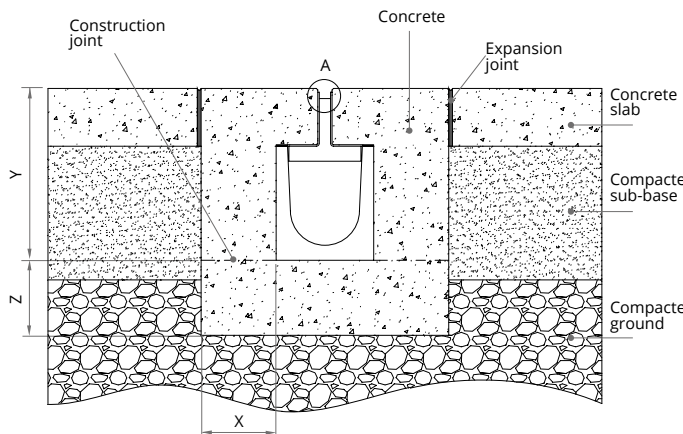

### A15 - B125 - C250 with slot grating

Load class EN 1433 Standard	A15	B125	C250	D400	E600	F900
Type of concrete EN 206-1 Standard	HM-25 (X0)	HM-25 (X0)	HM-25 (X0)			
Minimum distances (mm)	X	100	100	150		
	Y	channel height + grid + 3-5 mm				
	Z	100	100	150		

Installation minimal conditions. For more details, see installation instructions.

It is the customer's responsibility to make sure that installation instructions are compatible with the type of soil.

## URBANK PAVER

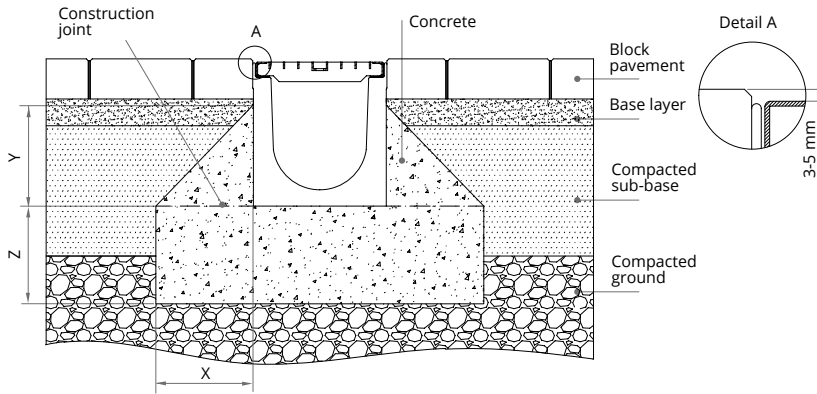

### A15 - B125 - C250

Load class EN 1433 Standard	A15	B125	C250	D400	E600	F900
Type of concrete EN 206-1 Standard	HM-25 (X0)	HM-25 (X0)	HM-25 (X0)			
Minimum distances (mm)	X	100	100	150		
	Y	above the arcs*				
	Z	100	100	150		

\* In case of an incorrect compaction of the soil, the concrete embracement must be made up to the pavement level.

## URBANK PAVER ONTO A LOAD-BEARING SLAB

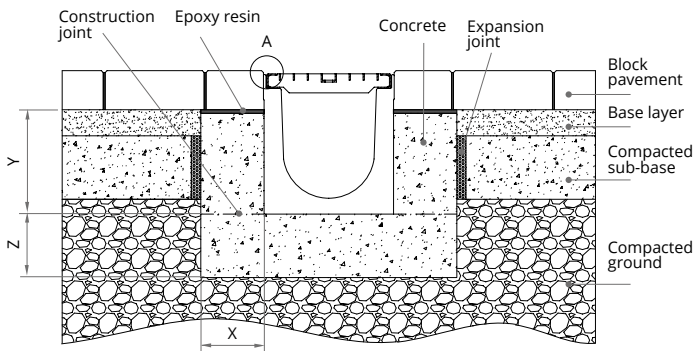

### A15 - B125 - C250

Load class EN 1433 Standard	A15	B125	C250	D400	E600	F900
Type of concrete EN 206-1 Standard	HM-25 (X0)	HM-25 (X0)	HM-25 (X0)			
Minimum distances (mm)	X	100	100	150		
	Y	up to the pavement level				
	Z	100	100	150		

## URBANK ASPHALT

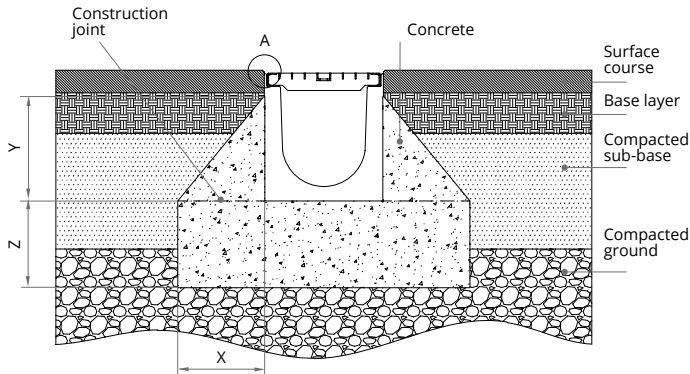

### A15 - B125 - C250

Load class EN 1433 Standard	A15	B125	C250	D400	E600	F900
Type of concrete EN 206-1 Standard	HM-25 (X0)	HM-25 (X0)	HM-25 (X0)			
Minimum distances (mm)	X	100	100	150		
	Y	above the arcs*				
	Z	100	100	150		

\* In case of an incorrect compaction of the soil, the concrete embracement must be made up to the pavement level.

## URBANK CONCRETE

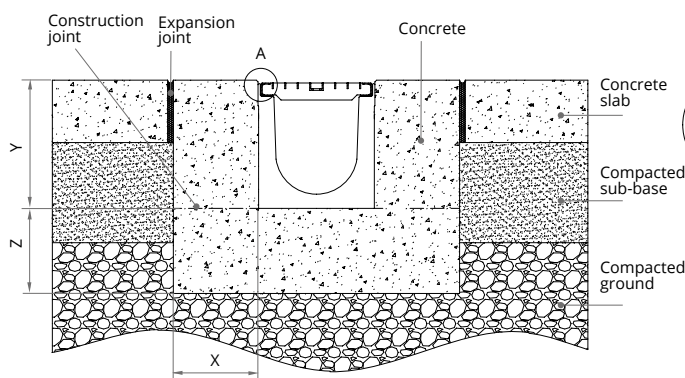

### A15 - B125 - C250

Load class EN 1433 Standard	A15	B125	C250	D400	E600	F900
Type of concrete EN 206-1 Standard	HM-25 (X0)	HM-25 (X0)	HM-25 (X0)			
Minimum distances (mm)	X	100	100	150		
	Y	channel height + grid + 3-5 mm				
	Z	100	100	150		

Installation minimal conditions. For more details, see installation instructions.  
It is the customer's responsibility to make sure that installation instructions are compatible with the type of soil.

# SPORT System

M100V | D100 | DPS100 | DP100.20 | SU100 | SU200  
 OCULTO10

## SPORT PAVER

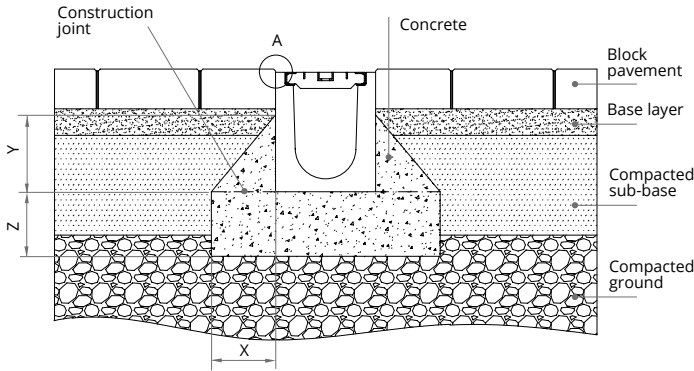

### A15 - B125 - C250

Load class EN 1433 Standard	A15	B125	C250	D400	E600	F900
Type of concrete EN 206-1 Standard	HM-25 (X0)	HM-25 (X0)	HM-25 (X0)			
Minimum distances (mm)	X	100	100	150		
	Y	100 *	100 *	100 *		
	Z	100	100	150		

\* In case of an incorrect compaction of the soil, the concrete embracement must be made up to the pavement level.

## SPORT PAVER ONTO A LOAD-BEARING SLAB

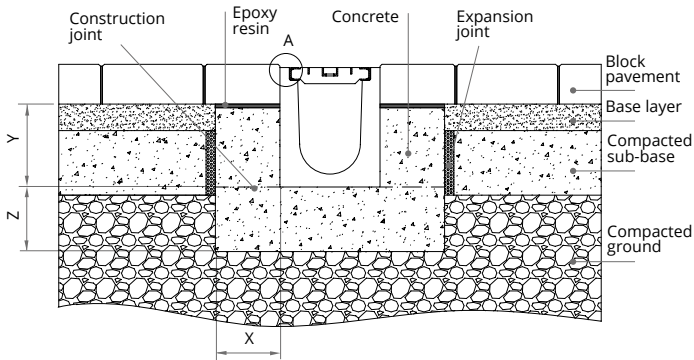

### A15 - B125 - C250

Load class EN 1433 Standard	A15	B125	C250	D400	E600	F900
Type of concrete EN 206-1 Standard	HM-25 (X0)	HM-25 (X0)	HM-25 (X0)			
Minimum distances (mm)	X	100	100	150		
	Y	up to the pavement level				
	Z	100	100	150		

## SPORT ASPHALT

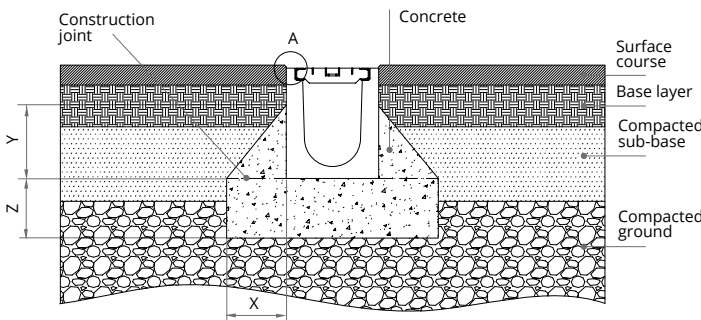

### A15 - B125 - C250

Load class EN 1433 Standard	A15	B125	C250	D400	E600	F900
Type of concrete EN 206-1 Standard	HM-25 (X0)	HM-25 (X0)	HM-25 (X0)			
Minimum distances (mm)	X	100	100	150		
	Y	100 *	100 *	100 *		
	Z	100	100	150		

\* In case of an incorrect compaction of the soil, the concrete embracement must be made up to the pavement level.

## SPORT CONCRETE

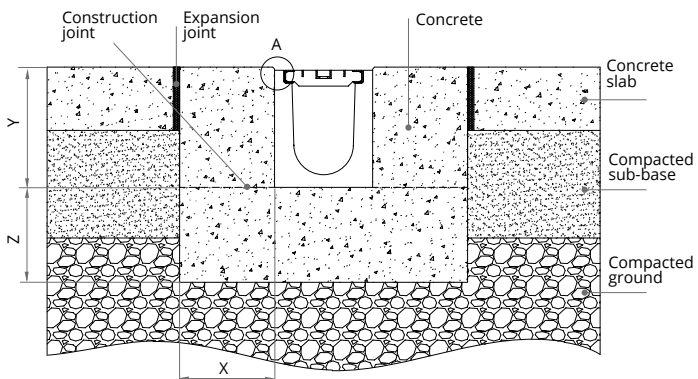

### A15 - B125 - C250

Load class EN 1433 Standard	A15	B125	C250	D400	E600	F900
Type of concrete EN 206-1 Standard	HM-25 (X0)	HM-25 (X0)	HM-25 (X0)			
Minimum distances (mm)	X	100	100	150		
	Y	channel height + grid + 3-5 mm				
	Z	100	100	150		

## SPORT OCULTO CONCRETE

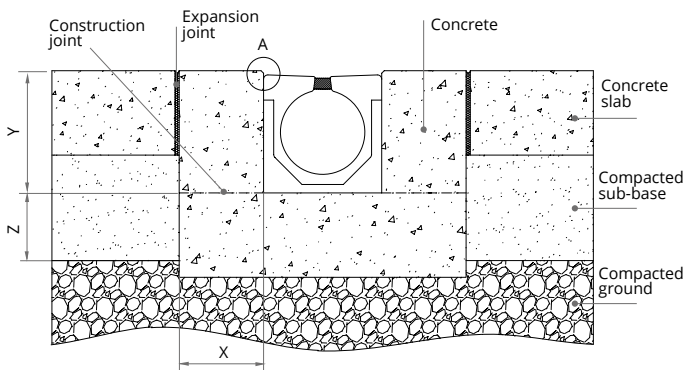

### A15

Load class EN 1433 Standard	A15	B125	C250	D400	E600	F900
Type of concrete EN 206-1 Standard	HM-25 (X0)					
Minimum distances (mm)	X	100				
	Y	channel height + grid + 3-5 mm				
	Z	100				

## SPORT OCULTO SYNTHETIC PAVEMENT

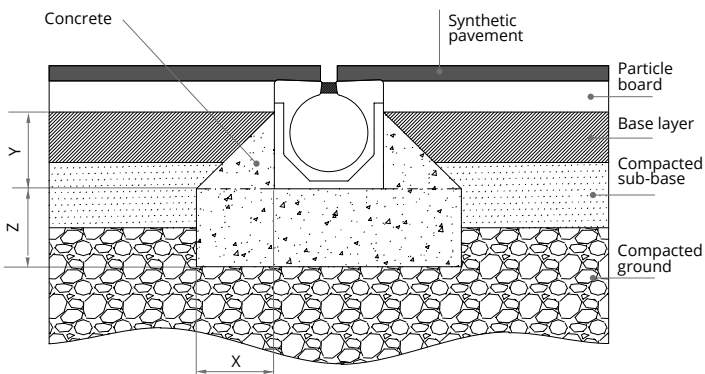

### A15

Load class EN 1433 Standard	A15	B125	C250	D400	E600	F900
Type of concrete EN 206-1 Standard	HM-25 (X0)					
Minimum distances (mm)	X	100				
	Y	100 *				
	Z	100				

\* In case of an incorrect compaction of the soil, the concrete embracement must be made up to the pavement level.

# HYDRO System

HYDROKIT | HYDROMINI | HYDRO  
 HYDROMINIPLUS | HYDROPLUS  
 HYDRO250  
 HYDRO250PLUS

## HYDRO PAVER

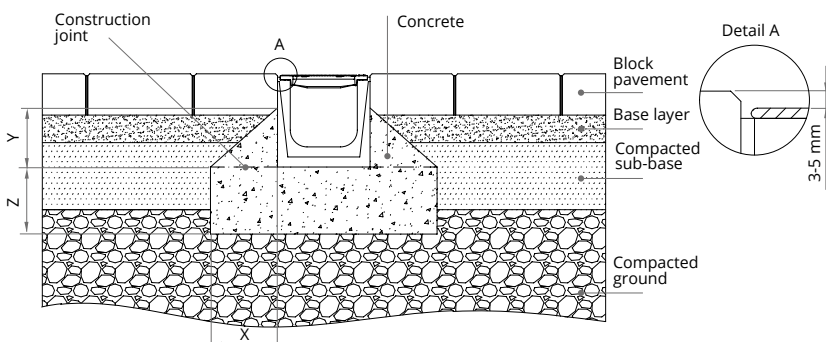

### A15 - B125 - C250

Load class EN 1433 Standard	A15	B125	C250	D400	E600	F900
Type of concrete EN 206-1 Standard	HM-25 (X0)	HM-25 (X0)	HM-25 (X0)			
Minimum distances (mm)	X	100	100	150		
	Y	100 *	100 *	100 *		
	Z	100	100	150		

\* In case of an incorrect compaction of the soil, the concrete embracement must be made up to the pavement level.

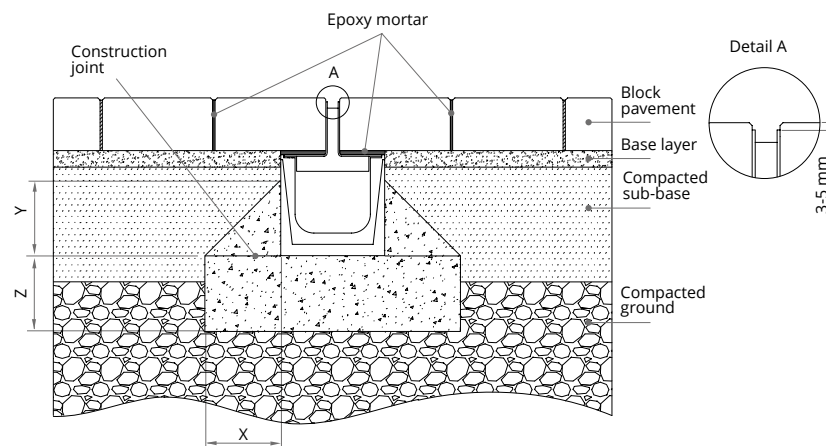

### A15 - B125 - C250 with slot grating

Load class EN 1433 Standard	A15	B125	C250	D400	E600	F900
Type of concrete EN 206-1 Standard	HM-25 (X0)	HM-25 (X0)	HM-25 (X0)			
Minimum distances (mm)	X	100	100	150		
	Y	100 *	100 *	100 *		
	Z	100	100	150		

\* In case of an incorrect compaction of the soil, the concrete embracement must be made up to the pavement level.

## HYDRO ASPHALT

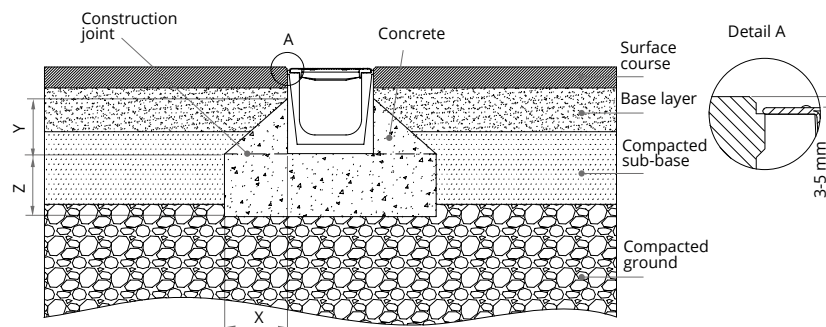

### A15 - B125 - C250

Load class EN 1433 Standard	A15	B125	C250	D400	E600	F900
Type of concrete EN 206-1 Standard	HM-25 (X0)	HM-25 (X0)	HM-25 (X0)			
Minimum distances (mm)	X	100	100	150		
	Y	100 *	100 *	100 *		
	Z	100	100	150		

\* In case of an incorrect compaction of the soil, the concrete embracement must be made up to the pavement level.

Installation minimal conditions. For more details, see installation instructions.

It is the customer's responsibility to make sure that installation instructions are compatible with the type of soil.

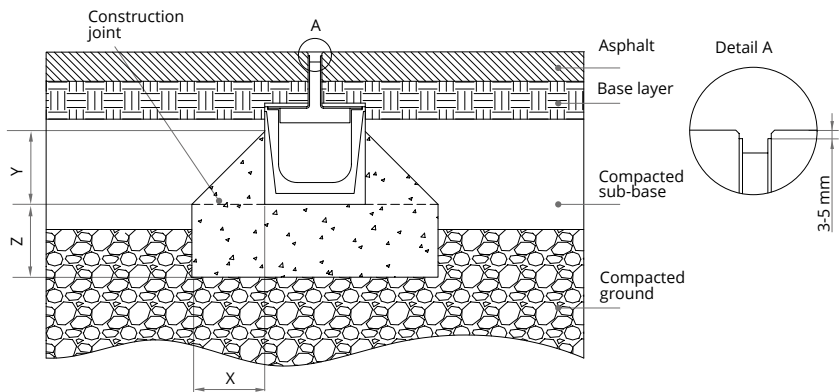

**A15 - B125 - C250 with slot grating**

Load class EN 1433 Standard	A15	B125	C250	D400	E600	F900
Type of concrete EN 206-1 Standard	HM-25 (X0)	HM-25 (X0)	HM-25 (X0)			
Minimum distances (mm)	X	100	100	150		
	Y	100 *	100 *	100 *		
	Z	100	100	150		

\* In case of an incorrect compaction of the soil, the concrete embracement must be made up to the pavement level.

**HYDRO CONCRETE**

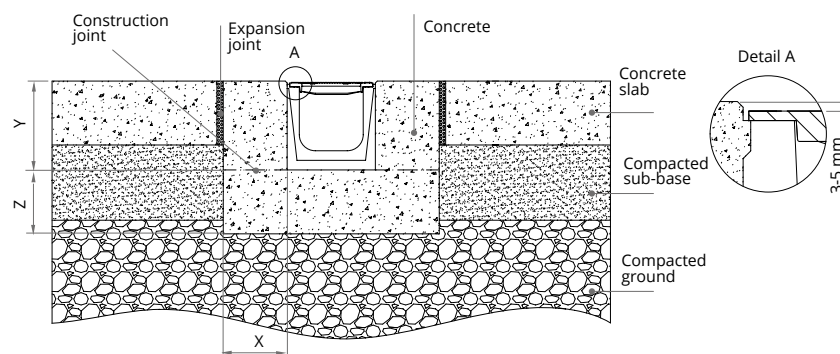

**A15 - B125 - C250**

Load class EN 1433 Standard	A15	B125	C250	D400	E600	F900
Type of concrete EN 206-1 Standard	HM-25 (X0)	HM-25 (X0)	HM-25 (X0)			
Minimum distances (mm)	X	100	100	150		
	Y	channel height + grid + 3-5 mm				
	Z	100	100	150		

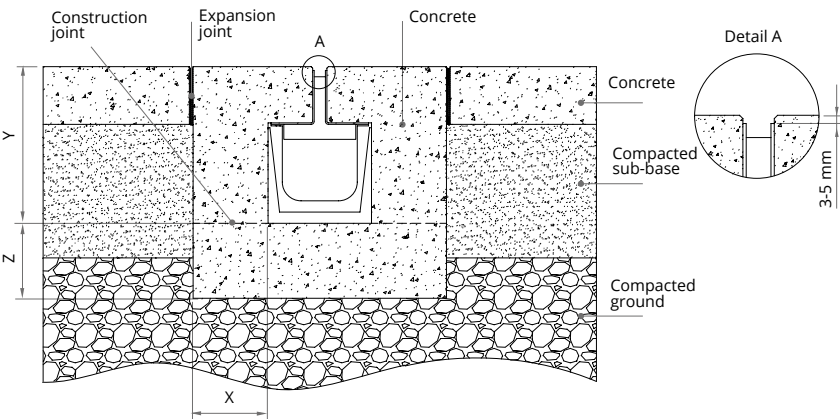

**A15 - B125 - C250 with slot grating**

Load class EN 1433 Standard	A15	B125	C250	D400	E600	F900
Type of concrete EN 206-1 Standard	HM-25 (X0)	HM-25 (X0)	HM-25 (X0)			
Minimum distances (mm)	X	100	100	150		
	Y	channel height + grid + 3-5 mm				
	Z	100	100	150		

**HYDROPLUS PAVER**

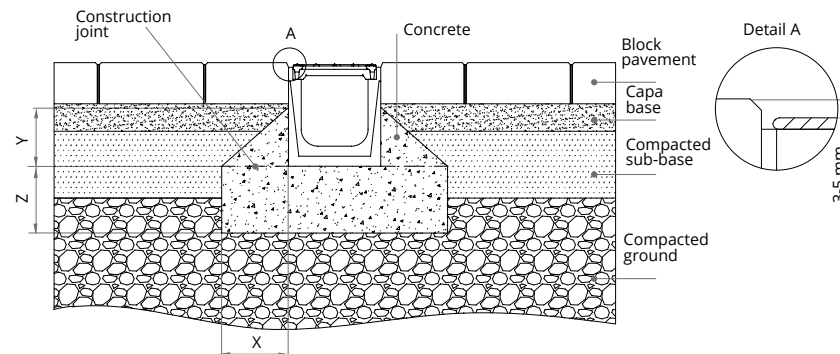

**A15 - B125 - C250**

Load class EN 1433 Standard	A15	B125	C250	D400	E600	F900
Type of concrete EN 206-1 Standard	HM-25 (X0)	HM-25 (X0)	HM-25 (X0)			
Minimum distances (mm)	X	100	100	150		
	Y	100 *	100 *	100 *		
	Z	100	100	150		

\* In case of an incorrect compaction of the soil, the concrete embracement must be made up to the pavement level.

Installation minimal conditions. For more details, see installation instructions. It is the customer's responsibility to make sure that installation instructions are compatible with the type of soil.

## HYDROPLUS ASPHALT

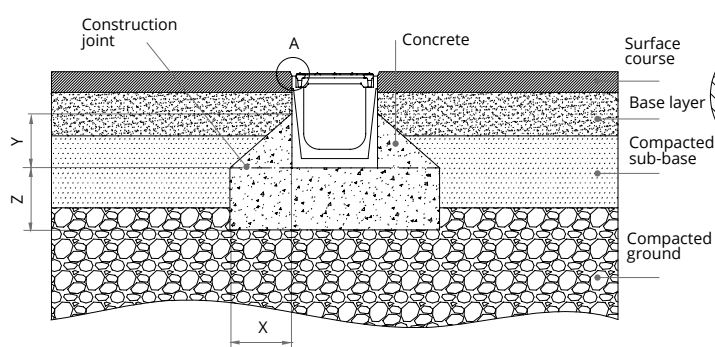

### A15 - B125 - C250

Load class EN 1433 Standard	A15	B125	C250	D400	E600	F900
Type of concrete EN 206-1 Standard	HM-25 (X0)	HM-25 (X0)	HM-25 (X0)			
Minimum distances (mm)	X	100	100	150		
	Y	100 *	100 *	100 *		
	Z	100	100	150		

\* In case of an incorrect compaction of the soil, the concrete embracement must be made up to the pavement level.

## HYDROPLUS CONCRETE

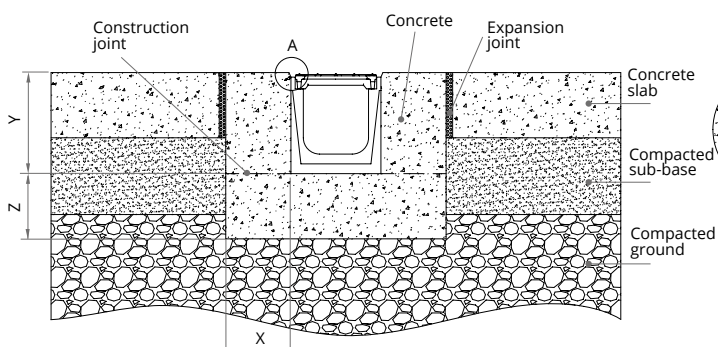

### A15 - B125 - C250

Load class EN 1433 Standard	A15	B125	C250	D400	E600	F900	
Type of concrete EN 206-1 Standard	HM-25 (X0)	HM-25 (X0)	HM-25 (X0)				
Minimum distances (mm)	X	100	100	150			
	Y	channel height + grid + 3-5 mm					
	Z	100	100	150			

## HYDRO250 PAVER

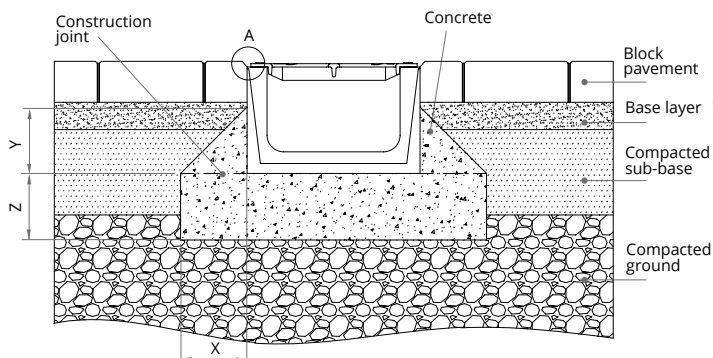

### A15 - B125 - C250

Load class EN 1433 Standard	A15	B125	C250	D400	E600	F900
Type of concrete EN 206-1 Standard	HM-25 (X0)	HM-25 (X0)	HM-25 (X0)			
Minimum distances (mm)	X	100	100	150		
	Y	100 *	100 *	100 *		
	Z	100	100	150		

\* In case of an incorrect compaction of the soil, the concrete embracement must be made up to the pavement level.

## HYDRO250 ASPHALT

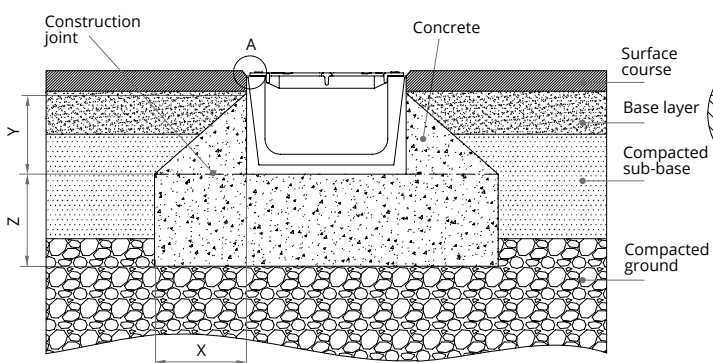

### A15 - B125 - C250

Load class EN 1433 Standard	A15	B125	C250	D400	E600	F900
Type of concrete EN 206-1 Standard	HM-25 (X0)	HM-25 (X0)	HM-25 (X0)			
Minimum distances (mm)	X	100	100	150		
	Y	100 *	100 *	100 *		
	Z	100	100	150		

\* In case of an incorrect compaction of the soil, the concrete embracement must be made up to the pavement level.

## HYDRO250 CONCRETE

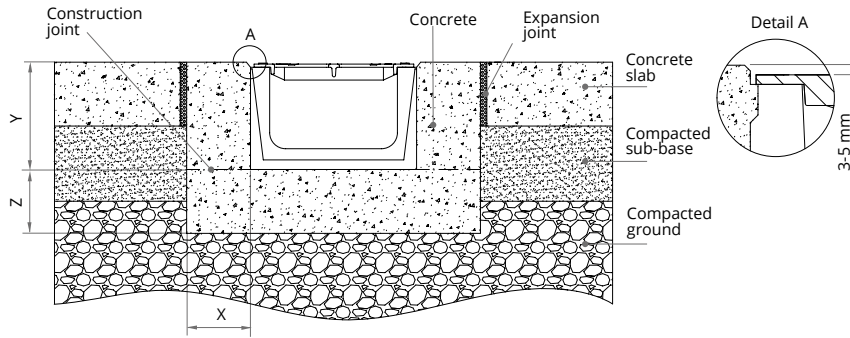

### A15 - B125 - C250

Load class EN 1433 Standard	A15	B125	C250	D400	E600	F900
Type of concrete EN 206-1 Standard	HM-25 (X0)	HM-25 (X0)	HM-25 (X0)			
Minimum distances (mm)	X	100	100	150		
	Y	channel height + grid + 3-5 mm				
	Z	100	100	150		

## HYDROPLUS250 PAVER

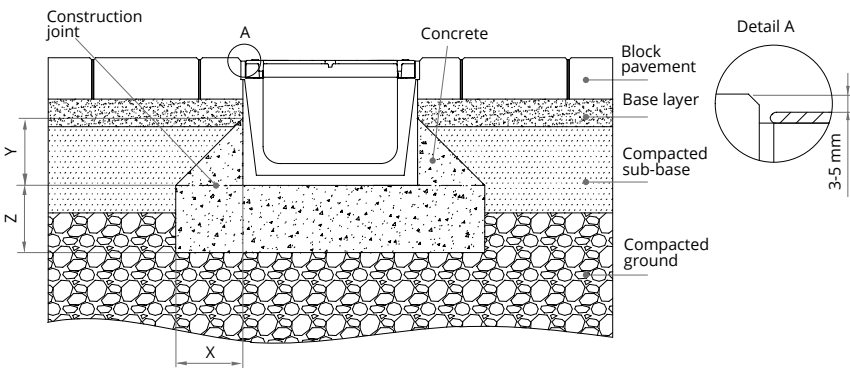

### A15 - B125 - C250

Load class EN 1433 Standard	A15	B125	C250	D400	E600	F900
Type of concrete EN 206-1 Standard	HM-25 (X0)	HM-25 (X0)	HM-25 (X0)			
Minimum distances (mm)	X	100	100	150		
	Y	100 *	100 *	100 *		
	Z	100	100	150		

\* In case of an incorrect compactation of the soil, the concrete embracement must be made up to the pavement level.

## HYDROPLUS250 ASPHALT

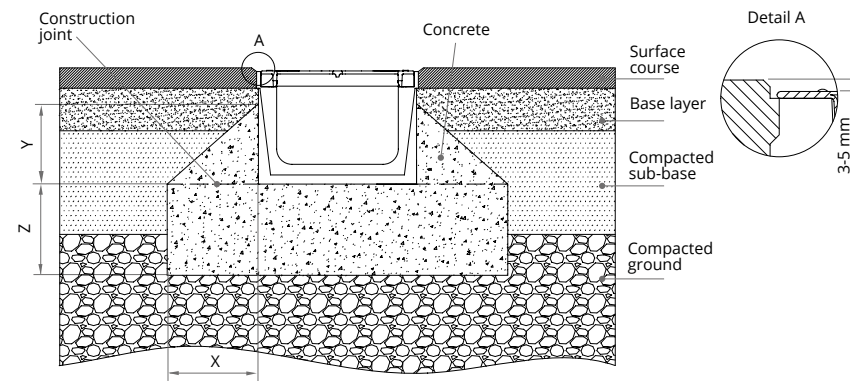

### A15 - B125 - C250

Load class EN 1433 Standard	A15	B125	C250	D400	E600	F900
Type of concrete EN 206-1 Standard	HM-25 (X0)	HM-25 (X0)	HM-25 (X0)			
Minimum distances (mm)	X	100	100	150		
	Y	100 *	100 *	100 *		
	Z	100	100	150		

\* In case of an incorrect compactation of the soil, the concrete embracement must be made up to the pavement level.

## HYDROPLUS250 CONCRETE

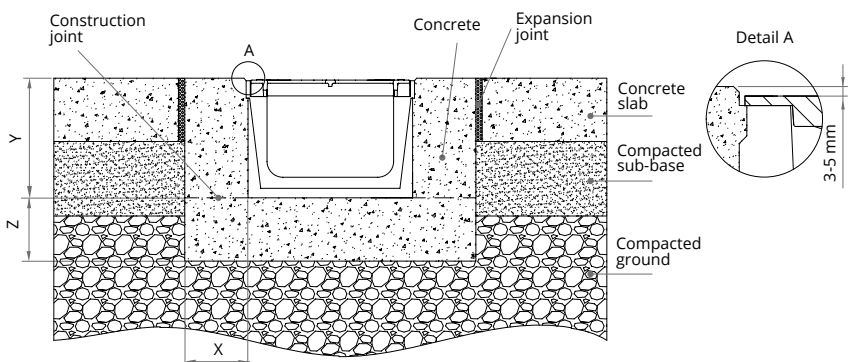

### A15 - B125 - C250

Load class EN 1433 Standard	A15	B125	C250	D400	E600	F900
Type of concrete EN 206-1 Standard	HM-25 (X0)	HM-25 (X0)	HM-25 (X0)			
Minimum distances (mm)	X	100	100	150		
	Y	channel height + grid + 3-5 mm				
	Z	100	100	150		

Installation minimal conditions. For more details, see installation instructions.  
It is the customer's responsibility to make sure that installation instructions are compatible with the type of soil.



# MULTIV+ System

MULTIV+100 | MULTIV+150 | MULTIV+200

## MULTIV+ PAVER

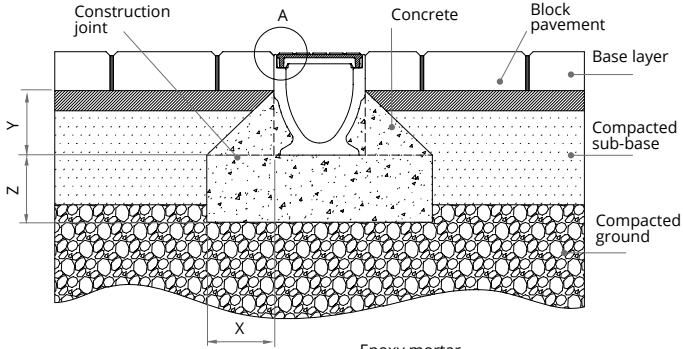

### A15 - B125 - C250

Load class EN 1433 Standard	A15	B125	C250	D400	E600	F900
Type of concrete EN 206-1 Standard	HM-25 (X0)	HM-25 (X0)	HM-25 (X0)			
Minimum distances (mm)	X	100	100	150		
	Y	above the arcs*				
	Z	100	100	150		

\* In case of an incorrect compaction of the soil, the concrete embracement must be made up to the pavement level.

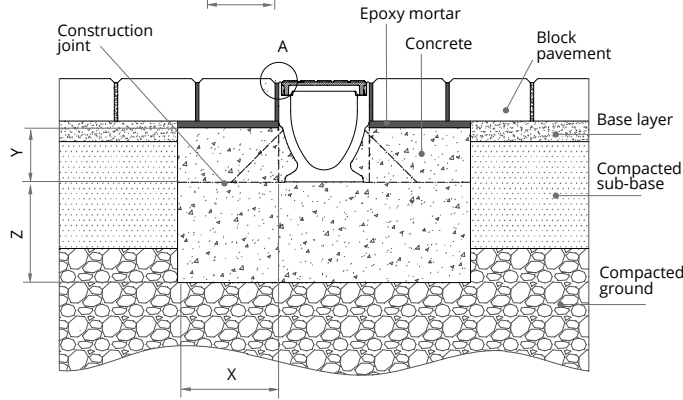

### D400

Load class EN 1433 Standard	A15	B125	C250	D400	E600	F900
Type of concrete EN 206-1 Standard				HM-25 (X0)		
Minimum distances (mm)	X			150		
	Y			up to the pavement level		
	Z			150		

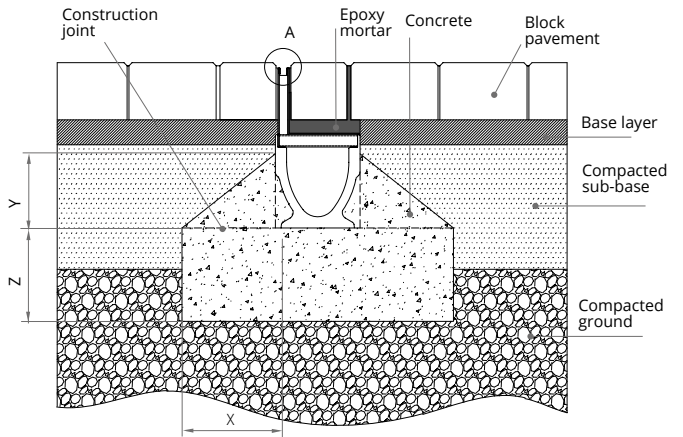

### A15 - B125 - C250 with slot grating

Load class EN 1433 Standard	A15	B125	C250	D400	E600	F900
Type of concrete EN 206-1 Standard	HM-25 (X0)	HM-25 (X0)	HM-25 (X0)			
Minimum distances (mm)	X	100	100	150		
	Y	above the arcs*				
	Z	100	100	150		

\* In case of an incorrect compaction of the soil, the concrete embracement must be made up to the pavement level.

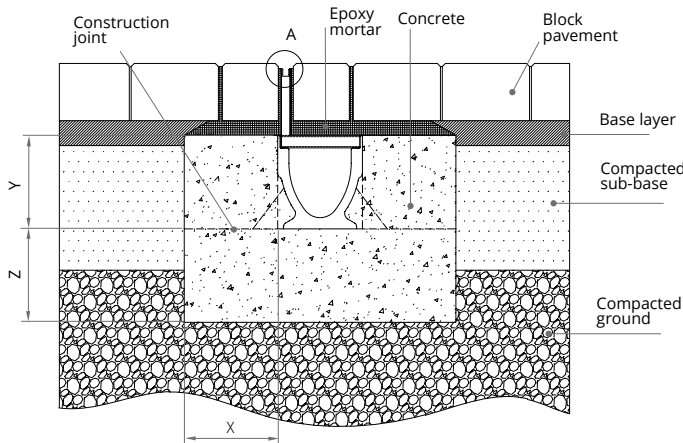

### D400 with slot grating

Load class EN 1433 Standard	A15	B125	C250	D400	E600	F900
Type of concrete EN 206-1 Standard				HM-25 (X0)		
Minimum distances (mm)	X			150		
	Y			up to the pavement level		
	Z			150		

Installation minimal conditions. For more details, see installation instructions.

It is the customer's responsibility to make sure that installation instructions are compatible with the type of soil.

# MULTIV+ PAVER ONTO A LOAD-BEARING SLAB

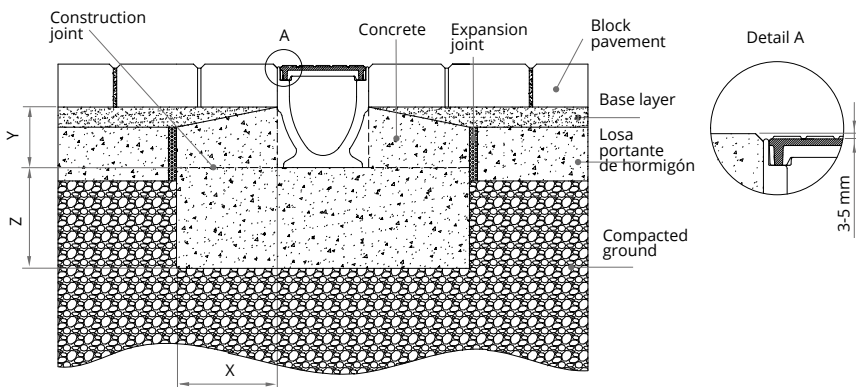

## A15 - B125 - C250

Load class EN 1433 Standard	A15	B125	C250	D400	E600	F900
Type of concrete EN 206-1 Standard	HM-25 (X0)	HM-25 (X0)	HM-25 (X0)			
Minimum distances (mm)	X	100	100	150		
	Y	up to the pavement level				
	Z	100	100	150		

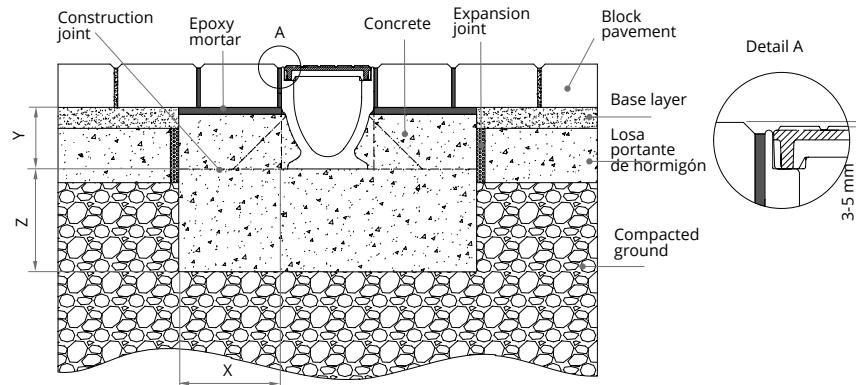

## D400

Load class EN 1433 Standard	A15	B125	C250	D400	E600	F900
Type of concrete EN 206-1 Standard				HM-25 (X0)		
Minimum distances (mm)	X			150		
	Y			up to the pavement level		
	Z			150		

# MULTIV+ ASPHALT

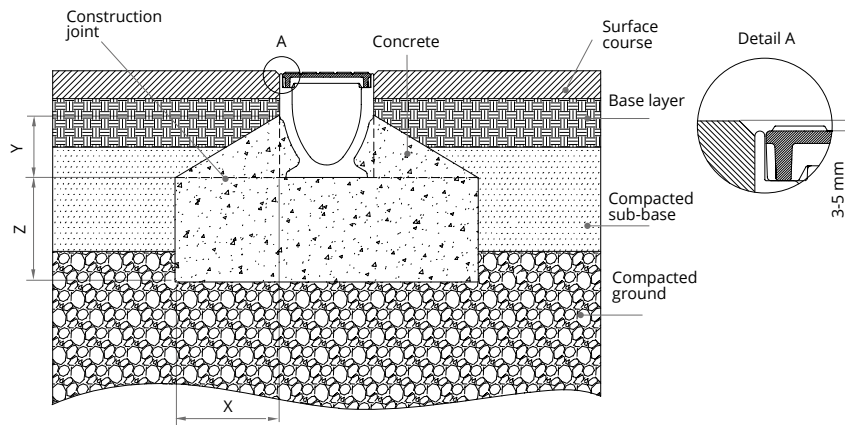

## A15 - B125 - C250

Load class EN 1433 Standard	A15	B125	C250	D400	E600	F900
Type of concrete EN 206-1 Standard	HM-25 (X0)	HM-25 (X0)	HM-25 (X0)			
Minimum distances (mm)	X	100	100	150		
	Y	above the arcs*				
	Z	100	100	150		

\* In case of an incorrect compaction of the soil, the concrete embracement must be made up to the pavement level.

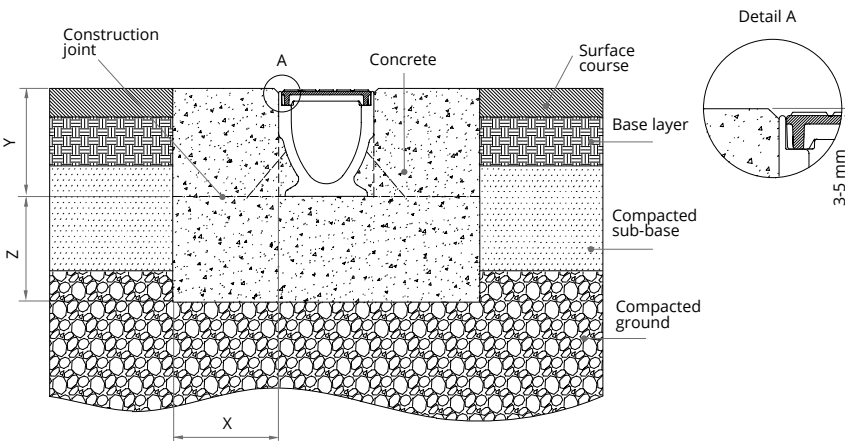

## D400

Load class EN 1433 Standard	A15	B125	C250	D400	E600	F900
Type of concrete EN 206-1 Standard				HM-25 (X0)		
Minimum distances (mm)	X			150		
	Y			channel height + grid + 3-5 mm		
	Z			150		

Installation minimal conditions. For more details, see installation instructions. It is the customer's responsibility to make sure that installation instructions are compatible with the type of soil.

## MULTIV+ ASPHALT

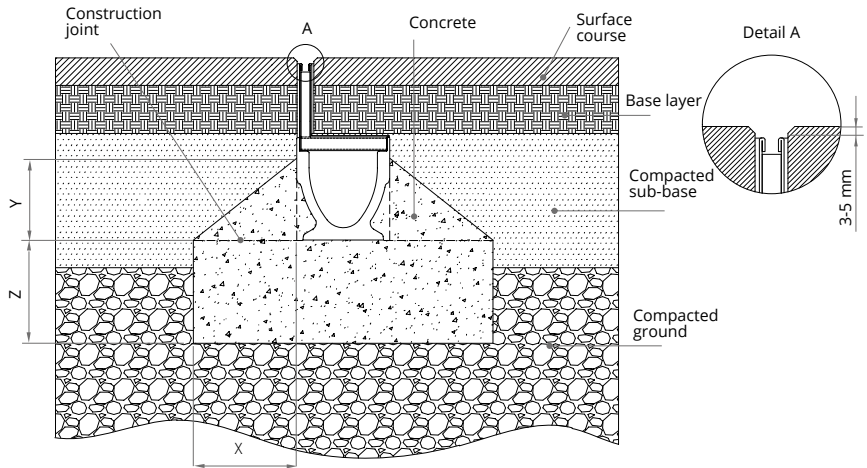

### A15 - B125 - C250 with slot grating

Load class EN 1433 Standard	A15	B125	C250	D400	E600	F900
Type of concrete EN 206-1 Standard	HM-25 (X0)	HM-25 (X0)	HM-25 (X0)			
Minimum distances (mm)	X	100	100	150		
	Y	above the arcs*				
	Z	100	100	150		

\* In case of an incorrect compaction of the soil, the concrete embracement must be made up to the pavement level.

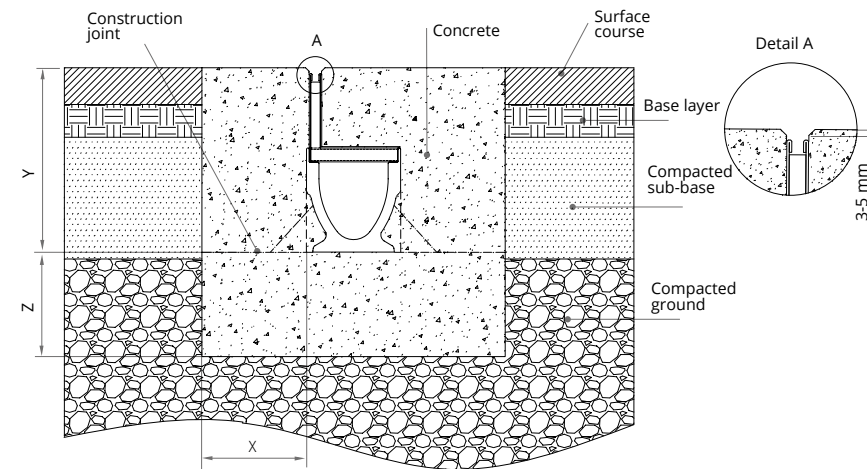

### D400 with slot grating

Load class EN 1433 Standard	A15	B125	C250	D400	E600	F900
Type of concrete EN 206-1 Standard				HM-25 (X0)		
Minimum distances (mm)	X			150		
	Y			channel height + grid + 3-5 mm		
	Z			150		

## MULTIV+ CONCRETE

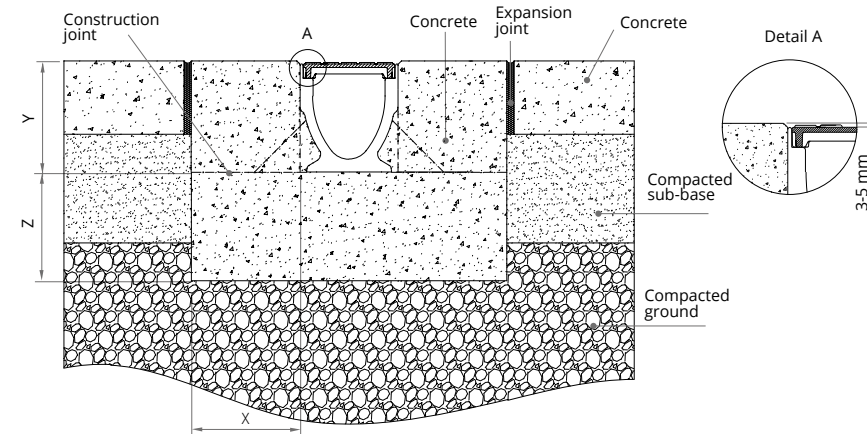

### A15 - B125 - C250 - D400

Load class EN 1433 Standard	A15	B125	C250	D400	E600	F900
Type of concrete EN 206-1 Standard	HM-25 (X0)	HM-25 (X0)	HM-25 (X0)	HM-25 (X0)		
Minimum distances (mm)	X	100	100	150	150	
	Y	channel height + grid + 3-5 mm				
	Z	100	100	150	150	

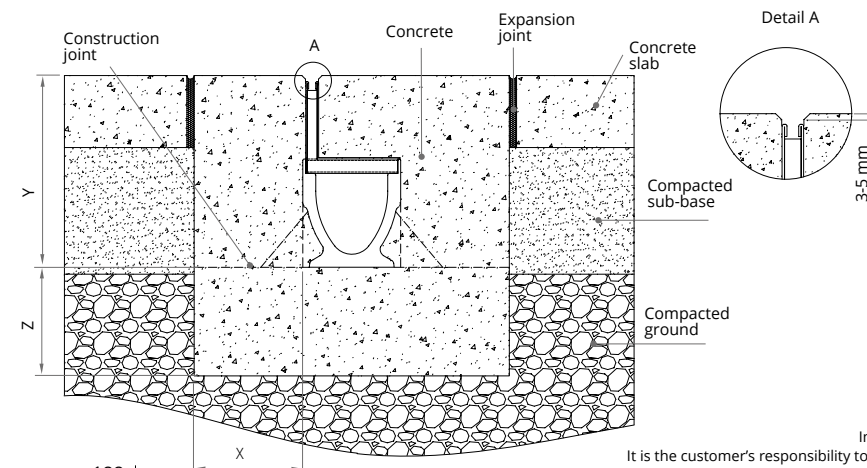

### A15 - B125 - C250 - D400 with slot grating

Load class EN 1433 Standard	A15	B125	C250	D400	E600	F900
Type of concrete EN 206-1 Standard	HM-25 (X0)	HM-25 (X0)	HM-25 (X0)	HM-25 (X0)		
Minimum distances (mm)	X	100	100	150	150	
	Y	channel height + grid + 3-5 mm				
	Z	100	100	150	150	

Installation minimal conditions. For more details, see installation instructions.

It is the customer's responsibility to make sure that installation instructions are compatible with the type of soil.

# CIVIL-S System

SM250F | SM250MF | SM350F | SM350MF | S200F | S200MF | S250F | S250MF  
 S300F | S300MF | S350F | S350MF

## CIVIL-S ASPHALT

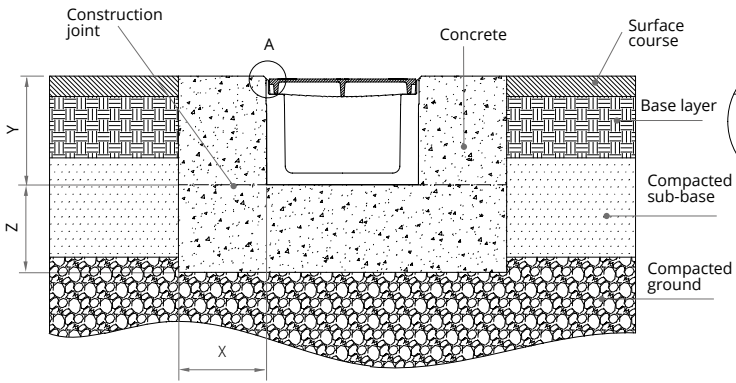

### D400 - E600 - F900

Load class EN 1433 Standard	A15	B125	C250	D400	E600	F900
Type of concrete EN 206-1 Standard				HM-25 (X0)	HM-25 (X0)	HM-25 (X0)
Minimum distances (mm)	X			150	200	200
	Y			channel height + grid + 3-5 mm		
	Z			150	200	200

## CIVIL-S CONCRETE

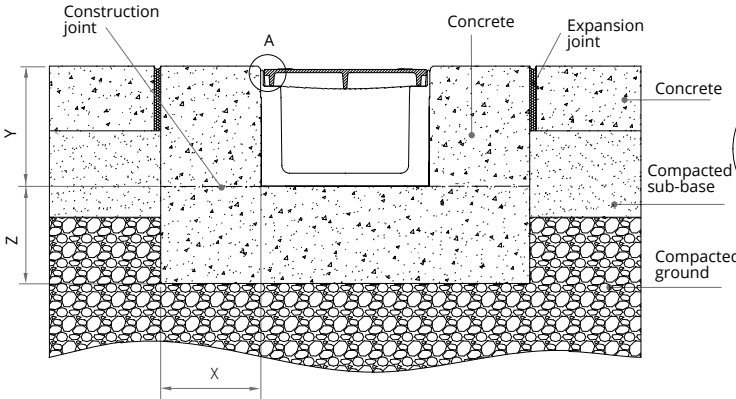

### D400 - E600 - F900

Load class EN 1433 Standard	A15	B125	C250	D400	E600	F900
Type of concrete EN 206-1 Standard				HM-25 (X0)	HM-25 (X0)	HM-25 (X0)
Minimum distances (mm)	X			150	200	200
	Y			channel height + grid + 3-5 mm		
	Z			150	200	200

Installation minimal conditions. For more details, see installation instructions. It is the customer's responsibility to make sure that installation instructions are compatible with the type of soil.

# CIVIL-F System

F100K | F100MF | F150K | F150MF | F200K | F200MF | F250K | F250MF  
 F300K | F300MF | F400K | F400MF

## F100 | F150 | F200 | F250 ASPHALT

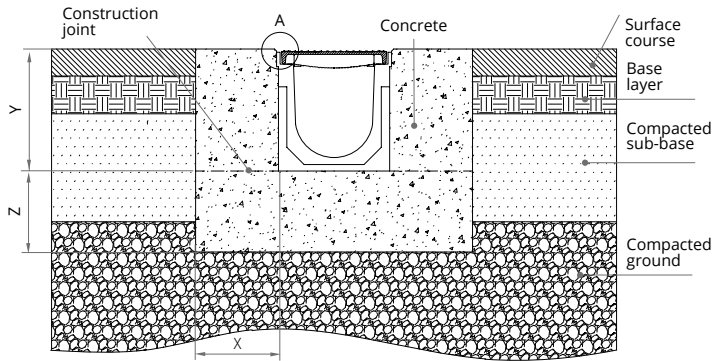

### D400 - E600 - F900 Longitudinal to the traffic direction

Load class EN 1433 Standard	A15	B125	C250	D400	E600	F900 *
Type of concrete EN 206-1 Standard				HM-25 (X0)	HM-25 (X0)	HM-25 (X0)
Minimum distances (mm)	X			150	200	200
	Y			channel height + grid + 3-5 mm		
	Z			150	200	200

\*Complies F900 load class without reinforcing wire mesh.

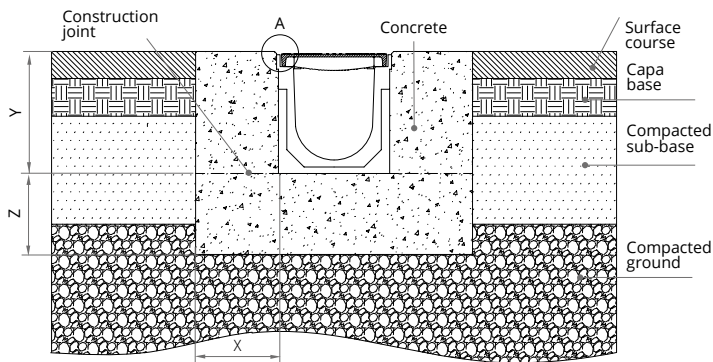

### D400 - E600 - F900 Transversal to the traffic direction

Load class EN 1433 Standard	A15	B125	C250	D400	E600	F900
Type of concrete EN 206-1 Standard				HM-25 (X0)	HM-25 (X0)	HM-25 (X0)
Minimum distances (mm)	X			200	200	consult
	Y			channel height + grid + 3-5 mm		
	Z			200	200	

For heavy transversal traffic use always KompaqDrain channels.

## F100 | F150 | F200 | F250 CONCRETE

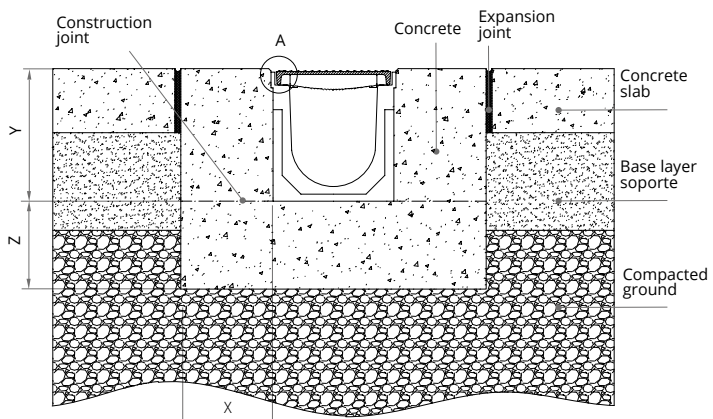

### D400 - E600 - F900 Longitudinal to the traffic direction

Load class EN 1433 Standard	A15	B125	C250	D400	E600	F900 *
Type of concrete EN 206-1 Standard				HM-25 (X0)	HM-25 (X0)	HM-25 (X0)
Minimum distances (mm)	X			150	200	200
	Y			channel height + grid + 3-5 mm		
	Z			150	200	200

\*Complies F900 load class without reinforcing wire mesh.

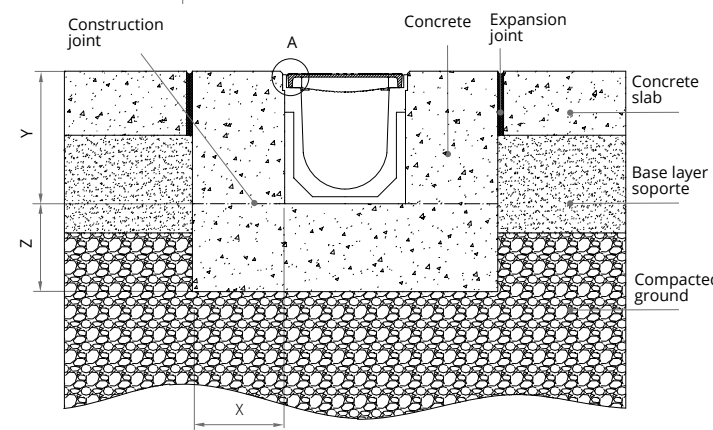

### D400 - E600 - F900 Transversal to the traffic direction

Load class EN 1433 Standard	A15	B125	C250	D400	E600	F900
Type of concrete EN 206-1 Standard				HM-25 (X0)	HM-25 (X0)	HM-25 (X0)
Minimum distances (mm)	X			200	200	consult
	Y			channel height + grid + 3-5 mm		
	Z			200	200	

For heavy transversal traffic use always KompaqDrain channels.

Installation minimal conditions. For more details, see installation instructions.

It is the customer's responsibility to make sure that installation instructions are compatible with the type of soil.

F300 | F400 ASPHALT

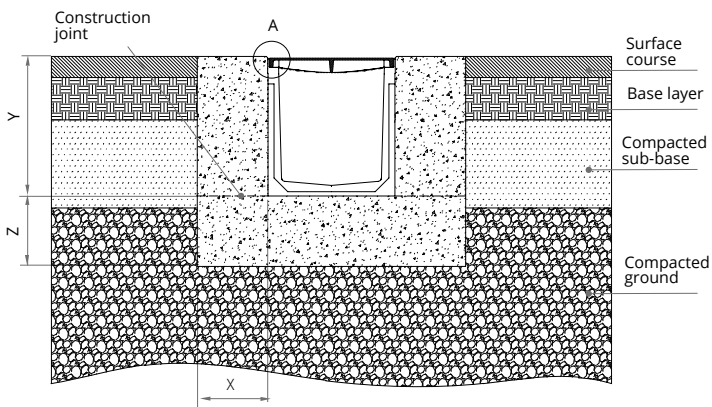

D400 - E600 - F900  
Longitudinal to the traffic direction

Load class EN 1433 Standard	A15	B125	C250	D400	E600	F900 *
Type of concrete EN 206-1 Standard				HM-25 (X0)	HM-25 (X0)	HM-25 (X0)
Minimum distances (mm)	X			200	200	200
	Y			channel height + grid + 3-5 mm		
	Z			200	200	200

\*Complies F900 load class without reinforcing wire mesh.

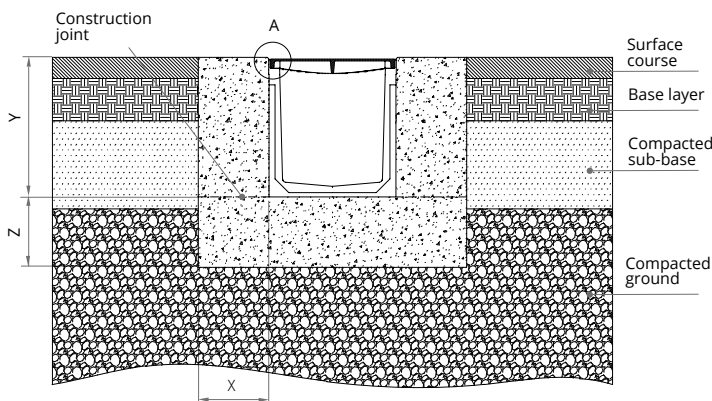

D400 - E600 - F900  
Transversal to the traffic direction

Load class EN 1433 Standard	A15	B125	C250	D400	E600	F900
Type of concrete EN 206-1 Standard				HM-25 (X0)	HM-25 (X0)	HM-25 (X0)
Minimum distances (mm)	X			200	200	consult
	Y			channel height + grid + 3-5 mm		
	Z			200	200	

For heavy transversal traffic use always KompaqDrain channels.

F300 | F400 CONCRETE

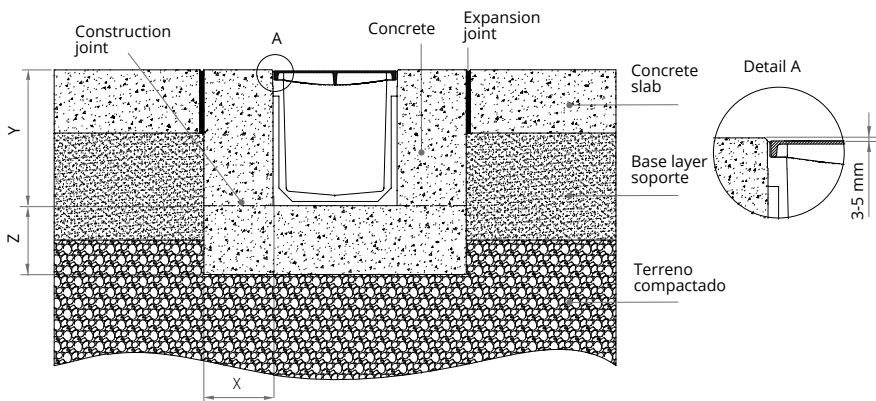

D400 - E600 - F900  
Longitudinal to the traffic direction

Load class EN 1433 Standard	A15	B125	C250	D400	E600	F900 *
Type of concrete EN 206-1 Standard				HM-25 (X0)	HM-25 (X0)	HM-25 (X0)
Minimum distances (mm)	X			200	200	200
	Y			channel height + grid + 3-5 mm		
	Z			200	200	200

\*Complies F900 load class without reinforcing wire mesh.

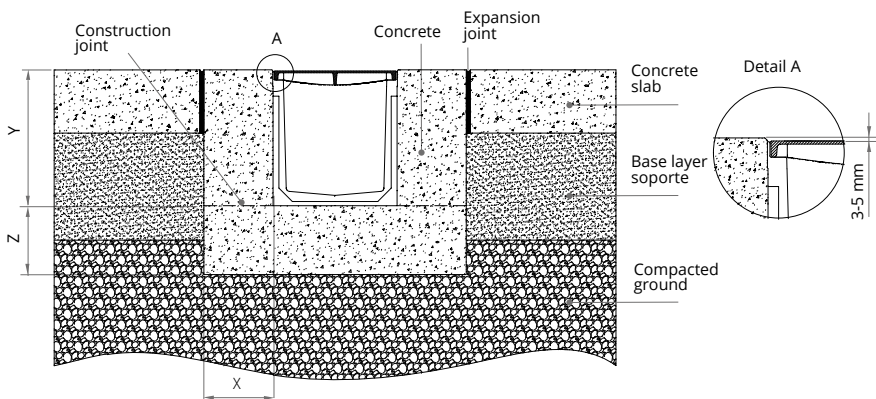

D400 - E600 - F900  
Transversal to the traffic direction

Load class EN 1433 Standard	A15	B125	C250	D400	E600	F900
Type of concrete EN 206-1 Standard				HM-25 (X0)	HM-25 (X0)	HM-25 (X0)
Minimum distances (mm)	X			200	200	consult
	Y			channel height + grid + 3-5 mm		
	Z			200	200	

For heavy transversal traffic use always KompaqDrain channels.

Installation minimal conditions. For more details, see installation instructions. It is the customer's responsibility to make sure that installation instructions are compatible with the type of soil.

# KOMPAQDRAIN System

**KVFDH100 | KVFDH150 | KVFD150 | KVFDH200 | KVFD200**  
**KVE150 | KVF150 | KVE200 | KVF200**

## KVFDH | KVFD PAVER

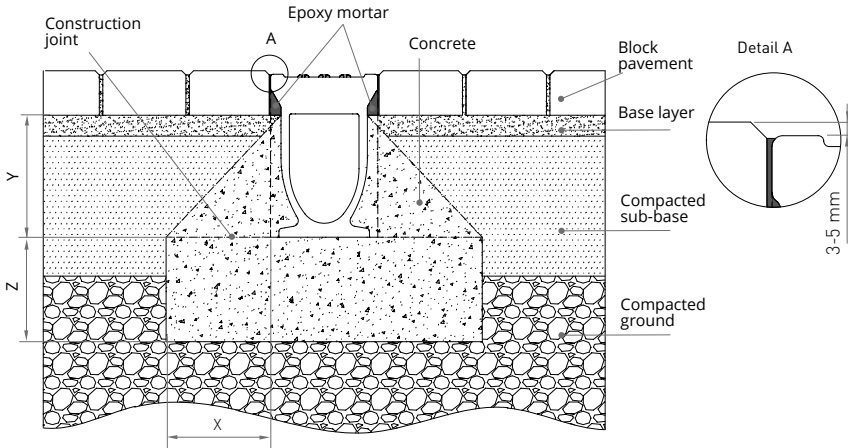

### A15 - B125 - C250

Load class EN 1433 Standard	A15	B125	C250	D400	E600	F900
Type of concrete EN 206-1 Standard	HM-25 (X0)	HM-25 (X0)	HM-25 (X0)			
Minimum distances (mm)	X	100	100	150		
	Y	above the arcs*				
	Z	100	100	150		

\* In case of an incorrect compaction of the soil, the concrete embracement must be made up to the pavement level.

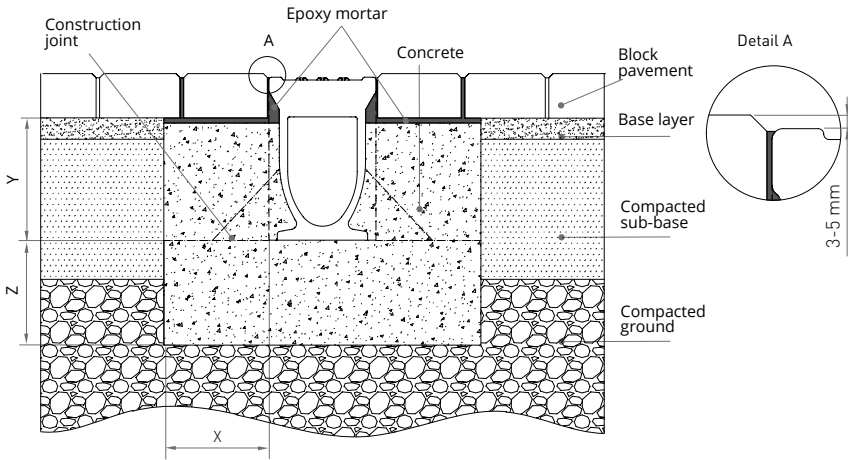

### D400

Load class EN 1433 Standard	A15	B125	C250	D400	E600	F900
Type of concrete EN 206-1 Standard				HM-25 (X0)		
Minimum distances (mm)	X			150		
	Y			up to the pavement level		
	Z			150		

## KVFDH | KVFD ASPHALT

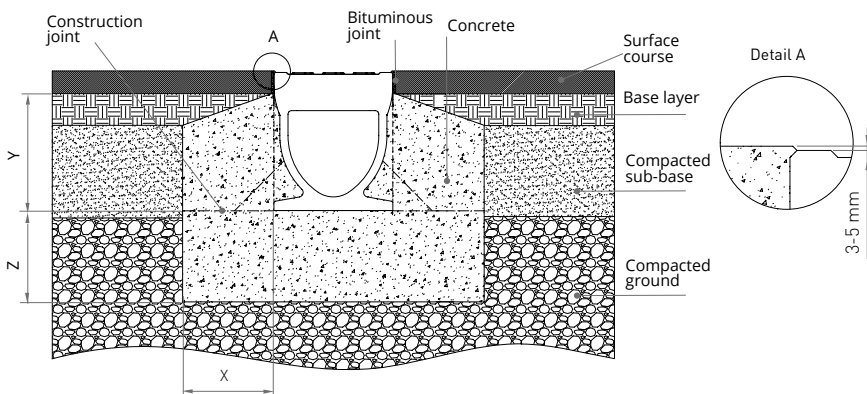

### A15 - B125 - C250 - D400 Longitudinal to the traffic direction

Load class EN 1433 Standard	A15	B125	C250	D400	E600	F900
Type of concrete EN 206-1 Standard	HM-25 (X0)	HM-25 (X0)	HM-25 (X0)	HM-25 (X0)		
Minimum distances (mm)	X	100	100	150	150	
	Y	above the arcs*				
	Z	100	100	150	150	

Installation minimal conditions. For more details, see installation instructions.

It is the customer's responsibility to make sure that installation instructions are compatible with the type of soil.

**KVFDH | KVFD ASPHALT**

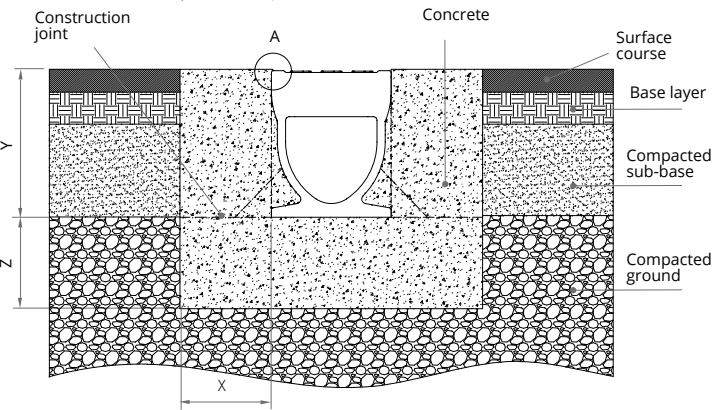
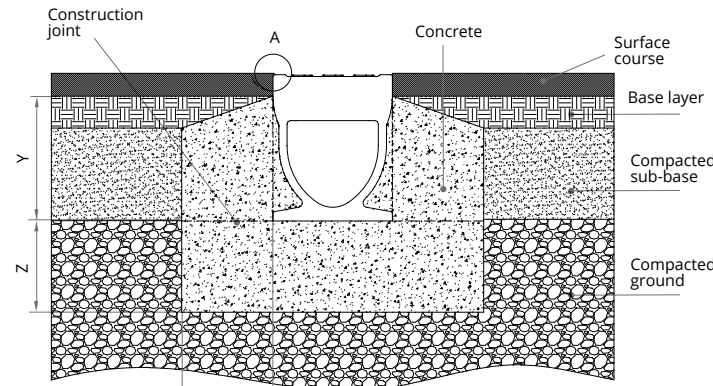

**A15 - B125 - C250**  
Transversal to the traffic direction

Load class EN 1433 Standard	A15	B125	C250	D400	E600	F900
Type of concrete EN 206-1 Standard	HM-25 (X0)	HM-25 (X0)	HM-25 (X0)			
Minimum distances (mm)	X	100	100	150		
	Y	above the arcs*				
	Z	100	100	150		

\* In case of an incorrect compactation of the soil, the concrete embracement must be made up to the pavement level.

**D400**  
Transversal to the traffic direction

Load class EN 1433 Standard	A15	B125	C250	D400	E600	F900
Type of concrete EN 206-1 Standard				HM-25 (X0)		
Minimum distances (mm)	X			200		
	Y			channel height + grid + 3-5 mm		
	Z			200		

**KVFDH | KVFD CONCRETE**

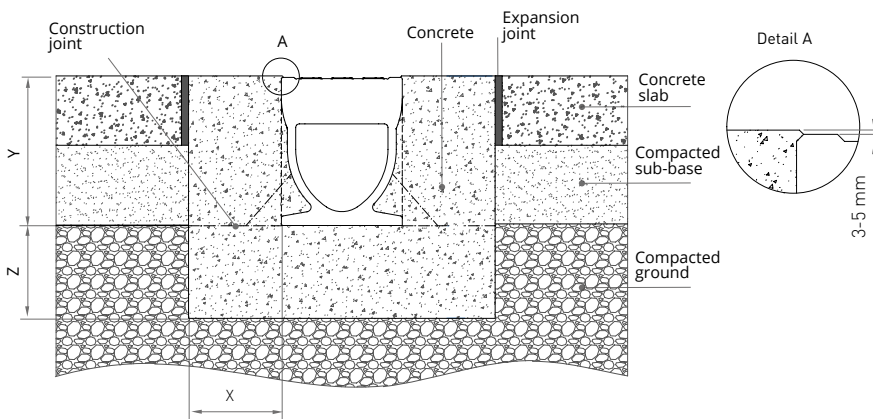

**A15 - B125 - C250 - D400**  
Longitudinal to the traffic direction

Load class EN 1433 Standard	A15	B125	C250	D400	E600	F900
Type of concrete EN 206-1 Standard	HM-25 (X0)	HM-25 (X0)	HM-25 (X0)	HM-25 (X0)		
Minimum distances (mm)	X	100	100	150	150	
	Y	channel height + grid + 3-5 mm				
	Z	100	100	150	150	

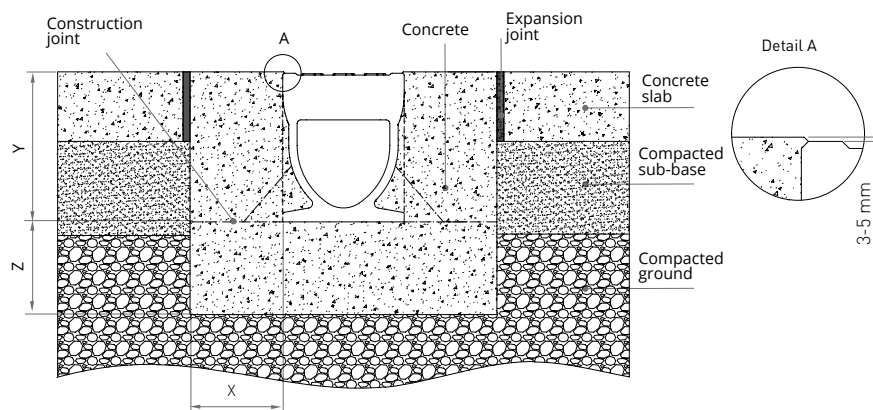

**A15 - B125 - C250 - D400**  
Transversal to the traffic direction

Load class EN 1433 Standard	A15	B125	C250	D400	E600	F900
Type of concrete EN 206-1 Standard	HM-25 (X0)	HM-25 (X0)	HM-25 (X0)	HM-25 (X0)		
Minimum distances (mm)	X	100	100	150	200	
	Y	channel height + grid + 3-5 mm				
	Z	100	100	150	200	

Installation minimal conditions. For more details, see installation instructions. It is the customer's responsibility to make sure that installation instructions are compatible with the type of soil.



KVE | KVF **ASPHALT**

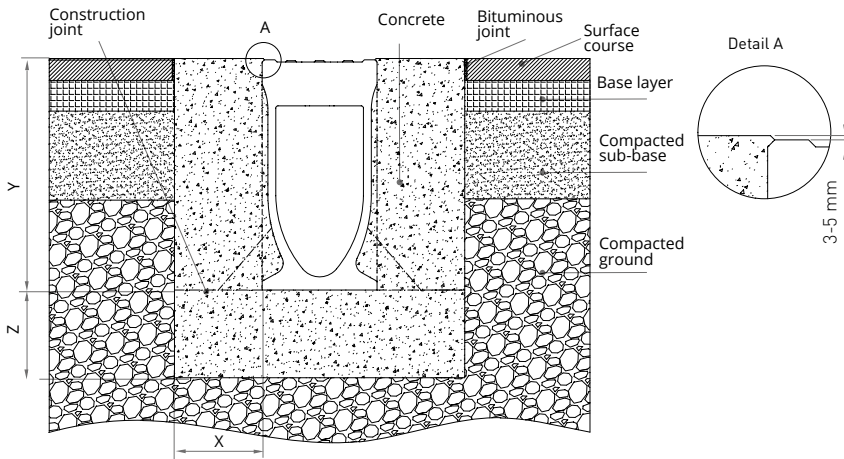

**D400 - E600 - F900**  
Longitudinal to the traffic direction

Load class EN 1433 Standard	A15	B125	C250	D400	E600	F900*
Type of concrete EN 206-1 Standard				HM-25 (X0)	HM-25 (X0)	HM-25 (X0)
Minimum distances (mm)	X			150	200	200
	Y			channel height + grid + 3-5 mm		
	Z			150	200	200

\*Complies load class without reinforcing wire mesh.

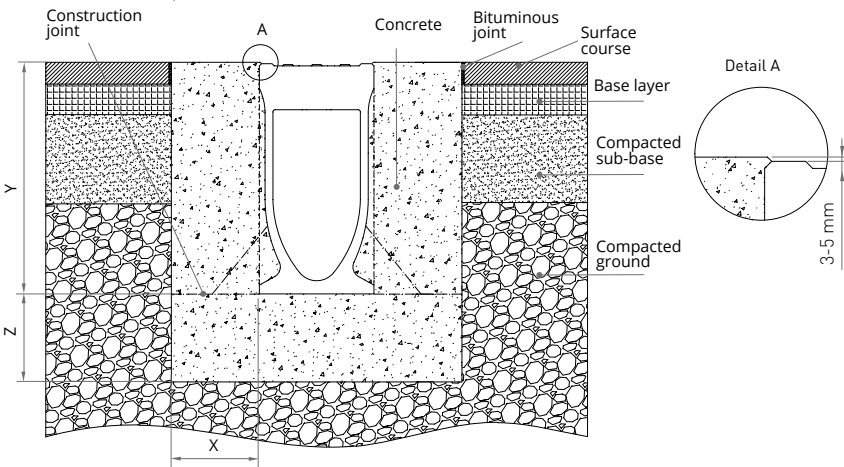

**D400 - E600 - F900**  
Transversal to the traffic direction

Load class EN 1433 Standard	A15	B125	C250	D400	E600	F900
Type of concrete EN 206-1 Standard				HM-25 (X0)	HM-25 (X0)	HM-25 (X0)
Minimum distances (mm)	X			200	200	consult
	Y			channel height + grid + 3-5 mm		
	Z			200	200	

KVE | KVF **CONCRETE**

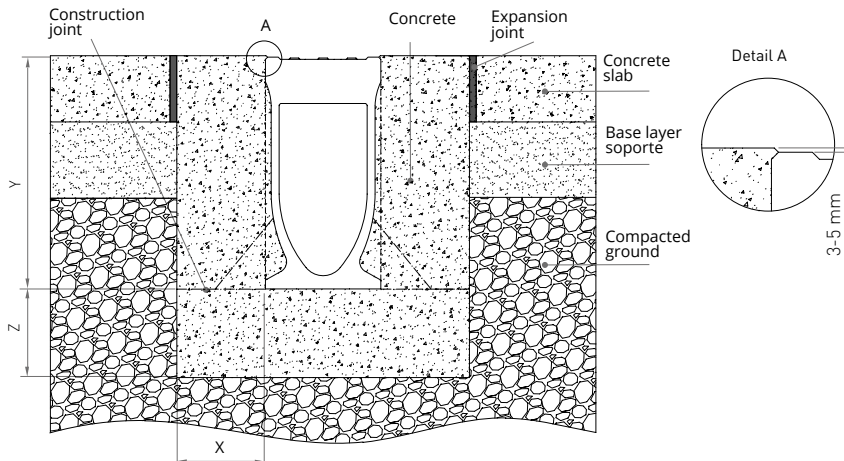

**D400 - E600 - F900**  
Longitudinal to the traffic direction

Load class EN 1433 Standard	A15	B125	C250	D400	E600	F900*
Type of concrete EN 206-1 Standard				HM-25 (X0)	HM-25 (X0)	HM-25 (X0)
Minimum distances (mm)	X			150	200	200
	Y			channel height + grid + 3-5 mm		
	Z			150	200	200

\*Complies load class without reinforcing wire mesh.

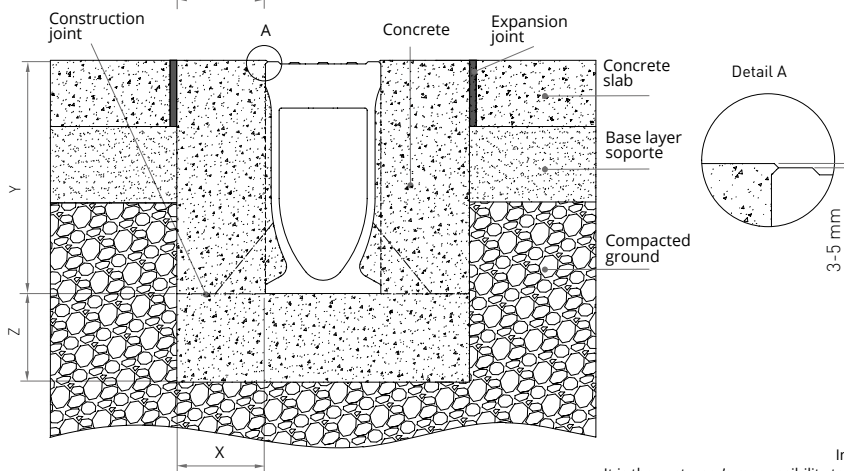

**D400 - E600 - F900**  
Transversal to the traffic direction

Load class EN 1433 Standard	A15	B125	C250	D400	E600	F900
Type of concrete EN 206-1 Standard				HM-25 (X0)	HM-25 (X0)	HM-25 (X0)
Minimum distances (mm)	X			200	200	consult
	Y			channel height + grid + 3-5 mm		
	Z			200	200	

Installation minimal conditions. For more details, see installation instructions.

It is the customer's responsibility to make sure that installation instructions are compatible with the type of soil.

# UNIQUE DETAILS

## INSTALLATION BESIDE KERB

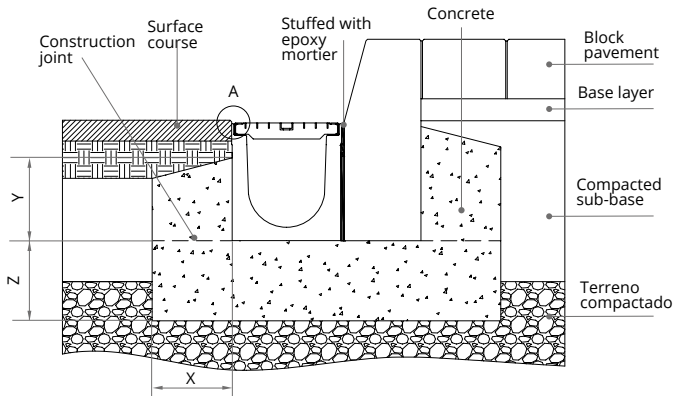

### ASPHALT

Load class EN 1433 Standard	A15	B125	C250	D400	E600	F900
Type of concrete EN 206-1 Standard	HM-25 (X0)	HM-25 (X0)	HM-25 (X0)			
Minimum distances (mm)	X	100	100	150		
	Y	above the arcs*				
	Z	100	100	150		

\* In case of an incorrect compaction of the soil, the concrete embayment must be made up to the pavement level.

## INSTALLATION ONTO A FLOOR FRAME

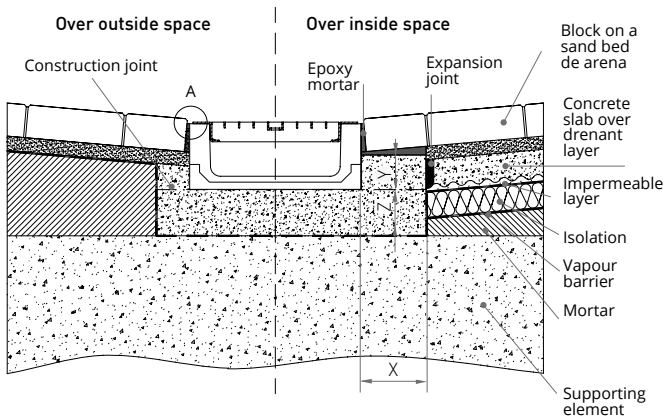

### PAVER

Load class EN 1433 Standard	A15	B125	C250	D400	E600	F900
Type of concrete EN 206-1 Standard	HM-25 (X0)	HM-25 (X0)	HM-25 (X0)			
Minimum distances (mm)	X	50	50	100		
	Y	up to the pavement level				
	Z	50	50	100		

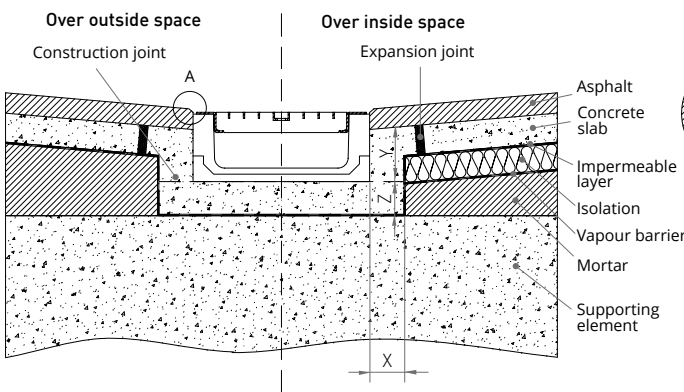

### ASPHALT

Load class EN 1433 Standard	A15	B125	C250	D400	E600	F900
Type of concrete EN 206-1 Standard	HM-25 (X0)	HM-25 (X0)	HM-25 (X0)			
Minimum distances (mm)	X	50	50	100		
	Y	up to the pavement level				
	Z	50	50	100		

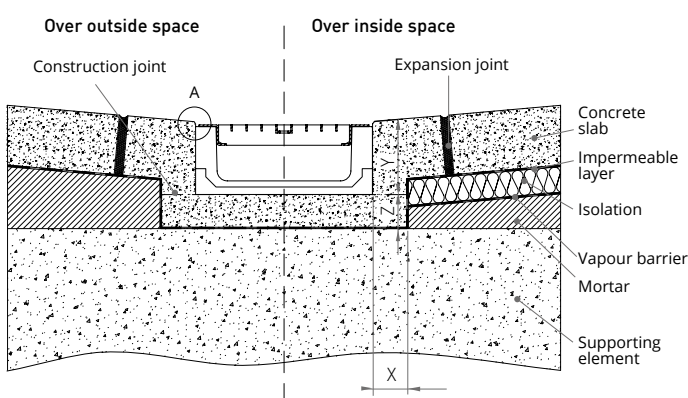

### CONCRETE

Load class EN 1433 Standard	A15	B125	C250	D400	E600	F900
Type of concrete EN 206-1 Standard	HM-25 (X0)	HM-25 (X0)	HM-25 (X0)			
Minimum distances (mm)	X	50	50	100		
	Y	channel height + grid + 3-5 mm				
	Z	50	50	100		

Installation minimal conditions. For more details, see installation instructions. It is the customer's responsibility to make sure that installation instructions are compatible with the type of soil.

# GENERAL CONDITIONS OF SALE

## 1. ORDERS

- 1.1. To avoid possible errors, orders must be sent signed and stamped to our sales technicians or our customer service department (SAC) by fax or email.
- 1.2. In the case of orders that include a special piece or custom drawing, they must be signed and stamped along with the other required information.
- 1.3. Ulma is not responsible for the choice of models and/or materials that are not suitable for the use or load indicated in our recommendations, which are included in our catalogue and on our website ([www.ulmaarchitectural.com](http://www.ulmaarchitectural.com)).

## 2. PRICES

- 2.1. The validity of the offer is indicated in the small print on the offer.
- 2.2. All prices are subject to the relevant VAT or tax.
- 2.3. ULMA may modify the prices without prior notice, and this document is a brochure with general information and in no case does it act as a contractual document.

## 3. ASSEMBLY

- 3.1. ULMA is not responsible for any material assembled without following the manufacturer's installation instructions. These are available on our website: [www.ulmaarchitectural.com](http://www.ulmaarchitectural.com).
- 3.2. For any technical information you can consult our technical department

## 4. SHIPMENTS

- 4.1. All freight costs shall be indicated in the offers and orders.
- 4.2. Any claim or incident must be notified to the corresponding commercial technician or to our customer service department within a maximum period of 72 HOURS, indicating the delivery note number and providing photographs demonstrating the reason for the incident.
- 4.3. Any claim or incident due to BREAKAGE of the material on receipt of the material MUST BE INDICATED ON THE CARRIER'S DELIVERY NOTE.
- 4.4. The material will be delivered on a lorry.
- 4.5. The unloading and means of unloading are at the customer's expense.
- 4.6. No penalties shall be admitted for delays in the supplies, these periods are approximate and shall be indicated in the offers and orders.

## 5. PAYMENT TERMS

- 5.1. The terms of payment shall be agreed by both parties and shall be indicated in each offer and in each order.
- 5.2. For credit operations, and provided it is authorised by ULMA's credit department, the maximum payment period shall not be greater than that indicated in Law 15/2010, of 5 July, published in Official State Gazette 10708 of 7 July. INSOLVENCY LAW
- 5.3. Repeated failure to meet payment deadlines shall result in the reduction or cancellation of the line of credit.
- 5.4. In the event of non-payment, ULMA reserves the right to process the payment collection through an independent company. As a first step, the supply of material for this customer shall be cut.
- 5.5. For new customers and individuals, payment shall be made in advance.
- 5.6. Withholding due to guarantee shall not be allowed.
- 5.7. No charges shall be accepted for handling payment documents.

## 6. RETURNS

- 6.1. ULMA Hormigón Polímero does not accept returns of material as indicated in all written offers.

## 7. CONTRACTS

- 7.1. No other type of contract dated after this agreement shall be accepted, nor shall any additional clauses that contravene those set out in this document.
- 7.2. If the customer is required to enter a contract, the contract must be entered before the order is processed, ULMA will not process any order until the contract is in its possession, duly completed and signed by both parties.

## 8. JURISDICTION

- 8.1. Any lawsuit arising from the commercial relationship shall be resolved in the courts determined by ULMA.
- 8.2. The technical information contained in this document is the information in force at date of printing, therefore, in order to update this information, we recommend you visit our website [ulmaarchitectural.com](http://ulmaarchitectural.com).
- 8.3. ULMA reserves the right to modify the specifications of any of its products without prior notice.



DRAINAGE AND ARCHITECTURE

*- for people by people -*

**ULMA** ARCHITECTURAL SOLUTIONS

[ulmaarchitectural.com](http://ulmaarchitectural.com)  
B° Zubillaga, 89 - Apdo. 20,  
20560 Oñati (Gipuzkoa) Spain  
Tel.: 00 34 943 78 06 00  
[info@ulmaarchitectural.com](mailto:info@ulmaarchitectural.com)